

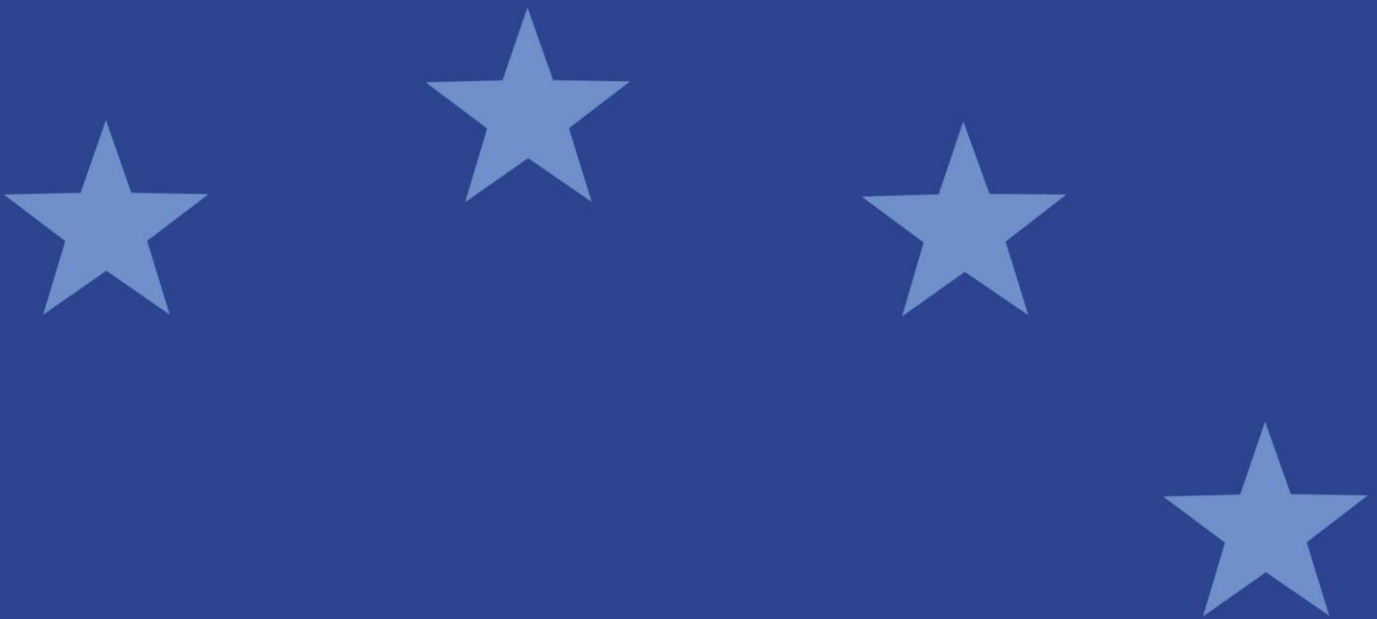

European Securities and
Markets Authority

Reply form for the ESMA MiFID II/MiFIR Discussion Paper





European Securities and
Markets Authority

Date: 22 May 2014



Responding to this paper

The European Securities and Markets Authority (ESMA) invites responses to the specific questions listed in the ESMA MiFID II/MiFIR Discussion Paper, published on the ESMA website ([here](#)).

Instructions

Please note that, in order to facilitate the analysis of the large number of responses expected, you are requested to use this file to send your response to ESMA so as to allow us to process it properly. Therefore, please follow the instructions described below:

- i. use this form and send your responses in Word format;
- ii. do not remove the tags of type <ESMA_QUESTION_1> - i.e. the response to one question has to be framed by the 2 tags corresponding to the question; and
- iii. if you do not have a response to a question, do not delete it and leave the text “TYPE YOUR TEXT HERE” between the tags.

Responses are most helpful:

- if they respond to the question stated;
- contain a clear rationale, including on any related costs and benefits; and
- describe any alternatives that ESMA should consider

Given the breadth of issues covered, ESMA expects and encourages respondents to specially answer those questions relevant to their business, interest and experience.

To help you navigate this document more easily, bookmarks are available in “Navigation Pane” for Word 2010 and in “Document Map” for Word 2007.

Responses must reach us by **1 August 2014**.

All contributions should be submitted online at www.esma.europa.eu under the heading ‘Your input/Consultations’.

Publication of responses

All contributions received will be published following the end of the consultation period, unless otherwise requested. **Please clearly indicate by ticking the appropriate checkbox in the website submission form if you do not wish your contribution to be publicly disclosed. A standard confidentiality statement in an email message will not be treated as a request for non-disclosure.** Note also that a confidential response may be requested from us in accordance with ESMA’s rules on access to documents. We may consult you if we receive such a request. Any decision we make is reviewable by ESMA’s Board of Appeal and the European Ombudsman.

Data protection

Information on data protection can be found at www.esma.europa.eu under the heading ‘Disclaimer’.



1. Overview

2. Investor protection

2.1. Authorisation of investment firms

Q1: Do you agree that the existing work/standards set out in points Error! Reference source not found. and Error! Reference source not found. Error! Reference source not found. provide a valid basis on which to develop implementing measures in respect of the authorisation of investment firms?

<ESMA_QUESTION_1>

AFME Response

In principle, we agree with ESMA that the implementing measures should be based on the existing standards. However, we would urge ESMA to use the opportunity to rationalise and streamline the information requirements wherever possible to ensure that regulators receive the information they really need and firms are not unduly burdened with onerous information requirements. This will result in smoother and speedier flows of information between both firms and competent authorities and allow firms to provide cross border services more quickly, which will ultimately benefit clients.

<ESMA_QUESTION_1>

Q2: What areas of these existing standards do you consider require adjustment, and in what way should they be adjusted?

<ESMA_QUESTION_2>

AFME Response

See our comments to Question 1.

<ESMA_QUESTION_2>

Q3: Do you consider that the list of information set out in point Error! Reference source not found. should be provided to Home State NCAs? If not, what other information should ESMA consider?

<ESMA_QUESTION_3>

AFME Response

The information appears broadly relevant (but see our comments in Q1); however, we note that the information requirements regarding the management body are very detailed and may on occasions be difficult to establish in all instances, e.g. management may have not kept detailed records of the precise number of employees reporting into them over the last ten years. A five-year period may be more appropriate. The information requirements e.g. regarding the financial and non-financial interests of close associates of members of the management body including children or parents are very intrusive and may pose questions over data privacy issues in certain jurisdictions.

With respect to point 6(f) under “Information on the capital”, rather than requiring evidence that “no money laundering or terrorist financing is attempted” it would be more effective to express this requirement in terms of controlling and managing the risk that the relevant firm will be used by others for money laundering or terrorist financing. In addition, further clarity is required with respect to the types of documentary support required to ensure that the anti-money laundering risk is reduced.

With respect to “Information on the organisation”, the requirement to provide a programme of initial operations for the next three is potentially challenging and we believe a shorter period would be more appropriate. For example, the UK Financial Conduct Authority forms have focused on the initial twelve months, whilst three years is more consistent with requirements on existing firms being acquired.

Alternatively, the requirement could be amended such that the programme of initial operations for the next three years would only be required so far as the firm has developed such plans, but, at a minimum, a programme for the first twelve months would be required.

Furthermore, a start-up likely would find it difficult to provide a definitive and detailed programme for its regulated and unregulated activities. In addition, point 9(iii) also requires significant amounts of information about the identity of planned marketers, financial advisors etc. This requirement should be adjusted by referring to the identity and address details of the marketers etc. or, if not yet identified, the expected geographical localisation of proposed appointees.

<ESMA_QUESTION_3>

Q4: Are there any other elements which may help to assess whether the main activities of an applicant investment firm is not in the territory where the application is made?

<ESMA_QUESTION_4>

AFME Response

Yes. The “elements” identified for helping to assess, whether the main activities of the applicant investment firm are not in the territory where the application is made, are already very comprehensive. However, we would suggest that the relevant information provided under the programme of operations (referred to in MiFID 2 Article 7(2)), may, at the option of the applicant investment firm, also include a description of its rationale in having opted for the particular regulatory system of a member state. Members believe that this will give the firm an opportunity to explain its objectives rather than setting forth facts concerning its activities which could be misinterpreted without further explanation.

Furthermore, MiFIR Article 46.7 states “*ESMA shall develop draft regulatory technical standards to specify the information that the applicant third-country firm shall provide to ESMA in its application for registration in accordance with paragraph 4 and the format of information to be provided in accordance with paragraph 5*”. However, neither the Consultation Paper nor the Discussion Paper makes any reference to these draft RTS. We would be grateful if ESMA could confirm when these RTS will be issued for consultation although we understand this is likely to be in the Q4 Consultation Paper.

<ESMA_QUESTION_4>

Q5: How much would one-off costs incurred during the authorisation process increase, compared to current practices, in order to meet the requirements suggested in this section?

<ESMA_QUESTION_5>

AFME Response



As a trade association, AFME is not placed to comment on this question.

<ESMA_QUESTION_5>

Q6: Are there any particular items of information suggested above that would take significant time or cost to produce and if so, do you have alternative suggestions that would reduce the time/cost for firms yet provide the same assurance to NCAs?

<ESMA_QUESTION_6>

AFME Response

See our answers above.

<ESMA_QUESTION_6>

2.2. Freedom to provide investment services and activities / Establishment of a branch

Q7: Do you agree that development of technical standards required under Articles 34 and 35 of MiFID II should be based on the existing standards and forms contained in the CESR Protocol on MiFID Notifications (CESR/07-317c)? If not, what are the specific areas in the existing CESR standards requiring review and adjustment?

<ESMA_QUESTION_7>

AFME Response

Yes, we agree that the requirements should be based on existing standards as far as possible. However, it will be important to ensure that the new RTS content which is based on historical standards and protocols is amended to reflect MiFID 2 including e.g. the possibility that member states may require third country firms to establish branches when providing services for retail clients or elective professionals.

Given the number of provisions in MiFID/MiFIR which will be impacted by equivalence determinations, firms will also need clarity (from ESMA/and or the Commission) regarding the third country equivalence test and details of how that will operate. Whilst we acknowledge that the final equivalence decision are for the Commission, it is important ESMA will support the Commission so that these are undertaken in a consistent and transparent way.

We also need confirmation on what further consultation on third country issues will be undertaken by ESMA including those under MiFIR Article 46(7), although we understand that this is likely to be in the Consultation paper due in Q4.

<ESMA_QUESTION_7>

2.3. Best execution - publication of data related to the quality of execution by trading venues for each financial instrument traded

Q8: Do you agree data should be provided by all the execution venues as set out in footnote 24? If not, please state why not.

<ESMA_QUESTION_8>



AFME Response

No. AFME does not agree with ESMA's interpretation of "Execution Venues" and that this would include the infrastructures known as SIs as well as market makers. Although both SIs and Market Makers have definitions in the final texts of MiFID/R, it is important to note the distinction between these very different microstructures. It is not practicable for a market maker or an SI to have the same reporting requirement as a trading venue.

Based on the above AFME does not agree that [an investment firm acting as] a "market maker" constitutes an "execution venue". We do not therefore think it is appropriate to apply the execution quality reporting obligation to "market makers" given the latter's provision of liquidity to other market counterparties and that all execution data will be captured and published by the RM or MTF on which the market maker is active.

In addition there are fundamental differences between the execution venues set out at footnote 24, and AFME believes that it would be erroneous not to have regard to these differences in the setting and publication of execution quality data. This is especially the case for the S.I in contrast to RMs, MTFs and OTFs. RMs, MTFs and OTFs are multilateral, non-discretionary venues that exist on separate and distinct technology infrastructure. The SI is a bilateral, discretionary trading process and does not have a platform.

Furthermore, best Execution obligations are already covered by the best execution requirements of the investment firm. An SI will always be operated by an investment firm. Data would therefore need to be separated by order type, trading period etc.

We agree data should be provided by RMs, MTFs and OTFs. A systematic internaliser ("S.I.") operates in a different manner to RMs, MTFs and OTFs. Where an investment firm acts as an S.I., it deals on its own account in executing its clients' orders. As such, it would be inappropriate [and potentially misleading] for S.I. execution details to be benchmarked by market participants against the execution data provided by RMs and MTFs. An investment firm acting in its capacity as an S.I. is operating in a closed environment and providing a service on a bilateral basis to its clients only. These key differences should be taken into account in the setting and publication of execution data for S.I.s.

<ESMA_QUESTION_8>

Q9: If you think that the different types of venues should not publish exactly the same data, please specify how the data should be adapted in each case, and the reasons for each adjustment.

<ESMA_QUESTION_9>

AFME Response

See response to question 8 above.

The fundamental difference between RMs/MTFs SIs should be reflected by different publication requirements for SIs as well as clear separation of data relating to SIs.

<ESMA_QUESTION_9>

Q10: Should the data publication obligation apply to every financial instrument traded on the execution venue? Alternatively, should there be a minimum threshold of activity and, if so, how should it be defined (for example, frequency of trades, number of trades, turnover etc.)?

<ESMA_QUESTION_10>

AFME Response

The obligation should not apply to every financial instrument traded on the venue. For example if an instrument is illiquid then the data cannot be considered representative of its behaviour and any report provided could also be misleading. This is particularly the case for fixed income and must be considered when determining any form of thresholds as proposed. The different fixed income products are all unique and so AFME would recommend determining any thresholds in line with the AFME Post Trade Transparency and liquidity calibration. Whilst being sensitive to bespoke markets, thresholds to publish data should be set at sufficiently high levels such that market participants are not forced to review execution policies simply on the new entry of a venue that may not yet have established any reasonable liquidity

<ESMA_QUESTION_10>

Q11: How often should all execution data be published by trading venues? Is the minimum requirement specified in MiFID II sufficient, or should this frequency be increased? Is it reasonable or beneficial to require publication on a monthly basis and is it possible to reliably estimate the marginal cost of increased frequency?

<ESMA_QUESTION_11>

AFME Response

Execution quality data should be published on an annual basis; it would not be reasonable to require publication more frequently.

<ESMA_QUESTION_11>

Q12: Please provide an estimate of the cost of the necessary IT development for the production and the publication of such reporting.

<ESMA_QUESTION_12>

AFME Response

An estimation of costs of production and publication would be highly dependent on the data requirements and it would need to take into account how the data is to be defined, and what format data will have to take. The more granular the data, the greater the technology build, and implementation would have to allow necessary and robust testing of the technology and the data itself. Costs likely would be front loaded.

<ESMA_QUESTION_12>

Q13: Do you agree that trading venues should publish the data relating to the quality of execution with regard to a uniform reference period, with a minimum of specific reporting details and in a compatible format of data based on a homogeneous calculation method? If not, please state why.

<ESMA_QUESTION_13>

AFME Response

No. AFME members would like to ask for clarity in relation to the way in which ‘quality of execution’ would be defined and what this would be in reference to. As previously mentioned each financial instrument has very different characteristics and therefore a ‘one size fits all’ approach for financial instruments should not become standard.

AFME believe that for data to be meaningful to market participants, it should be published by reference to a uniform period, with minimum specific reporting details and in a format based on a homogenous calculation method.



<ESMA_QUESTION_13>

Q14: Is the volume of orders received and executed a good indicator for investment firms to compare execution venues? Would the VBBO in a single stock published at the same time also be a good indicator by facilitating the creation of a periodic European price benchmark? Are there other indicators to be considered?

<ESMA_QUESTION_14>

AFME Response

Market share is a good indicator to compare execution venues for access to liquidity. However, AFME prefers a volume weighted, or simple EBBO as the appropriate price benchmark. AFME considers that publishing execution performance with regard to an EBBO is essential to the integrity of the publishing requirement. Without this, investors can make little meaningful deductions as to whether pricing considerations are well served by any stated execution policy. Despite the absence of a consolidated, pre-trade tape, AFME notes that there are firms that can provide such data cost-effectively. AFME would suggest that a simple approach to EBBO calculation would include the primary market of listing together with any MTF with 5% or more of pan-EU market share.

It is felt, particularly from a fixed income perspective, that although volume is a good indicator of market share, market share is not necessarily an indicator of best execution. Market share may assist with assessment of likelihood to execute, but not necessarily for price, cost or speed. Once again AFME members would like to note that financial fixed income instruments should be looked at based on their individual characteristics.

<ESMA_QUESTION_14>

Q15: The venue execution quality reporting obligation is intended to apply to all MiFID instruments. Is this feasible and what differences in approach will be required for different instrument types?

<ESMA_QUESTION_15>

AFME Response

From a Fixed Income perspective AFME would like to stress the importance of liquidity and its calibration when determining 'execution quality'. We believe that any reporting obligation for fixed income instruments should include liquidity considerations.

<ESMA_QUESTION_15>

Q16: Do you consider that this requirement will generate any additional cost? If yes, could you specify in which areas and provide an estimation of these costs?

<ESMA_QUESTION_16>

AFME Response

As noted in the response to Question 12, an estimate of costs of production and publication would be highly dependent on the data requirements and would need to take into account how the data is to be defined and, what format data will have to take. The more granular the data, the greater the technology build, and implementation would have to allow necessary and robust testing of the technology and the data itself. Costs likely would be front loaded.

<ESMA_QUESTION_16>

Q17: If available liquidity and execution quality are a function of order size, is it appropriate to split trades into ranges so that they are comparable? How should they be defined (for example, as a percentage of the average trading size of the financial instrument on the execution venue; fixed ranges by volume or value; or in another manner)?

<ESMA_QUESTION_17>

AFME Response

Bands should be used if a simple EBBO is used as the benchmark.

Currently there is not a clear cut distinction between different FI instruments (not even for liquidity purposes which is being worked on in the transparency context). It would therefore be challenging to compare instruments on a like for like basis as well as then putting this into the context of the different 'execution venues' which currently include SIs as well as Market Makers. The 'likelihood of execution' is too complex to determine based on individual order size. AFME members would encourage this work to be aligned with the liquidity calibration work being undertaken.

<ESMA_QUESTION_17>

Q18: Do you agree that a benchmark price is needed to evaluate execution quality? Would a depth-weighted benchmark that relates in size to the executed order be appropriate or, if not, could you provide alternative suggestions together with justification?

<ESMA_QUESTION_18>

AFME Response

No. AFME agrees that a benchmark price is required and would support the publication of the volume weighted EBBO.

From a fixed income perspective as noted above, AFME believes that this question is liquidity led. If a bond is not liquid then there would be no index or value which could be used to determine a benchmark price. We would encourage liquidity to be used to evaluate execution quality as a benchmark price would not be a true reflection of bond market activity at any given time. A benchmark price to evaluate 'execution quality' would not be feasible for fixed income instruments.

<ESMA_QUESTION_18>

Q19: What kind of cost should be reported (e.g. regulatory levies, taxes, mandatory clearing fees) and how should this data be presented to enable recipients to assess the total consideration of transactions?

<ESMA_QUESTION_19>

AFME Response

Costs borne to transact on a venue are not comparable across venues particularly in the case of an SI where the cost of this process would be difficult to extract from the overall cost infrastructure at the investment firm.

There is also a need to take into consideration order type, trading period (i.e. Auction, Continuous Trading, pre-trade transparency (dark/lit order book) etc.

In Fixed Income there is no visibility on the execution side of all the post trade fees. AFME members would like clarity as to whether this would require investment firms to report fees to venues. Within the Fixed Income market there is not that much clearing but rather a core broker



market which is cleared and therefore only the execution fees of the venue would be relevant to be reported. We would ask for further clarification as to what costs may be included in this reporting. Costs borne to transact on venue are not comparable across venues particularly in the case of an SI where the cost of this process would be difficult to extract from the overall cost infrastructure at the investment firm.

<ESMA_QUESTION_19>

Q20: What would be the most appropriate way to measure the likelihood of execution in order to get useful data? Would it be a good indicator for likelihood of execution to measure the percentage of orders not executed at the end of the applicable trading period (for example the end of each trading day)? Should the modification of an order be taken into consideration?

<ESMA_QUESTION_20>

AFME Response

AFME believes the most appropriate way to measure likelihood of execution is by market share and order type (e.g. limit orders, Request for Quotes etc). It would also depend on which financial instrument is being traded for example there should be a differentiation between rates trading and corporate bond trading as the difference in liquidity in these instruments will have an effect as to the likelihood of execution. AFME notes that ESMA has identified the question as to how venues will be differentiated based on the liquidity they may have in certain instruments (e.g. a smaller venue may not have as much liquidity in a product as a larger venue) and we would encourage this methodology to remain when ascertaining the indicators for what is to establish 'likelihood of execution'.

<ESMA_QUESTION_20>

Q21: What would be the most appropriate way to measure the speed of execution in order to get useful data?

<ESMA_QUESTION_21>

AFME Response

AFME would highlight again the differences in microstructure. While venues such as RMs are based on a technology platform, an SI is a business process and is not a venue that has infrastructure and speed here would be very difficult to measure and not comparable

Most of the trading venues already have statistics to indicate speed of execution which would normally provide the average time of execution. However this will also be dependent and different for the different order types placed. It would be beneficial to differentiate between the various financial instruments as well as to consider liquidity when determining the speed of execution and how to measure it.

<ESMA_QUESTION_21>

Q22: Are there other criteria (qualitative or quantitative) that are particularly relevant (e.g. market structures providing for a guarantee of settlement of the trades vs OTC deals; robustness of the market infrastructure due to the existence of circuit breakers)?

<ESMA_QUESTION_22>

AFME Response

Availability of infrastructure, and reliability / outages of platform should be reported.



From a fixed income perspective we believe that order type, liquidity, size of a particular instrument should be considered as other relevant criteria. In addition, any non standard settlement orders should be examined separately.

<ESMA_QUESTION_22>

Q23: Is data on orders cancelled useful and if so, on what time basis should it be computed (e.g. within a single trading day)?

<ESMA_QUESTION_23>

AFME Response

Cancellation of orders is not an action that is entirely under a venue's control and AFME believes it would be more useful to provide data on actual executions. Any data on orders cancelled will only be meaningful where expressed as a ratio. Moreover numbers may not be comparable. Depending on the market microstructure there may be cancellations followed by replacements on one platform that show up as edits on another platform. Therefore, similar activity will result in different numbers.

AFME believe that data on trades cancelled would be more useful than data on orders cancelled. The importance of noting data on orders cancels is applicable to limit orders however at the moment the market would not necessarily benefit from data on cancelled orders.

<ESMA_QUESTION_23>

Q24: Are there any adjustments that need to be made to the above execution quality metrics to accommodate different market microstructures?

<ESMA_QUESTION_24>

AFME Response

Yes. The SI represents the market microstructure most different to the other trading venues and adjustments here need to be made with regard to the factors of speed, costs and 'likelihood of execution' (please note our request for further information as to the meaning and context of this phrase). More generally execution quality will vary greatly over the spectrum of most liquid to least liquid instruments.

We would recommend that ESMA also consider any non standard settlements as these would need to be taken into consideration when conducting market data. The SI represents the market microstructure most different to the other trading venues and adjustments here need to be made with regard to the factors of speed, costs and 'likelihood of execution'. More generally execution quality will vary greatly over the spectrum of most liquid to least liquid instruments.

<ESMA_QUESTION_24>

Q25: What additional measures are required to define or capture the above data and relevant additional information (e.g. depth weighted spreads, book depths, or others) How should the data be presented: on an average basis such as daily, weekly or monthly for each financial instrument (or on more than one basis)? Do you think that the metrics captured in the Annex to this chapter are relevant to European markets trading in the full range of MiFID instruments? What alternative could you propose?

<ESMA_QUESTION_25>

TYPE YOUR TEXT HERE

<ESMA_QUESTION_25>

Q26: Please provide an estimate of the costs of production and publication of all of the above data and, the IT developments required? How could these costs be minimised?

<ESMA_QUESTION_26>

AFME Response

Estimation of costs of production and publication is highly dependent on the data requirements. It will need to take into account how the data is to be defined and what format data will have to take. The more granular the data, the greater the technology build, and implementation will have to allow necessary and robust testing of the technology and the data itself. Costs are likely to be front loaded.

<ESMA_QUESTION_26>

Q27: Would increasing the frequency of venue execution quality data generate additional costs for you? Would these costs arise as a result of an increase of the frequency of the review, or because this review will require additional training for your staff in order to be able to analyse and take into account these data? Please provide an estimate of these costs.

<ESMA_QUESTION_27>

AFME Response

Increased frequency of data will inevitably increase review related costs. As per the answer to question 26 above it is not possible to assess this cost without first knowing the data requirements.

Any operational system changes/builds will require funding. AFME members would like to note that although the majority of requirements are already in place at member firms, any changes will incur additional costs which would have to be taken into account. Increased frequency of data will inevitably increase review related costs.

<ESMA_QUESTION_27>

Q28: Do you agree that investment firms should take the publication of the data envisaged in this Discussion Paper into consideration, in order to determine whether they represent a “material change”?

<ESMA_QUESTION_28>

AFME Response

No. The publication of the data envisaged in this Discussion Paper is one factor that investment firms take into consideration, in order to determine whether they represent a “material change” alongside other data points available to the investment firm in question.

We would like to ask for further details as to what would constitute a ‘material change’. Overall we believe it should be taken into consideration alongside data points. The publication of the data envisaged in this Discussion Paper is one factor that investment firms take into consideration, in order to determine whether they represent a “material change” alongside other data points available.

<ESMA_QUESTION_28>

2.4. Best execution - publication of data by investment firms



Q29: Do you agree that in order to allow clients to evaluate the quality of a firm's execution, any proposed standards should oblige the firm to give an appropriate picture of the venues and the different ways they execute an order?

<ESMA_QUESTION_29>

AFME Response

No. AFME believes it is not clear as to what the parameters of an 'appropriate picture' would be.

Furthermore, clients use TCA (Transaction Cost Analysis) tools to measure execution performance of a parent order. Measurements of a child (trading venue) order should be measured in relationship to the parent order.

Although we understand that investment firms should provide information on best execution for each class of financial instruments, we would also seek further clarification as what may be interpreted from 'class of financial instrument' and whether there would be a standard for this categorisation.

<ESMA_QUESTION_29>

Q30: Do you agree that when systematic internalisers, market makers, OTC negotiation or dealing on own account represent one of the five most important ways for the firm to execute clients' orders, they should be incorporated in the reporting obligations under Article 27(6) of MiFID II?

<ESMA_QUESTION_30>

AFME Response

No. From an equities perspective AFME believes that this should be limited to data of top five venues.

From a fixed income perspective it may be complex to distinguish clearly between OTC/market making/dealing on own account/SI as some of these would overlap.

<ESMA_QUESTION_30>

Q31: Do you think that the data provided should be different in cases when the firm directly executes the orders to when the firm transmits the orders to a third-party for execution? If yes, please indicate what the differences should be, and explain why.

<ESMA_QUESTION_31>

AFME Response

AFME believes that best execution data should only be transmitted to clients by the entities directly executing orders, not least because often in the case of transmission the complete data is not available to the RTO entity.

Customarily, brokers to whom orders are transmitted (on the basis of the best selection obligations applicable to the RTO agreement with the client) will report back best execution data to the client directly by the broker. RTO entities report to clients on the implementation of the RTO mandate (best selection).

<ESMA_QUESTION_31>

Q32: Do you consider that information on both directed and non-directed orders is useful? Should the data be aggregated so that both types of order are shown together or separated? Should there be a similar approach to disclosure of information on market orders versus limit orders? Do you think that another categorisation of client orders could be useful?

<ESMA_QUESTION_32>

AFME Response

AFME questions the utility of data aggregated in this way. AFME believes the most useful data is the data which relates to those orders to which the best execution regulations apply. There currently does not seem to be a distinction between direct/non directed orders and this would not be easily applicable to all asset classes.

<ESMA_QUESTION_32>

Q33: Do you think that the reporting data should separate retail clients from other types of clients? Do you think that this data should be publicly disclosed or only provided to the NCA (e.g. when requested to assess whether there is unfair discrimination between retail clients and other categories)? Is there a more useful way to categorise clients for these purposes?

<ESMA_QUESTION_33>

AFME Response

AFME believes that data should be made available to the NCA and to clients as per the core obligation in the Level 1 text. AFME regards this data as commercially sensitive and public dissemination of this data would compromise investment firms.

<ESMA_QUESTION_33>

Q34: Do you agree that the investment firms should publish the data relating to their execution of orders with regard to a uniform reference period, with a minimum of specific reporting details and in a compatible format of data based on a homogeneous calculation method? If not, please state why.

<ESMA_QUESTION_34>

AFME Response

AFME agrees that for data to be meaningful to market participants, it should be published by reference to a uniform period, with minimum specific reporting details and in a format based on a homogenous calculation method.

<ESMA_QUESTION_34>

Q35: What would be an acceptable delay for publication to provide the clients with useful data?

<ESMA_QUESTION_35>

AFME Response

Any delay to data provision would be subject to the data that is being provided. Larger venues may publish under a shorter time frame than smaller venues. Again micro structural issues should be considered when looking at different venue types. Additionally it should be considered that as an example if material is produced on an annual basis then this data should be provided one month following this annual date to ensure consolidation is possible and to take into account the full year's worth of data.



<ESMA_QUESTION_35>

Q36: What format should the report take? Should there be any difference depending on the nature of the execution venues (MTF, OTF, Regulated Market, systematic internalisers, own account) and, if so, could you specify the precise data required for each type?

<ESMA_QUESTION_36>

AFME Response

Please refer to Questions 8 & 9. Additionally it should be recognised that nuances such as auction periods vs. continuous trading periods should be taken into account when making like for like comparisons as this would not be possible (e.g. consolidated primaries vs. MTFs).

<ESMA_QUESTION_36>

Q37: Do you agree that it is proportionate to require investment firms to publish on an annual basis a summary based on their internal execution quality monitoring of their top five execution venues in terms of trading volumes, subject to certain minimum standards?

<ESMA_QUESTION_37>

AFME Response

In line with our response question 31 above, this requirement should only apply to firms directly executing orders. AFME member would like to seek clarification as to the term 'execution quality monitoring' and what this would entail/consist of.

<ESMA_QUESTION_37>

Q38: Do you have views on how 'directed orders' covered by client specific instructions should be captured in the information on execution quality? Is it possible to disaggregate reporting for directed orders from those for which there are no specific instructions and, if so, what the most relevant criteria would be for this exercise?

<ESMA_QUESTION_38>

AFME Response

Please refer to question 32

<ESMA_QUESTION_38>

Q39: Minimum standards to ensure that the summary of the firm's internal execution quality monitoring of their top five execution venues (in terms of trading volumes) is comprehensive and contains sufficient analysis or context to allow it to be understood by market participants shall include the factors set out at paragraph 29. Do you agree with this analysis or are there any other relevant factors that should be considered as minimum standards for reporting?

<ESMA_QUESTION_39>

AFME Response

AFME agrees with the analysis at paragraph 29 provided these factors were not for external publication and were available for the NCA and clients as per comment at question 33

AFME would not encourage the external publication as this information may be commercially sensitive information. This information should be available for NCAs as well as clients.

<ESMA_QUESTION_39>

Q40: Can you recommend an alternative approach to the provision of information on execution quality obtained by investment firms, which is consistent with Article 27(6) of MiFID II and with ESMA's overall objective to ensure proportionate implementation?

<ESMA_QUESTION_40>

AFME Response

Regard should be given to the complex and sophisticated trading environment in which investment firms operate. Due to this complexity the provision of information on 'execution quality' (AFME members seek further clarification as to this term and its meaning), consistencies with Article 27 (6) are already in existence.

<ESMA_QUESTION_40>

Q41: Do you agree that ESMA should try to limit the number of definitions of classes of instruments and provide a classification that can be used for the different reports established by MiFID and MiFIR?

<ESMA_QUESTION_41>

AFME Response

No. Due to the complexities of fixed income instruments and their complex liquidity structures, AFME members would like to encourage the work of differentiating between liquid and illiquid assets wherever possible. The work being undertaken on liquidity calibration and definition would be appropriate for such a classification.

<ESMA_QUESTION_41>

Q42: If this approach is not viable how should these classes be defined? What elements should be taken into consideration for that classification? Please explain the rationale of your classification. Is there a need to delay the publication of the reporting for particular class of financial instruments? If the schedule has to be defined, what timeframe would be the most relevant?

<ESMA_QUESTION_42>

AFME Response

Please see Question 41- the recommendation to use the liquidity definition and calibration work as a means to determining different asset classes within fixed income.

<ESMA_QUESTION_42>

Q43: Is any additional data required (for instance, on number of trades or total value of orders routed)?

<ESMA_QUESTION_43>

AFME Response

AFME do not believe additional data needs to be provided.

<ESMA_QUESTION_43>

Q44: What information on conflicts of interest would be appropriate (inducements, capital links, payment for order flow, etc.)?

<ESMA_QUESTION_44>



AFME Response

It would be appropriate for investment firms to declare any interest in their top five venues. AFME believe it would be appropriate to disclose in the annual summary any material shareholdings e.g. > 5% (excluding the trading book as defined) that an investment firm holds in an execution venue.

[Information on inducements and other conflicts should be adequately addressed in other processes and procedures.]

<ESMA_QUESTION_44>

3. Transparency

3.1. Pre-trade transparency - Equities

Q45: What in your view would be the minimum content of information that would make an indication of interest actionable? Please provide arguments with your answer.

<ESMA_QUESTION_45>

AFME Response

In line with Article 2(1)(33) of MiFIR, actionable IOIs are defined as “a message... in relation to available trading interest that contains all the necessary information to agree on a trade.” ESMA’s proposal concentrates on the “necessary information”, but does not elaborate on the availability criteria in relation to “available trading interest”, although ESMA does clarify that the message has to contain “binding expression” to trade from one counterparty to the counterparty that initially sought the indication of interest to trade. We believe that the binding nature will have to be part of information content transmitted by the firm providing the indication of interest, even if this binding intention is not repeated on each and every provision of an IOI. If such readiness to accept the order is not demonstrated, then it is not clear that the IOI is in relation to “available trading interest”. If, for instance, the firm providing the quote has the ability to reject an incoming acceptance of the IOI, this should render the IOI not actionable. We would therefore propose that ESMA should define the minimum necessary information as follows:

“Minimum necessary information means price, volume, whether it is a buy or sell order, stock ticker, time-in-force, and an expression of unconditional readiness to execute if the counterparty places an order in response to the indication of interest”.

<ESMA_QUESTION_45>

Q46: Do you agree with ESMA’s opinion that Table 1 of Annex II of Regulation 1287/2006 is still valid for shares traded on regulated markets and MTFs? Please provide reasons for your answer.

<ESMA_QUESTION_46>

AFME Response

No, AFME believes that the table should contain the request-for quote system as per the trading systems table for non-equities on pages 150 & 151 of the DP. However, AFME refers ESMA to the response to question 119 regarding that table noting that AFME believes for the reason set out in that response that the description should be as follows:

*“A trading system where a quote or quotes are provided to a member or participant in response to a request **for a quote submitted** by one or more other members or participants. **The quote is exclusively provided to the requesting member or market participant and is indicated to be a firm quote.** The requesting member or participant may conclude a transaction by accepting the quote or quotes provided to it on request.”*

<ESMA_QUESTION_46>



Q47: Do you agree with ESMA’s view that Table 1 of Annex II of Regulation 1287/2006 is appropriate for equity-like instruments traded on regulated markets and MTFs? Are there other trading systems ESMA should take into account for these instruments? Please provide reasons for your answer.

<ESMA_QUESTION_47>

AFME Response

Yes, (subject members to check with ETF desks on RFQ systems)

<ESMA_QUESTION_47>

Q48: Do you agree with ESMA’s view that ADT remains a valid measure for determining when an order is large in scale compared to normal market size? If not, what other measure would you suggest as a substitute or complement to the ADT? Please provide reasons for your answer.

<ESMA_QUESTION_48>

AFME Response

AFME believes that the historic use of ADT as a proxy for measuring market impact does not reflect the true conditions of trading in equities. ADT does not recognise that liquidity can be episodic, e.g. it is not unusual that an instrument might trade at a size that is 100 times larger than the ADT over the previous months during a limited period linked to a news event, and is therefore likely to misrepresent liquidity for many stocks particularly at the illiquid end of the market. We provide evidence below on the distribution of trade sizes on regulated markets and MTFs for the STOXX Europe Large 200 Index (.LCXP), which under the current measure of ADT would represent the most liquid class of shares. The analysis shows that approximately 0.17% of trades are executed above the current LIS threshold. By contrast, in paragraph 45 on page 59 of the Discussion Paper, ESMA has aimed to classify 10%, 20% or 30% of the turnover of ETFs as being above the LIS threshold. If the smallest of those percentage were adopted as the aim for equities, then 10% of the turnover of shares would be protected by the LIS waiver through the introduction of an LIS threshold of EUR70,000. If this threshold is appropriate for the more liquid stocks, it will certainly be more than adequate for the less liquid universe of stocks. In the alternative ESMA may choose to have a more complex method of calculation, where this EUR70,000 threshold is reduced to EUR40,000 and EUR20,000 for the stocks with medium and small market capitalisation respectively. We enclose data which shows some deviation in trade sizes for the smaller capitalisation stocks in the spectrum. Our proposed measure can be revisited periodically for its appropriateness, but it offers simplicity in its implementation and achieves the public policy objective of preserving price discovery while protecting the larger orders from market impact.

Table 1 is the distribution of trades sizes on regulated markets and MTFs for the STOXX® Europe Large 200 index (.LCXP) on 23 July 2013. Most of these stocks have a 500k LIS – 49 have 400k and 8 have 250k. There are 2.25m trades in the sample, and only 695 (0.03%) were over EUR500,000.

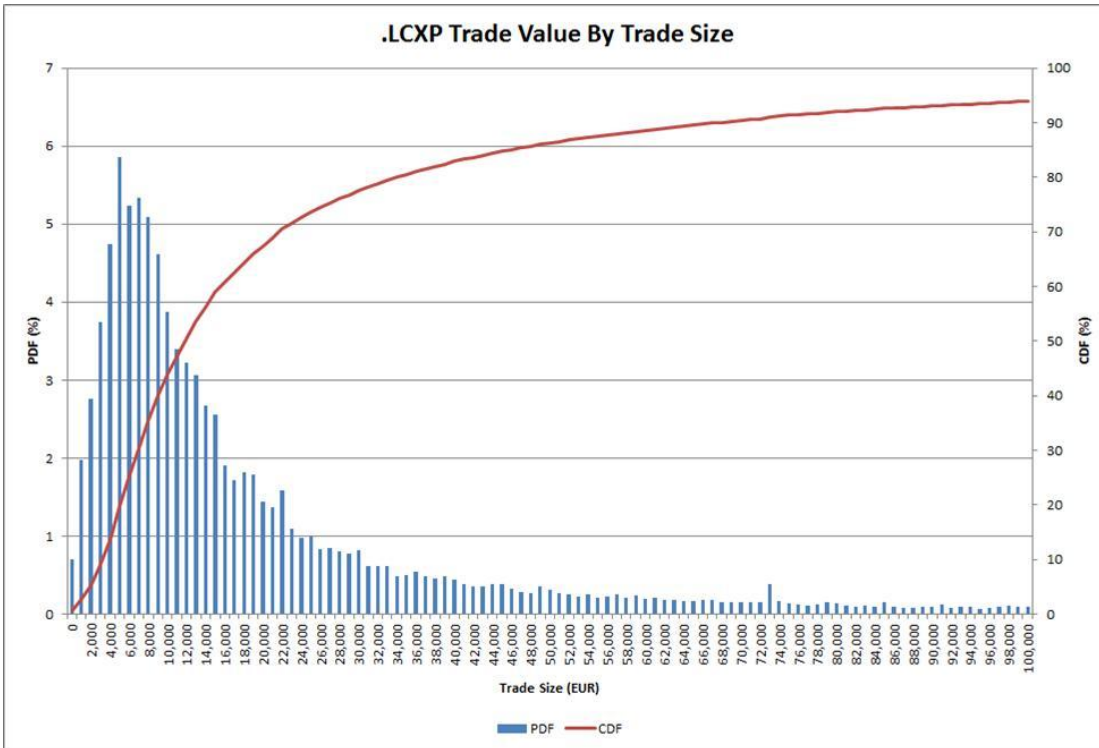

The following tables show average trade sizes for the biggest 2000 stocks traded by volume in July 2014 – below are the distributions of average trade size on the regulated market in EUR for each stock categorised by market cap.

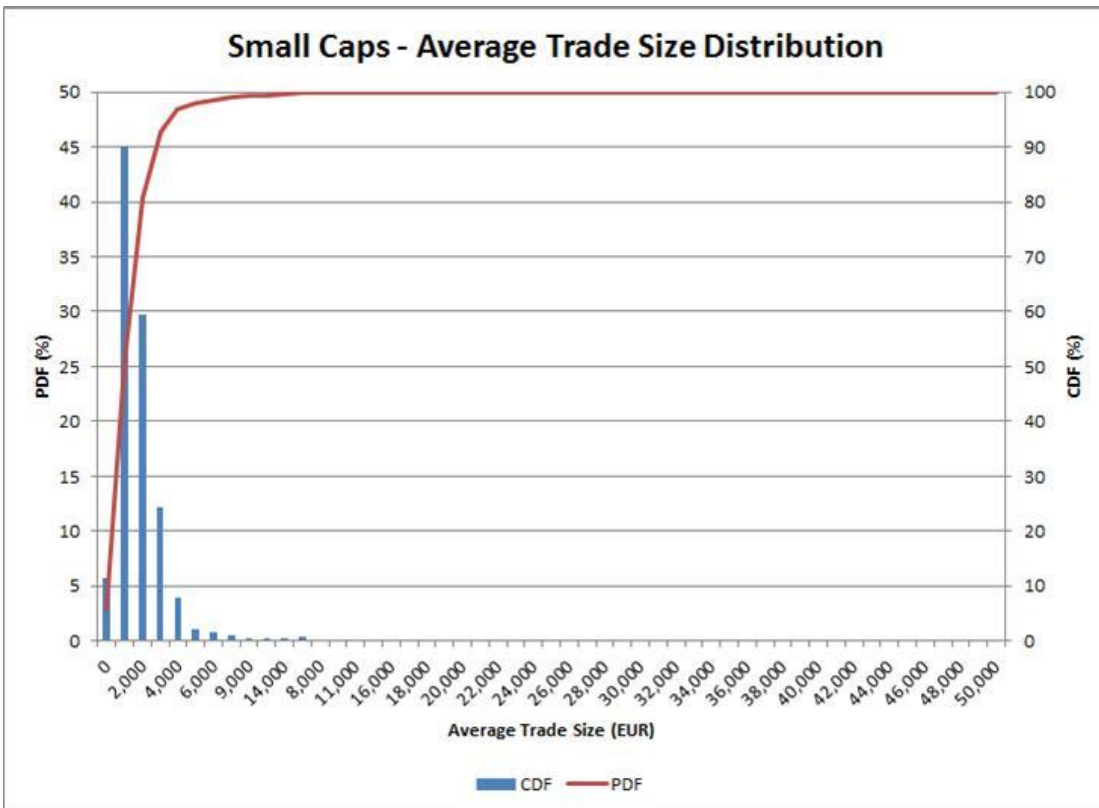

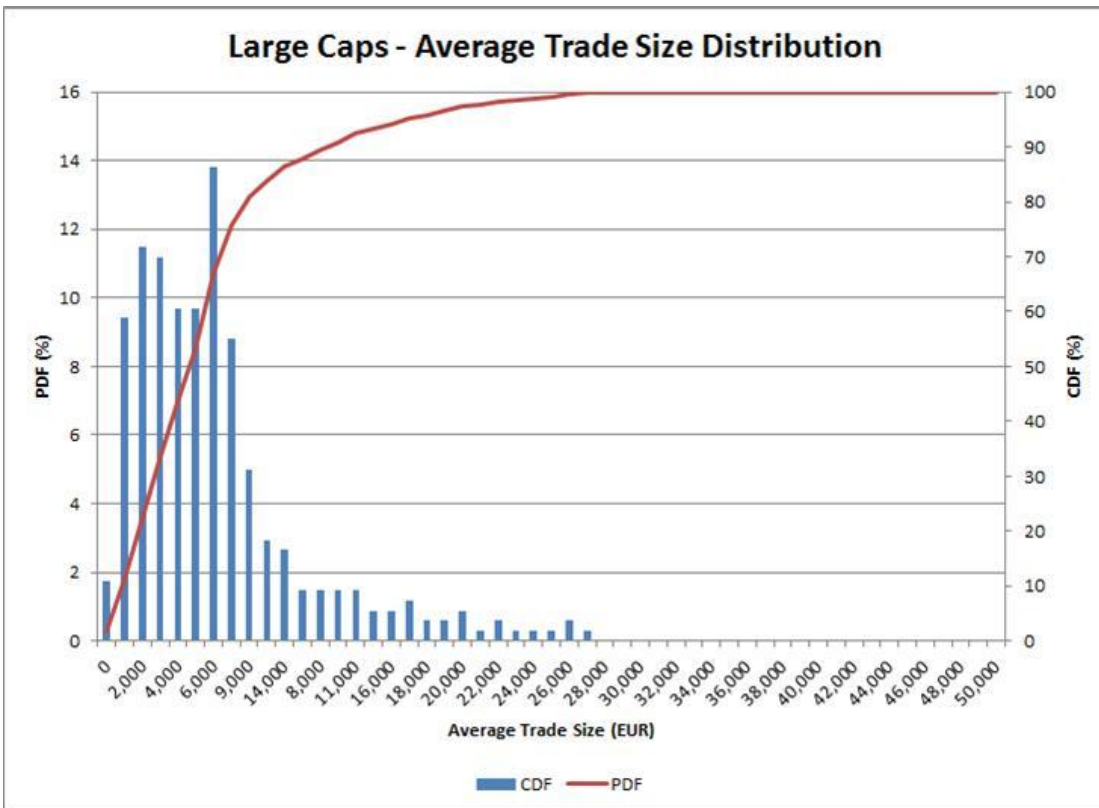
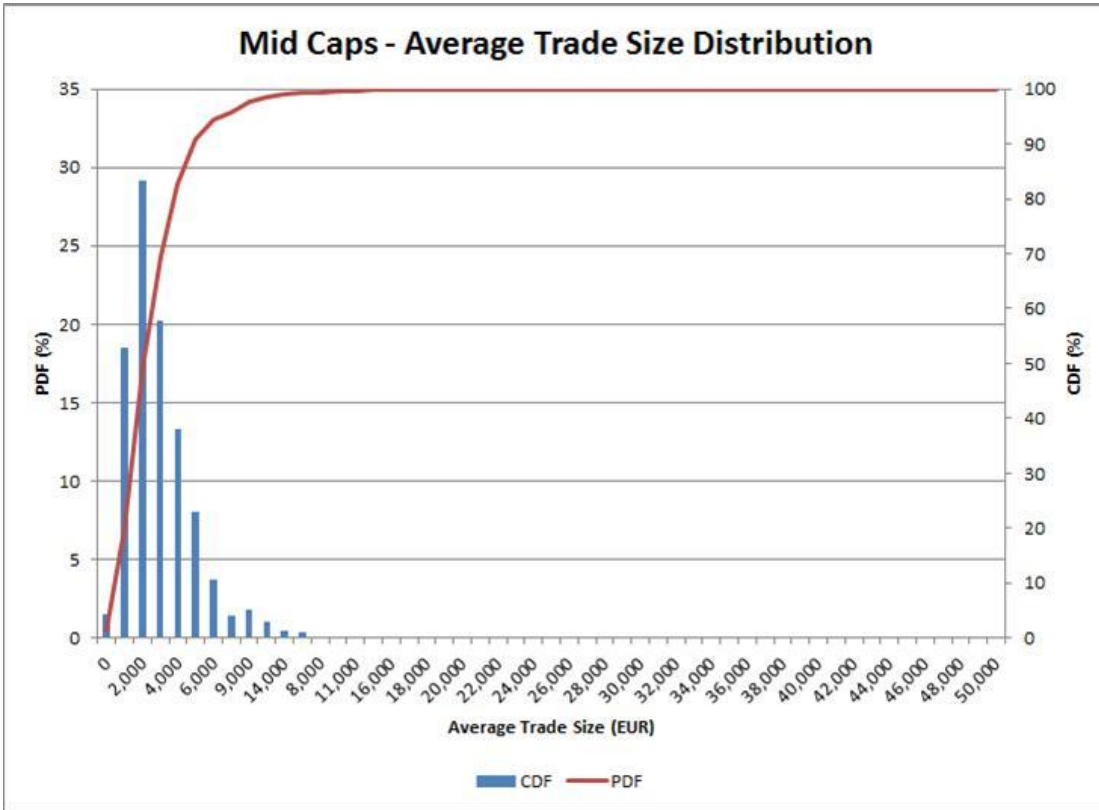

<ESMA_QUESTION_48>



Q49: Do you agree that ADT should be used as an indicator also for the MiFIR equity-like products (depository receipts, ETFs and certificates)? Please provide reasons for your answers.

<ESMA_QUESTION_49>
TYPE YOUR TEXT HERE
<ESMA_QUESTION_49>

Q50: Do you think there is merit in creating a new ADT class of 0 to €100,000 with an adequate new large in scale threshold and a new ADT class of €100,000 to €500,000? At what level should the thresholds be set? Please provide reasons for your answer.

<ESMA_QUESTION_50>

AFME Response

There may be merit to creating a lower band, but AFME refers ESMA to its comments and proposal made, with supporting data, in the response to question 48 above.

<ESMA_QUESTION_50>

Q51: Do you think there is merit in creating new ADT classes of €1 to €5m and €5 to €25m? At what level should the thresholds be set? Please provide reasons for your answer.

<ESMA_QUESTION_51>

AFME Response

There may be merit to creating greater granularity of the bandings, but AFME refers ESMA to its comments and proposal made, with supporting data, in the response to question 48 above.

<ESMA_QUESTION_51>

Q52: Do you think there is merit in creating a new ADT class for ‘super-liquid’ shares with an ADT in excess of €100m and a new class of €50m to €100m? At what level should the thresholds be set?

<ESMA_QUESTION_52>

AFME Response

No, please see the comments and proposal made, with supporting data, in the response to question 48 above, demonstrate that a super liquid band is unwarranted.

<ESMA_QUESTION_52>

Q53: What comments do you have in respect of the new large in scale transparency thresholds for shares proposed by ESMA?

<ESMA_QUESTION_53>

AFME Response

AFME is supportive of the objective that thresholds should be set at a level which recognises the purpose of the LIS threshold is to provide protection from market impact. Please therefore refer to the comments and proposal made, with supporting data, in the response to question 48 above.

<ESMA_QUESTION_53>



Q54: Do you agree with the ADT ranges selected? Do you agree with the large in scale thresholds set for each ADT class? Which is your preferred option? Would you calibrate the ADT classes and related large in scale thresholds differently? Please provide reasons for your answers, including describing your own role in the market (e.g. market-maker, issuer etc).

<ESMA_QUESTION_54>
TYPE YOUR TEXT HERE
<ESMA_QUESTION_54>

Q55: Which is your preferred scenario? Would you calibrate the ADT classes differently? Please provide reasons for your answers.

<ESMA_QUESTION_55>

AFME Response

Exchange Traded Certificates should be included given these instruments have trading characteristics in line with ETFs.

<ESMA_QUESTION_55>

Q56: Do you agree that the same ADT classes should be used for both pre-trade and post-trade transparency? Please provide reasons for your answers.

<ESMA_QUESTION_56>

AFME Response

Exchange Traded Certificates should be included given these instruments have trading characteristics in line with ETFs.

<ESMA_QUESTION_56>

Q57: How would you calibrate the large in scale thresholds for each ADT class for pre- and post-trade transparency? Please provide reasons for your answers.

<ESMA_QUESTION_57>

AFME Response

Exchange Traded Certificates should be included given these instruments have trading characteristics in line with ETFs.

<ESMA_QUESTION_57>

Q58: Do you agree with ESMA's view that the large in scale thresholds (i.e. the minimum size of orders qualifying as large in scale and the ADT classes) should be subject to a review no earlier than two years after MiFIR and Level 2 apply in practice?

<ESMA_QUESTION_58>

AFME Response

Yes

<ESMA_QUESTION_58>

Q59: How frequently do you think the calculation per financial instrument should be performed to determine within which large in scale class it falls? Which combination of frequency and period would you recommend?



<ESMA_QUESTION_59>

AFME Response

Annually

<ESMA_QUESTION_59>

Q60: Do you agree with ESMA’s opinion that stubs should become transparent once they are a certain percentage below the large in scale thresholds? If yes, at what percentage would you set the transparency threshold for large in scale stubs? Please provide reasons to support your answer.

<ESMA_QUESTION_60>

AFME Response

No, in the first instance AFME feels this adds unnecessary complexity, hindering investors ability to execute, investors rely on the protection of the whole order (including stub), and is also contingent on where LIS thresholds are set. AFME believes that LIS stubs should remain protected until completely executed. It is likely also that the cost to adjust systems at venues and for market participants to take account of such a new rule would be massively disproportionate to any marginal benefit to the broader market delivered by such a rule.

<ESMA_QUESTION_60>

Q61: Do you agree with ESMA’s view that the most relevant market in terms of liquidity should be the trading venue with the highest turnover in the relevant financial instrument? Do you agree with an annual review of the most relevant market in terms of liquidity? Please give reasons for your answer.

<ESMA_QUESTION_61>

AFME Response

AFME observes that it is a fact that there are periods in the trading day where the primary market, as the most relevant market, is not available (such as technical outages) and/ or does not have the best price available. Trading venues that wish to remain resilient, in these circumstances must be able to reference an alternative relevant market, this being a venue that has more than 5% market share.

Additionally, AFME strongly believes that ESMA's proposal to collect data to assess the caps from 1/1/16, before the regime is in place on 3/1/17 is flawed, given that both the numerator and denominator in the calculation will be much changed by all market structure changes to be put in place by MiFID II, and owing also to that the provision of any data into the cap mechanism in this period will be voluntary and is likely to be provided on an inconsistent, non-harmonised, and non-comparable basis. Specifically there are multiple changes that will likely take place including but not least volume that is currently eligible for the Reference Price Waiver at Bid or Offer price points becoming ineligible. (At a minimum any assessment should discount such flow)

<ESMA_QUESTION_61>

Q62: Do you agree with ESMA’s view on the different ways the member or participant of a trading venue can execute a negotiated trade? Please give reasons for your answer.

<ESMA_QUESTION_62>

AFME Response

This is the manner in which negotiated trade waivers currently operate and we do not see any public policy reasons for change in this area. On the contrary, it would be paramount for market participants and their clients to maintain flexibility in respect of the trades which can benefit from the use of the reference price waiver. Restricting it to just trades between two participants of the same venue would give advantageous access to the negotiated trade waiver to inter-dealer trades without giving corresponding benefits to institutional clients, who seek to protect the trading interests of European investors and pension funds.

<ESMA_QUESTION_62>

Q63: Do you agree that the proposed list of transactions are subject to conditions other than the current market price and do not contribute to the price formation process? Do you think that there are other transactions which are subject to conditions other than the current market price that should be added to the list? Please provide reasons for your answer.

<ESMA_QUESTION_63>

AFME Response

We agree with the proposed list of transactions, however, the definition of give-up/give-in transactions should be expanded to also cover transactions where an investment firm executes a trade in the market and subsequently offers to enter into a trade with another investment firm on the same terms as a ready hedge in respect of a derivative transaction entered into between that investment firm and their client.

AFME would echo ESMA's acknowledgment generally in this Discussion Paper that future implementing measures should not limit evolvments in order types and innovation in markets and would seek that ESMA add a final category to this list that allows for this circumstance.

In relation to transactions subject to conditions other than the current market price which also do not contribute to the price formation process which are not subject to the volume cap mechanism AFME would urge ESMA to clarify level 1 drafting that such trades are not subject to the volume cap mechanism. Meaning that even where the NTW/RPW is suspended for price forming trades that the NTW waiver would continue for non-price forming trades.

<ESMA_QUESTION_63>

Q64: Do you agree that these are the two main groups of order management facilities ESMA should focus on or are there others?

<ESMA_QUESTION_64>

AFME Response

Yes

<ESMA_QUESTION_64>

Q65: Do you agree with ESMA's general assessment on how to design future implementing measures for the order management facility waiver? Please provide reasons for your answer.

<ESMA_QUESTION_65>

AFME Response

Yes, but AFME would defer to exchanges to comment here.

<ESMA_QUESTION_65>



Q66: Are there other factors that need to be taken into consideration for equity-like instruments? Please provide reasons for your answer.

<ESMA_QUESTION_66>
TYPE YOUR TEXT HERE
<ESMA_QUESTION_66>

Q67: Do you agree that the minimum size for a stop order should be set at the minimum tradable quantity of shares in the relevant trading venue? Please provide reasons for your answer.

<ESMA_QUESTION_67>

AFME Response

Yes

<ESMA_QUESTION_67>

Q68: Are there additional factors that need to be taken into consideration for equity-like instruments?

<ESMA_QUESTION_68>
TYPE YOUR TEXT HERE
<ESMA_QUESTION_68>

Q69: Which minimum overall sizes for iceberg orders are currently employed in the markets you use and how are those minimum sizes determined?

<ESMA_QUESTION_69>

AFME Response

AFME would defer to exchanges and MTFs to comment here.

<ESMA_QUESTION_69>

Q70: Which minimum sizes and which methods for determining them should be prescribed via implementing measures? To what level of detail should such an implementing measure go and what should be left to the discretion of the individual market to attain an appropriate level of harmonisation?

<ESMA_QUESTION_70>

AFME Response

AFME would defer to exchanges and MTFs to comment here.

<ESMA_QUESTION_70>

Q71: Which methods for determining the individual peak sizes of iceberg orders are currently employed in European markets?

<ESMA_QUESTION_71>

AFME Response

AFME would defer to exchanges and MTFs to comment here.

<ESMA_QUESTION_71>

Q72: Which methods for determining peaks should be prescribed by implementing measures, for example, should these be purely abstract criteria or a measure expressed in percentages against the overall size of the iceberg order? To what level of details should such an implementing measure go and what should be left to the discretion of the individual market to attain an appropriate level of harmonisation?

<ESMA_QUESTION_72>

AFME Response

AFME would prefer to see a consistent approach employed by and across trading platforms for determining peaks that allows users flexibility.

<ESMA_QUESTION_72>

Q73: Are there additional factors that need to be taken into consideration for equity-like instruments?

<ESMA_QUESTION_73>

TYPE YOUR TEXT HERE

<ESMA_QUESTION_73>

3.2. Post-trade transparency - Equities

Q74: Do you agree that the content of the information currently required under existing MiFID is still valid for shares and applicable to equity-like instruments? Please provide reasons for your answer.

<ESMA_QUESTION_74>

AFME Response

Yes the content remains valid for shares and equity-like instruments

<ESMA_QUESTION_74>

Q75: Do you think that any new field(s) should be considered? If yes, which other information should be disclosed?

<ESMA_QUESTION_75>

AFME Response

Please see question 77

<ESMA_QUESTION_75>

Q76: Do you think that the current post-trade regime should be retained or that the identity of the systematic internaliser is relevant information which should be published? Please provide reasons for your response, distinguishing between liquid shares and illiquid shares.

<ESMA_QUESTION_76>

AFME Response

The suggestion that SI identity should be revealed as part of a trade report appears to flow from a mistaken belief that this is analogous to identifying the MTF or RIE where a trade has taken place. The essential difference is that in identifying an MTF or RIE no information is given as to

the identity of the parties to the trade. If the view that SIs should be identified in this way prevails then, in interest of level playing field and logical consistency, it would be essential that MTFs and RIEs are similarly obliged to identify the parties to trades on their platforms. However, we would suggest that such a significant change in market practice is worthy of explicit debate and are confident it would be seen as a proposal with little or no appeal.

Furthermore a systematic internaliser (SI) performs a significant and valuable function for investors by providing liquidity in a specific instrument. The SI performs this function through the advancement of its own capital. Exposing the name of the SI in the post-trade reports is likely to unveil to third parties the risk that the particular SI has taken in a particular instrument. This information is commercially sensitive and should not be mandated to be exposed to the public. Furthermore, the publication of this information can be expected to disincentivise the SI from performing its function.

In terms of the counterargument discussed by ESMA (that the SI quotes are made public and therefore the information is already available), we strongly disagree with the comparison between pre- and post-trade transparency. The pre-trade transparency regime for SIs is designed to inform the market of the prices available. It is not intended to give the market an understanding of how many investors have responded to those quotes. A revelation of the SI's identity would have the effect that observers would be able to reconstruct the trading activity of the investment firm which provided the quotes by revealing all executions it has concluded as an SI. The publication of this information would jeopardise confidential and commercially-sensitive information in respect of the capital advanced by the SI. It may instead provide others with an opportunity to trade in a way that would take advantage of the knowledge that a significant SI has accumulated risk in a particular instrument.

<ESMA_QUESTION_76>

Q77: Do you agree with the proposed list of identifiers? Please provide reasons for your answer.

<ESMA_QUESTION_77>

AFME Response

The list is deficient in that it fails to provide an identifier for "Order Management Waiver". Given the misinformation and paucity of facts that have beset the recent policy debate on use of waivers it is essential we have transparency over the extent of use of each waiver going forward. However, we would make the more general point that any fixed list will inevitably be found deficient in practice and to avoid perpetuating the process of solving yesterday's problem via legislative cycles we would strongly encourage ESMA to endorse mandating adherence to the MMT which has in place a governance process to ensure that it stays current. ESMA's oversight of that process may be appropriate and should be welcomed.

<ESMA_QUESTION_77>

Q78: Do you think that specific flags for equity-like instruments should be envisaged? Please justify your answer.

<ESMA_QUESTION_78>

AFME Response

No, these are covered by the already proposed identifiers, see response to question 77 above

<ESMA_QUESTION_78>

Q79: Do you support the proposal to introduce a flag for trades that benefit from the large in scale deferral? Please provide reasons for your response.

<ESMA_QUESTION_79>

AFME Response

See response to question 77 above.

<ESMA_QUESTION_79>

Q80: What is your view on requiring post-trade reports to identify the market mechanism, the trading mode and the publication mode in addition to the flags for the different types of transactions proposed in the table above? Please provide reasons for your answer.

<ESMA_QUESTION_80>

AFME Response

Yes

<ESMA_QUESTION_80>

Q81: For which transactions captured by Article 20(1) would you consider specifying additional flags as foreseen by Article 20(3)(b) as useful?

<ESMA_QUESTION_81>

TYPE YOUR TEXT HERE

<ESMA_QUESTION_81>

Q82: Do you agree with the definition of “normal trading hours” given above?

<ESMA_QUESTION_82>

AFME Response

Yes subject to normal trading hours being the continuous trading hours period and not inclusive of auctions

<ESMA_QUESTION_82>

Q83: Do you agree with the proposed shortening of the maximum permissible delay to 1 minute? Do you see any reason to have a different maximum permissible deferral of publication for any equity-like instrument? Please provide reasons for your answer

<ESMA_QUESTION_83>

AFME Response

AFME would prefer that the existing 3-minute allowance is maintained to cater for manual activity but that the requirement to report the majority of trades "as close to real time as possible" is enforced effectively to bring average reporting times down.

<ESMA_QUESTION_83>

Q84: Should the deferred publication regime be subject to the condition that the transaction is between an investment firm dealing on own account and a client of the firm? Please provide reasons for your answer.

<ESMA_QUESTION_84>

AFME Response



AFME understands that an investment firm benefits from the deferred publication regime whenever it assumes risk in a transaction.

<ESMA_QUESTION_84>

Q85: Which of the two options do you prefer in relation to the deferral periods for large in scale transactions (or do you prefer another option that has not been proposed)? Please provide reasons for your answer

<ESMA_QUESTION_85>

AFME Response

AFME does not believe any of the options presented address the real nature of the issue that is present in the current regime and feels this requires more examination and a different approach altogether.

AFME notes that whereas only Option A and Option B are presented as the choice, there are actually three options, the first of which is to maintain the current regime. In proceeding to ignore the first, status quo option, ESMA has given no rationale as to why it seems to have dismissed this option despite identifying it.

If addressing the real nature of the issue is not possible, then AFME would favour the real first option to maintain the current regime. Alternatively if AFME had to choose between Option A and Option B, then Option B is preferred as it allows deferred publication the largest transactions from late in the day (15:00 or later) to noon of the next trading day, instead of prior to the next trading day. However, for the reasons set out above AFME feels that the remaining proposals otherwise set out in Option A, repeated for Option B are inappropriate. Please see response to question 86 below for alternatives to ESMA's proposal.

The primary objective of the deferred publication regime is to deliver the net benefits of appropriate protection from the market impact of undertaking a large order to offset risk, whilst also maintaining an appropriate level of transparency.

The deferred publication regime should not seek to maximise the delay in publication for a large trade but to permit an appropriate level of delay to allow the benefits of the brokers execution techniques to be realised.

Even within a deferred publication regime, publication should be as early as possible - the regime should define the maximum possible delay. Once the primary objective has been achieved publication should be immediate.

Market impact is a function of available liquidity - for a given size of trade, greater liquidity will result in less market impact. Liquidity is a dynamic function of supply and demand and can also be significantly influenced by external factors such as relevant news or macroeconomic events.

Ideally, the deferred publication regime should be based on prevailing market conditions and AFME would reiterate its concerns highlighted at response to question 48 as to the validity of ADT as the correct measure, as it is likely to be a poor approximation for prevailing liquidity. By the same token, taking into account ESMA's own data on the current size and direction of trade sizes, logic follows that the bandings and thresholds as proposed are highly unlikely to be reflective of market impact. The absolute size of a trade is absent any context of liquidity. Delays that are determined on the basis of absolute size of trade bear no meaningful relationship to the ability to execute such a trade; and are therefore entirely arbitrary in nature.

This approach is particularly concerning as absolute size of trade is the only measure assessed for the stocks that are least liquid - where the appropriateness (or otherwise) of the deferred publication regime has potentially the greatest consequences.



The use of ADT, or the absolute size of trade, can result in permitted delays that bear little relationship to prevailing conditions and the ability to undertake offsetting trades, leading to one of two likely outcomes:

- 1) excessive delays in times of low market impact - when liquidity is high and/or volatility is low - such that trades are published too late, resulting in a lack of transparency, and
- 2) insufficient delays in times of high market impact - when liquidity is low and/or volatility is high - such that trades are published too soon, resulting in damage to the price achieved by retail investors accessing the markets through collective investments.

The current structure of the deferred publication regime results in arbitrary changes in the permitted levels of delay that do not reflect the practical reality of executing business. The resultant deferred publication delays can be varying too long, too short and inappropriate to prevailing conditions.

<ESMA_QUESTION_85>

Q86: Do you see merit in adding more ADT classes and adjusting the large in scale thresholds as proposed? Please provide alternatives if you disagree with ESMA's proposal

<ESMA_QUESTION_86>

AFME Response

Please see question 85 for comments on the merits of the current and proposed approaches. Referring to our analysis of the current and proposed thresholds tables below highlights the technical flaws in this approach, demonstrating no consistency in the thresholds across the bandings, and a particularly detrimental impact at the lower end, which risks deterring capital commitment for the stocks that need it most.

If the proposed approach is to remain then thresholds should be harmonised relative to the ADT bands and further allowance be made at the lower levels in order that SME stocks are not disproportionately disadvantaged.

| Current | | | | | Proposed | | | | | Proposed AFME Approach - Thresholds harmonised with allowance at lower levels for SME's requiring more capital | | | | |
|-------------------------------------|--|--------------|---------------|--|-------------------------------------|---|-----------------|------------------|--|--|---|-----------------|--|--|
| Average daily turnover (ADT) in EUR | Minimum qualifying size of transaction for permitted delay | % lower band | % higher band | Timing of publication | Average daily turnover (ADT) in EUR | Minimum qualifying size of transaction for permitted delay in EUR | % of lower band | % of higher band | Timing of publication | Average daily turnover (ADT) in EUR | Minimum qualifying size of transaction for permitted delay in EUR | % of lower band | Timing of publication | |
| >50m | Lower of 10% ADT and EUR 7,500,000 | 10% | | 60 minutes | >100m | 10,000,000 | 10% | | 60 minutes | >100m | 10,000,000 | 10% | 60 minutes | |
| | Lower of 20% ADT and EUR 15,000,000 | 20% | | 120 minutes | | 20,000,000 | 20% | | 120 minutes | | 20,000,000 | 20% | 120 minutes | |
| | Lower of 30% ADT and EUR 30,000,000 | 30% | | EOD (or noon next day if not in final 2 hours) | | 30,000,000 | 30% | | EOD (or at open next day if after 15:00) | | 30,000,000 | 35% | EOD (or by noon next day if after 15:00) | |
| | 100% ADT | 100% | | EOD+1 | | 7,000,000 | 14% | 1% | 60 minutes | | 5,000,000 | 10% | 60 minutes | |
| 1m-50m | 250% ADT | 250% | | EOD+2 | 50m - 100m | 15,000,000 | 30% | 2% | 60 minutes | 50m - 100m | 10,000,000 | 20% | 120 minutes | |
| | Greater of 10% ADT and EUR 3,500,000 | 10% | 10% | EOD+3 | | 25,000,000 | 50% | 3% | EOD (or at open next day if after 15:00) | | 17,500,000 | 35% | EOD (or by noon next day if after 15:00) | |
| | Lower of 15% ADT and EUR 10,000,000 | 15% | 15% | 180 minutes | 25m - 50m | 10,000,000 | 40% | 20% | 120 minutes | 25m - 50m | 5,000,000 | 20% | 120 minutes | |
| | Lower of 25% ADT and EUR 5,000,000 | 25% | 25% | EOD (or noon next day if not in final 2 hours) | | 12,000,000 | 48% | 24% | EOD (or at open next day if after 15:00) | | 8,750,000 | 35% | EOD (or by noon next day if after 15:00) | |
| 100,000-1m | Greater of 25% ADT and EUR 100,000 | 100% | 25% | EOD | 5m - 25m | 2,500,000 | 50% | 10% | 60 minutes | 5m - 25m | 300,000 | 10% | 60 minutes | |
| | 100% ADT | 100% | 100% | EOD+1 | | 4,000,000 | 80% | 15% | 120 minutes | | 500,000 | 20% | 120 minutes | |
| | Greater of 50% ADT and EUR 1,000,000 | 50% | 50% | EOD+2 | | 5,000,000 | 100% | 20% | EOD (or at open next day if after 15:00) | | 1,950,000 | 35% | EOD (or by noon next day if after 15:00) | |
| | 250% ADT | 250% | 250% | EOD+3 | 1m-5m | 450,000 | 45% | 5% | 60 minutes | 1m-5m | 60,000 | 10% | 60 minutes | |
| <100 k | Greater of 5% ADT and EUR 25,000 | 25% | 5% | 60 minutes | | 750,000 | 75% | 15% | 120 minutes | | 120,000 | 20% | 120 minutes | |
| | Greater of 15% ADT and EUR 75,000 | 75% | 15% | 180 minutes | | 1,900,000 | 100% | 20% | EOD (or at open next day if after 15:00) | | 210,000 | 35% | EOD (or by noon next day if after 15:00) | |
| | Greater of 25% ADT and EUR 100,000 | 100% | 25% | EOD (or noon next day if not in final 2 hours) | | 75,000 | 15% | 5% | 60 minutes | | 30,000 | 10% | 60 minutes | |
| | 100% ADT | 100% | 100% | EOD+1 | 500,000-1m | 150,000 | 30% | 15% | 120 minutes | 500,000-1m | 60,000 | 20% | 120 minutes | |
| | 250% ADT | 250% | 250% | EOD+2 | | 225,000 | 45% | 23% | EOD (or at open next day if after 15:00) | | 105,000 | 35% | EOD (or by noon next day if after 15:00) | |
| | EUR 10,000 | 10% | | 60 minutes | | 30,000 | 30% | 5% | 60 minutes | | 6,000 | 10% | 60 minutes | |
| | EUR 25,000 | 25% | | 180 minutes | | 80,000 | 80% | 16% | 120 minutes | | 12,000 | 20% | 120 minutes | |
| | EUR 45,000 | 45% | | EOD (or noon next day if not in final 2 hours) | | 120,000 | 120% | 24% | EOD (or at open next day if after 15:00) | | 21,000 | 35% | EOD (or by noon next day if after 15:00) | |
| | EUR 60,000 | 60% | | EOD+1 | | 15,000 | 15% | | 60 minutes | | 6,000 | 10% | 60 minutes | |
| | EUR 80,000 | 80% | | EOD+2 | | 30,000 | 30% | | 120 minutes | | 12,000 | 20% | 120 minutes | |
| | | >80% | | EOD+3 | | 50,000 | 50% | | EOD (or at open next day if after 15:00) | | 21,000 | 35% | EOD (or by noon next day if after 15:00) | |

<ESMA_QUESTION_86>

Q87: Do you consider the thresholds proposed as appropriate for SME shares?

<ESMA_QUESTION_87>

AFME Response

Please see response to questions 85 and 86 above. The market impact for a trade representing a given percentage of ADT is smaller as ADT increases. Consequently, the greatest delays are ap-



appropriate in the least liquid stocks where market impact is greatest. The structure of the proposed deferred publication regime remains inconsistent with this observation.

<ESMA_QUESTION_87>

Q88: How frequently should the large in scale table be reviewed? Please provide reasons for your answer

<ESMA_QUESTION_88>

AFME Response

Annually

<ESMA_QUESTION_88>

Q89: Do you have concerns regarding deferred publication occurring at the end of the trading day, during the closing auction period?

<ESMA_QUESTION_89>

AFME Response

AFME prefers Option B which provides for deferred publication until noon the following day for the particular reason that such publication would have a price distorting effect during the closing auction period.

<ESMA_QUESTION_89>

Q90: Do you agree with ESMA's preliminary view of applying the same ADT classes to the pre-trade and post-trade transparency regimes for ETFs? Please provide reasons for your answer.

<ESMA_QUESTION_90>

AFME Response

No, AFME would propose factoring in the underlying liquidity of the basket or index being tracked.

<ESMA_QUESTION_90>

3.3. Systematic Internaliser Regime - Equities

Q91: Do you support maintaining the existing definition of quotes reflecting prevailing market conditions? Please provide reasons for your answer.

<ESMA_QUESTION_91>

AFME Response

Yes

<ESMA_QUESTION_91>



Q92: Do you support maintaining the existing table for the calculation of the standard market size? If not, which of the above options do you believe provides the best trade-off between maintaining a sufficient level of transparency and ensuring that obligations for systematic internalisers remain reasonable and proportionate? Please provide reasons for your answer.

<ESMA_QUESTION_92>

AFME Response

AFME favours Option A and believes it is the only permissible option for the following reasons:

MiFID stipulates that “The standard market size for each class of shares, depositary receipts, exchange-traded funds, certificates and other similar financial instruments shall be a size representative of the arithmetic average value of the orders executed in the market for the financial instruments included in each class”.

AFME observes that according to the table presented by ESMA on page 97 of the discussion paper, the average trade size* in 2013 in the lowest (EUR 7,500) band is approximately EUR 3,700. AFME rejects the assertion made in paragraph 22. ii that this pattern of trading since 2007/2008 is atypical, and instead feels that current average trade sizes are a fair representation of current and persisting trading patterns. For some 30% of securities in the lowest band, SMS is currently over three times the average trade size. SMS clearly no longer adequately represents the average trade size of the securities of that class (due to market evolution) and we would welcome its recalibration.

Option A would go some way to remediating the mismatch, although AFME members observe that this would still leave some seven redundant bands whilst placing 95% of securities into two bands with significant variation in trade size. Option B, on the other hand, would place 95% of securities into a single band and make SMS un-representative of average trade size for the overwhelming majority of securities. Given the specification provided by MiFID, AFME does not feel that option B could be justified. Option A should be selected.

* By observing the three sub bands provided (0-2500,2500-5000,5000-10000) and weighting the mid of each band by the proportion of securities in each band.

<ESMA_QUESTION_92>

Q93: Do you agree with the proposal to set the standard market size for depositary receipts at the same level as for shares? Please provide reasons for your answer.

<ESMA_QUESTION_93>

AFME Response

Yes

<ESMA_QUESTION_93>

Q94: What are your views regarding how financial instruments should be grouped into classes and/or how the standard market size for each class should be established for certificates and exchange traded funds?

<ESMA_QUESTION_94>

TYPE YOUR TEXT HERE

<ESMA_QUESTION_94>

3.4. Trading obligation for shares (Article 23, MiFIR)

Q95: Do you consider that the determination of what is non-systematic, ad-hoc, irregular and infrequent should be defined within the same parameters applicable for the systematic internaliser definition? In the case of the exemption to the trading obligation for shares, should the frequency concept be more restrictive taking into consideration the other factors, i.e. ‘ad-hoc’ and ‘irregular’?

<ESMA_QUESTION_95>

AFME Response

AFME does not agree with ESMA’s suggestion at paragraph 8 on page 101 that what is considered as non-systematic, ad-hoc, irregular and infrequent in the context of OTC trading should be defined using the same parameters as the SI regime. Many AFME members may qualify as an SI for the majority of names that they trade and as such, will be publishing quotes and where appropriate executing trades within this structure. This does not however mean that on an ad-hoc, non systematic, irregular and infrequent basis these firms will not need to trade on an OTC basis to best meet the complex needs of their clients.

The ability to allow a firm to trade OTC in line with also facilitating business via their SI is important for several reasons. A core function to a broker dealer is to facilitate business on behalf of its clients with such requests and trade structures varying considerably. Whilst many trades will be on risk and suitable for the SI framework, there may be non-systemic, ad hoc, irregular and infrequent situations where clients would be best served by an OTC execution – for example when trading in significant sizes clients may look to their broker to manually find the other side to their trade, thus executing an agency cross. AFME members fully support the objectives of the trading obligation to further increase transparency in the equity markets, but believe that using the SI thresholds in the proposed manner would serve to extend the scope of the trading obligation in a way that would ultimately be to the detriment of investors.

<ESMA_QUESTION_95>

Q96: Do you agree with the list of examples of trades that do not contribute to the price discovery process? In case of an exhaustive list would you add any other type of transaction? Would you exclude any of them? Please, provide reasons for your response.

<ESMA_QUESTION_96>

AFME Response

AFME would add Give-up/give-in and securities financing transactions to this list, making it consistent with ESMA’s list at section 3.1, paragraph 75, of this Discussion Paper. However, as previously mentioned in the response to question 63, the definition of give-up/give-in transactions should be expanded to also cover transactions where an investment firm executes a trade in the market and subsequently offers to enter into a trade with another investment firm on the same terms as a ready hedge in respect of a derivative transaction entered into between that investment firm and their client.

Additionally AFME would echo ESMA’s acknowledgment generally in this Discussion Paper that future implementing measures should not limit evolvments in order types and innovation in markets and would seek that ESMA add a final category to this list that allows for this circumstance.

Furthermore, the types of transactions listed should not be considered exhaustive in nature and should operate as a safe harbour with allowance being made for transactions that do not contribute to the price formation process but takes place as an adjunct to a market trade, similar to give up/give-in transactions. One example of such a transaction would be the exchange of ordinary shares for ADRs in which the buyer transfers to the seller either (a) depositary shares representing a corresponding amount of ordinary shares and receives in return from the sell; or (b) ordinary shares and receives in return from the seller the equivalent ordinary shares or depositary shares evidencing ordinary shares, as the case may be, with the functional goal of operationally moving the security between markets. As with give up/give-in transactions, such trades can be characterized as non-addressable liquidity trades where the nature of the trade is such that it is restricted to the particular trading interests of predetermined counterparties and/or due to pure technical reasons. Other examples would be: transfers of shares as collateral; physical delivery at expiry of a derivative; and, physical delivery at any stage during the life of s structured note, which also serves to demonstrate how difficult it is to achieve an exhaustive list.

Separately AFME thinks that more generally the trading obligation for shares (art 23 MiFIR) needs to be clarified to make clear that where an investment firm is trading on a riskless principal basis the trading obligation does not apply to the client leg of the riskless principal transaction. The corresponding transaction with the client should not be subject to an additional trading obligation as this will have been satisfied by the investment firm's activity on the trading venue.

<ESMA_QUESTION_96>

Q97: Do you consider it appropriate to include benchmark and/or portfolio trades in the list of those transactions determined by factors other than the current valuation of the share? If not, please provide an explanation with your response.

<ESMA_QUESTION_97>

AFME Response

Yes

<ESMA_QUESTION_97>

3.5. Introduction to the non-equity section and scope of non-equity financial instruments

Q98: Do you agree with the proposed description of structured finance products? If not, please provide arguments and suggestions for an alternative.

<ESMA_QUESTION_98>

AFME Response

FIXED INCOME

No. AFME does not agree

(i) ***Clarification is needed that there are different levels of risk transfer in securitisation and no security has 100% credit risk transfer and CDOs should be classed as re-securitisations***

Structured finance products are defined in MiFIR Article 2(1)(28) as “those securities created to securitise and transfer credit risk associated with a pool of financial assets entitling the security holder to receive regular payments that depend on the cash flow from the underlying assets”. Whilst we don’t disagree with this definition, it is essential to clarify that the purpose of the security to transfer of credit risk should not be a test for the definition of structured finance products but more of a feature. There are different levels of risk transfer in securitisation deals and no security has 100% credit risk transfer.

We agree with the ESMA’s approach to limit the category of Structured Finance Products to securitised debt (as provided in MiFIR Article 2(1)(28)). Further, we also agree with CESR’s guidance.

Also, it is important to clarify that CDOs are resecuritisations and not just simply securitisations.

(ii) ***ABCPs should not fall within SFPs but should be classified as money market instruments***

A securitisation, as set out in MiFIR Article 2(1)(8), depends on the cash flow of assets. ABCPs are based on underlying assets that are supported by liquidity and credit enhancement provided by a sponsor bank (a liquidity line); therefore, ABCPs are not dependent on the underlying assets in the same way as a standard ABS but is more dependent on the sponsor bank.

Further, (as we answered in **CP Question 121**) the reasoning that ESMA has provided is that ABCPs are both structured finance products and money market instruments and as such should be treated as structured finance products. If the same logic is applied to commercial paper, which ESMA has deemed a money market instrument, commercial paper should be considered like any other bond because the only difference is that it has a very short term. Therefore, the reasoning is inappropriate.

The only difference between a commercial paper and an ABCP is that the cash flows of an ABCP are derived from an underlying pool of assets.

(iii) ***Securitised derivatives should be classed as SFPs and not derivatives***

We recommend that securitised derivatives are SFPs and not derivatives. They do not have the same legal arrangements, documentation or market infrastructure as derivatives. Specifically, they are derivatives that have been securitised. These instruments have all the features of a typical bond (e.g. an ISIN) and should, therefore, fall within the category of an SFP.

We agree that there are challenges to distinguishing securitised debt from standard corporates to the extent that they are both transferable securities and analysis of the prospectus would be required to make a categorisation determination.

Further, securitised derivatives are not covered by the definition of derivatives under EMIR. We urge ESMA to ensure consistency between the definitions of derivatives in EMIR and MiFID.

Ultimately, we do not believe that they should receive a different treatment from SFPs and other bonds.

Throughout the response to the CP and DP, whenever AFME makes a recommendation regarding SFPs, it is intended that securitised derivatives receive the same treatment (i.e. they are in scope of SFPs).



<ESMA_QUESTION_98>

Q99: For the purposes of transparency, should structured finance products be identified in order to distinguish them from other non-equity transferable securities? If so, how should this be done?

<ESMA_QUESTION_99>

AFME Response

FIXED INCOME

No. AFME believes that SFPs should be treated in the same way. Separating SFPs from other bonds and SFPs would introduce further complexity.

<ESMA_QUESTION_99>

Q100: Do you agree with the proposed explanation for the various types of transferable securities that should be treated as derivatives for pre-trade and post trade transparency? If not, please provide arguments and suggestions for an alternative.

<ESMA_QUESTION_100>

AFME Response

FIXED INCOME

No. AFME does not agree.

We recommend that securitised derivatives are SFPs and are not derivatives - they do not have the same legal arrangements, documentation or market infrastructure as derivatives. Specifically, they are derivatives that have been securitised. These instruments have all the features of a typical bond (e.g. an ISIN) and should, therefore, fall within the category of an SFP.

Throughout the response to the CP and DP, whenever AFME makes a recommendation regarding SFPs, it is intended that securitised derivatives receive the same treatment (i.e. they are in scope of SFPs).

Further, securitised derivatives are not covered by the definition of derivatives under EMIR. We urge ESMA to ensure consistency between the definitions of derivatives in EMIR and MiFID.

<ESMA_QUESTION_100>

Q101: Do you agree with ESMA's proposal that for transparency purposes market operators and investment firms operating a trading venue should assume responsibility for determining to which MiFIR category the non-equity financial instruments which they intend to introduce on their trading venue belong and for providing their competent authorities and the market with this information before trading begins?

<ESMA_QUESTION_101>

AFME Response

FIXED INCOME

No. AFME does not agree.

Categorisation of instruments should be centralised or ESMA should produce a detailed taxonomy such that implementation can be automated and consistent.

We recommend that categorisation of instruments should be centralised and should not be undertaken at investment firm level. Also, as set out in our response to **DP Question 573**, we

do not agree that investment firms should provide reference data (needed for categorisation), we believe that appropriate data can be obtained from venues (which will be providing the information for the daily lists for the reference data and scope of instruments). The exercise for investment firms is duplicative and unnecessary.

Instead, we propose that once an instrument is traded on a venue for the first time, the first venue send the ISIN and the reference data to the NCA (which directly is fed into ESMA) and an automatic categorisation is applied by ESMA using a detailed taxonomy based on the reference data submitted. ESMA can also check and assess whether the correct categorisation has been applied. We highlight that prospectuses are not machine readable – meaning that the population of the elements of the taxonomy will be critical. We refer ESMA to our response to **DP Questions 573 and 568**.

We also propose that ESMA produce a clear methodology for classifying instruments – which should be based on the prospectus of the instrument rather than uncodified market standards that are not widely used (such as CFI indicators).

We do not believe it is appropriate for operators of venues or investment firms operating venues to be responsible for actively categorising instruments, for the following reasons:

- ***The categorisation exercise would be highly duplicative resulting in slow operational process***

The same instrument can trade on multiple venues. If every venue was responsible for categorising the instrument, the exercise would be duplicative, which would slow and intensify processing when the information is centralised.

- ***Categorisation involves a high level of subjectivity resulting in a many inconsistencies for the same instrument***

Categorisation requires subjectivity because the asset class of an instrument is not set out in the prospectus of that instrument. As a result, there would be inconsistencies in the way different venues apply ESMA's methodology. Inconsistencies would arise even if ESMA introduced specific methodologies.

For example, one exercise of categorisation is the differentiation of instruments into different asset classes. Such a categorisation involves a certain level of subjectivity and interpretation. For example, there are certain types of corporate debt that have senior and subordinated tranches but would not be considered a SFP.

This inconsistency in categorisation will result in national authorities collecting different information on the same instrument that will need to be corrected and then consolidated – otherwise, there will be a Europe-wide fragmented and inconsistent approach. This will again slow the processing of information.

- ***There will be unintended consequences when an instrument is wrongly categorised***

We also believe that there will be unintended consequences if venues are responsible for determining the category of instruments prior to trading if any errors occur. The result will be that an instrument may be categorised incorrectly and will be subject to the wrong transparency regime (especially if ESMA adopts the COFIA approach).

FOREIGN EXCHANGE



The Global Foreign Exchange Division (GFXD, its members comprise 23 global Foreign Exchange (FX) market participants, collectively representing more than 90% of the FX inter-dealer market) of the Global Financial Markets Association (GFMA) has continually supported the view that regulatory deliverables should be aligned on a global basis. Such an approach offers regulators the ability to accurately consolidate data across jurisdictional boundaries, allows market participants to transact on a consistent basis and prevents market fragmentation as well as exposing market participants to any undue, increased costs due to jurisdictional specific deliverables.

The GFXD therefore proposes that for FX there is a globally consistent implementation of regulatory transparency and trading obligations. We believe that, due to the cross border nature of the FX market, market participants should not be disadvantaged by inconsistent application.

The global FX market presents unique challenges with respect to implementing global regulatory requirements, primarily due to the vast number of market participants, the global nature of the FX market place and the wide variety of execution methods. FX forms the basis of the global payments system and as such the volume of transactions is high and notional turnover, (as reported by the Bank of International Settlements in their Triennial Central Bank Survey: Foreign Exchange Turnover in April 2013

(<http://www.bis.org/publ/rpfx13fx.pdf>) is US\$5.3 trillion/day, with 41% of this being conducted from London.

The primary step in determining globally consistent transparency policies and globally consistent trading obligations is to define the instruments that are to be impacted by such regulation. For FX, the GFXD supports the existing International Swaps and Derivatives Association, Inc (ISDA) product taxonomies, (http://www2.isda.org/attachment/NTQzOQ--/ISDA_OTC_Derivatives_Taxonomies_o_version2012-10-22.xls). A consistent framework allows harmonization on a regional and global basis, providing consistency and certainty to market participants and allows an effective regulatory outcome. Specifically for FX, the FX table included within Annex 3.6.1 (Financial instruments taxonomy and metrics for the calculation of the liquidity criteria (average size of transaction) on page 134 of the Discussion Paper includes similar taxonomy to that included within the ISDA product taxonomy and the GFXD recommends that this should be used by trading venues and market participants alike to determine the categorization of the FX instruments they are trading. The GFXD believes that any additional changes to this categorization should be made through a consultative process with market participants, with the final approval for any changes being made by ESMA and the European National Competent Authority (NCA) community.

Whilst we agree that a trading venue, utilizing the above categorization, should take responsibility for informing the market on the instruments they intend to introduce, we would expect that either ESMA or the NCA community ensures that when an instrument is available on multiple venues that it is being consistently categorized, and validated in an independent fashion, especially given that each trading venue will be operating in a commercial capacity.

With specific reference to Annex 3.6.1 on page 134 of the Discussion Paper, the GFXD would like to state that the reference to 'cash settled forwards' be replaced with physically (deliverable) settling FX forward transactions because cash settled forwards are non-deliverable forward transactions. A non-deliverable forward is an FX financial instrument that involves two transacting parties executing an FX forward contract on the basis of non-delivery (i.e. cash, not physical, settlement) which involves the fixing (i.e. valuation) of the contract and therefore settlement in single reference currency. We also suggest that the 'FX Swap' product type should be broken down at the sub-product type to 'Deliverable Swaps' and 'Non-Deliverable Swaps'. Finally, we would like to state, with reference to the ESMA EMIR Q&A, TR Question 1, that cross-currency



swaps are 'financial instruments should be classified as interest rates, in line with current market practice' rather than as FX instruments. Table 1 below shows a representative illustration of how Annex 3.6.1 could look for FX.

Table 1: Suggested Annex 3.6.1 for FX

| Financial Instrument | Product Types | Sub-Product Types | Recommended Liquidity sub-categories |
|------------------------------|---------------|--|--------------------------------------|
| Foreign Exchange Derivatives | Futures | N/A | Currency Pair Maturity |
| | Options | Non-Deliverable Option - NDO (only European type options are NDO - not any other FX options settled in non-deliverable currency) | |
| | | Vanilla Option (European and American) | |
| | Forwards | Deliverable Forward | |
| | | NDF | |
| | FX Swaps | Deliverable FX Swap | |
| | | Non-Deliverable FX Swap | |
| | Others | Simple exotic (Barrier & Digital) | |
| | | Complex Exotic | |

<ESMA_QUESTION_101>

Q102: Do you agree with the definitions listed and proposed by ESMA? If not, please provide alternatives.

<ESMA_QUESTION_102>

AFME Response

FIXED INCOME

No. AFME does not agree.

(i) The definition of a bond should include bonds that are issued by non-EU governments or other non-EU entities

The definitions for sovereign bonds, corporate bonds and covered bonds, only includes bonds issued by an EU government/entity. We do not believe that this is appropriate. It is critical that there is equivalent treatment for EU and non-EU bonds – otherwise there could be unintended consequences.

*One such consequence is that **ESMA could introduce a global unlevel playing field by encouraging different regimes for bonds depending on the country of issuance***

For example, ESMA is proposing that bonds issued by non-EU governments, agents or supranationals should not qualify as sovereign bonds. If non-EU instruments are subject to a stricter regime than European issued government debt, it will discourage trading in those instruments, thereby making it more expensive for European investors to diversify their investments.

Notably, if a European firm trades a US Treasury and a European government bond with a US firm, neither will be subject to the US transparency regime but both will be in scope of the European regime with a potentially stricter treatment for US Treasuries.

To illustrate the significance of non-EU government bonds, based on trading data AFME has obtained from TRAX¹, 51.19% of government bonds that traded in Europe were non-EU (of the sample set). In terms of traded volumes and number of trades, in May 2013, approximately 14% of volume was in non-EU government bonds and 15% of transactions were in non-EU government bonds.

(ii) AFME agrees with the definitions of sovereign bonds and covered bonds, except for the exclusion of non-EU bonds

(iii) AFME recommends that the definition of corporate bonds needs to include bonds issued by a number of other types of entities – the use of the Company Law Directive is too limiting

These include:

- Bonds issued by LLPs
- Bonds issued by building societies, industrial and provident societies,
- Bonds issued by corporations created by charter, e.g. certain universities
- Bonds issued by charities

(iv) Securitised derivatives are SFPs and not derivatives

We recommend that securitised derivatives are SFPs and not derivatives. They do not have the same legal arrangements, documentation or market infrastructure as derivatives. Specifically, they are derivatives that have been securitised. These instruments have all the features of a typical bond (e.g. an ISIN) and should, therefore, be classified as a SFP.

¹ AFME has undertaken testing on trade data provided by TRAX. 10,091 traded fixed income bonds were randomly chosen from six asset classes (government bonds, surpranationals, corporate bonds, high yield, covered bonds and securitisation). Trade data for these securities was tested over the period 1 October 2011 to 30 September 2013. Given that these securities were chosen at random, we can assume that this universe is proportionally representative.

We agree that there are challenges to distinguishing securitised debt from standard corporates to the extent that they are both transferable securities and analysis of the prospectus would be required to make a categorisation determination.

Further, securitised derivatives are not covered by the definition of derivatives under EMIR. We urge ESMA to ensure consistency between the definitions of derivatives in EMIR and MiFID.

Ultimately, we do not believe that they should receive a different treatment from SFPs and other bonds.

Throughout the response to the CP and DP, whenever AFME makes a recommendation regarding SFPs, it is intended that securitised derivatives receive the same treatment (i.e. they are in scope of SFPs).

(v) *The definition of a convertible bond is confusing and introduces ambiguity as to whether an instrument is a convertible bond or a securitised derivative*

We propose the following amendment to the definition:

A convertible bond is a hybrid instrument consisting of a bond ~~or securitised debt with an embedded derivative, normally an option to acquire the underlying equity of the issuing company~~ that can be converted into a specified amount of the issuing company's equity or cash of equal value, usually at the discretion of the holder.

The text that we propose to delete is not only ambiguous but also superfluous.

FOREIGN EXCHANGE:

For FX, the GFXD understands that the definitions proposed in relation to question 102 concerns the Structured Finance and cash Fixed Income markets.

Specifically for FX, as referenced in our response to question 101, we would like to support the definitions referenced in Annex 3.6.1 on page 134 of the Discussion Paper, themselves derived from the ISDA product taxonomies

http://www2.isda.org/attachment/NTQzOQ--/ISDA_OTC_Derivatives_Taxonomies_o_version2012-10-22.xls

With specific reference to Annex 3.6.1 on page 134 of the Discussion Paper, the GFXD would like to state that the reference to 'cash settled forwards' be replaced with physically (deliverable) settling FX forward transactions, because cash settled forwards are non-deliverable forward transactions. A non-deliverable forward is an FX financial instrument that involves two transacting parties executing an FX forward contract on the basis of non-delivery (i.e. cash, not physical, settlement) which involves the fixing (i.e. valuation) of the contract and therefore settlement in single reference currency. We also suggest that the 'FX Swap' product type should be broken down at the sub-product type to 'Deliverable Swaps' and 'Non-Deliverable Swaps'. Finally, we would like to state, with reference to the ESMA EMIR Q&A, TR Question 1, that cross-currency swaps are 'financial instruments should be classified as interest rates, in line with current market practice' rather than as FX instruments. Table 2 below shows a representative illustration of how Annex 3.6.1 could look for FX.

Table 2: Suggested Annex 3.6.1 for FX

| Financial Instrument | Product Types | Sub-Product Types | Recommended Liquidity sub-categories |
|------------------------------|---------------|--|--------------------------------------|
| Foreign Exchange Derivatives | Futures | N/A | Currency Pair |
| | Options | Non-Deliverable Option - NDO (only European type options are NDO - not any other FX options settled in non-deliverable currency) | |
| | | Vanilla Option (European and American) | |
| | Forwards | Deliverable Forward | |
| | | NDF | |
| | FX Swaps | Deliverable FX Swap | |
| | | Non-Deliverable FX Swap | |
| | Others | Simple exotic (Barrier & Digital) | |
| | | Complex Exotic | |

<ESMA_QUESTION_102>

3.6. Liquid market definition for non-equity financial instruments

Q103: Do you agree with the proposed approach? If you do not agree please provide reasons for your answers. Could you provide for an alternative approach?

<ESMA_QUESTION_103>

AFME Response

FIXED INCOME

No. AFME does not agree.

We propose option 1 is the most appropriate parameter if the period of calculation is sufficiently dynamic - the period for calculation needs to be monthly not yearly

To ensure a simple and implementable regime, we agree with an approach based on absolute numbers rather than using a relative concept. We recommend Option 1 for bonds and SFPs: the number of transactions in a given time period is a sufficient parameter for liquidity if the calibration is sufficiently dynamic.

With regards to the time period, we propose a **monthly** calibration. We recommend that a monthly retrospective calibration will be sufficiently dynamic to detect changes in liquidity but will ensure a model that is not too volatile. We agree with ESMA that defining the time period is critical and that the longer the time period, the higher the risk of skewed distribution. Further, we acknowledge that a shorter the time period may introduce more operational complexity; however, this is mitigated if a simple operational structure is introduced, that is optimally automated (as discussed in response to **DP Questions 132 and 178**)

A yearly calibration is inappropriate for fixed income bonds

We strongly recommend that a yearly period for the calculation and calibration of average frequency of trades (i.e. number of trades in a year) is not appropriate for fixed income. Currently, a yearly calibration is used for equities. Even for equities, where instruments do not mature and where there are not multiple securities issued per issuer, a yearly calibration for equities is suboptimal. For fixed income, a yearly calibration is not workable. The reasons that an annual calibration is inappropriate are:

Fixed income securities mature meaning that liquidity is more dynamic

One of the reasons that a yearly calibration for fixed income instruments does not work is that they mature. Given that fixed income instruments have maturity dates, the liquidity of these instruments changes dynamically over time. For example, one of the most notable features of bonds is that trading activity tends to be much greater within the first few months from issuance.

An annual calibration would be meaningless for shorter term instruments

Many bonds have relatively short terms; this means that they have a short liquidity life cycle, for these shorter term instruments, an annual calibration is even less meaningful. The significance of these shorter-term instruments is illustrated below. For example, for a three-year bond, a whole year of time would need to pass before the liquidity of the instrument is assessed and then the second year of the bond (one year before maturity) would be based on the first year. As discussed above, the secondary market activity of an instrument within the first few months issuance is very different from the activity of an instrument in the following year.

Using government bond trading data from AFME's analysis of TRAX data², of the government bonds in the sample set with terms of two years or more, one quarter was made up of instru-

² AFME has undertaken testing on trade data provided by TRAX. 10,091 traded fixed income bonds were randomly chosen from six asset classes (government bonds, supranationals, corporate bonds, high yield, covered bonds and securitisation). Trade data for these securities was tested over the period 1 October

ments with terms of 2-5 years. For corporate bonds in the sample set with maturities from issuance of two years of more, approximately, 42% was made up of securities with terms of 2-5 years.

There is a significant error margin in using yearly frequency calculations

Using the TRAX data set described above, we have calculated the error margin for using an annual liquidity calibration. Using the government bond TRAX data, we analyse the percentage of securities that had an increase or decrease of one trade per day on average (on an annualised basis) from year one to year two – a change of an average of one trade per day is significant in fixed income given the median average daily frequency of trading on an annualised basis is 1.64. **Table 1** demonstrates the results: 44% of securities in the sample universe increased or decreased in frequency of trading by at least one trade a day (average on an annualised basis). This is a significant change in trading activity from one year to the next that would not be captured in an annual calibration (the activity in the first year would apply to the second year). Further, of the 56% that did not increase/decrease by one trade a day, 64% of those securities did not trade once a day in either year 1 or year 2 of the testing period. Therefore, of the securities that actually trade at least once per day on average (and are thereby more sensitive to the time period of calibration), 68% increase or decrease in frequency of trading from one year to the next by at least one trade a day on average.

Such a large margin of error is unworkable.

Table 1: percentage of government bond securities that increased /decreased by one trade a day on average

| One trade a day or more increase/decrease from Y1 to Y2? | % of total securities in universe | % of total securities in universe adjusted for securities that trade at least once per day |
|---|--|---|
| Yes | 44% | 64% |
| No | 56% | 36% |

Source: TRAX

- **AFME recommends a monthly calibration of frequency of trading**

AFME recommends that a monthly calibration is most appropriate for fixed income instruments. As discussed above, the time period needs to be sufficiently dynamic to capture changes in trading activity but not be too volatile – we believe a monthly calibration would be the best fit for achieving this. Again, AFME acknowledges the operational challenges for implementing a more dynamic calibration; however, we stress the importance of achieving the right periodicity from an economic perspective. The liquidity and financial stability of the markets should not be sacrificed at the expense of a lack of investment in the necessary infrastructure required for the operationalisation of MiFID. We note that when transparency requirements were introduced in the US, there was a significant build out of infrastructure by US regulators to ensure a soundly working operational system.

2011 to 30 September 2013. Given that these securities were chosen at random, we can assume that this universe is proportionally representative.

In any event, we believe that there are simple solutions that would permit the right periodicity from an economic perspective. We describe our solutions in answer to **DP Questions 132 and 178**.

We believe that a monthly period is most appropriate because:

Changes in frequency of trading is much more gradual on a month to month basis and there is a 39% less margin of error compared to a yearly period

Undertaking a similar analysis to the one above on government bonds on a monthly basis rather than annually, demonstrates that a monthly calibration is more appropriate than a yearly calibration. Specifically, the analysis shows that changes in frequency of trading are far more gradual from month to month meaning that a monthly calibration would be less distortive. As a reminder, 44% of all securities (64% adjusted for instruments that trade negligibly) increased or decreased by one trade a day on average when calculated on an annual basis. However, only 5% of all securities increased or decreased by one trade a day on average from one month to the next. As such, the trading activity of a particular month can be reasonably estimated using the trading activity of the previous month.

Therefore, the margin of error is 39% less when the frequency of trading is calculated on a monthly basis rather than an annual period of calculation.

Table 2: percentage of government bond securities that increased /decreased by one trade a day on average

| One trade a day or more increase/decrease from month 1 to month 2 | % of total securities in universe |
|---|-----------------------------------|
| Yes | 5% |
| No | 95% |

Source: TRAX

Table 3: comparison of monthly and yearly testing period cliff effects for government bonds

| | Monthly | Yearly |
|---|---------|--------|
| % of securities that increased by at least one trade day (average) from one cycle of the period to the next cycle | 5% | 44% |

Source: TRAX

(i) *Minimum number of trading days is essential if the calibration period is not sufficiently dynamic*

If the calibration is sufficiently dynamic, the minimum number of trading days is not a necessary parameter. For example, the total number of trades in a month is a good estimate of the average daily turnover in a month. We would recommend for ESMA to adopt the least number of parameters necessary so as to reduce the complexity of the regime and duplicative parameters.

However, if ESMA decides on a long and distortive period, we believe that the minimum number of trading days is a critical parameter and should be adopted. However, we note that this will not avoid a large margin of error but simply mitigate some of its effects.

Block-level trades should be used rather than allocations

For the calculation of average frequency of transactions, it is essential that block-level trades are used rather than allocations. Even though matching is a very important process, it is essential that the allocations are not included in the trade frequency count. Rather, it should be the block level trades that are counted. For example, if a bank undertakes a trade of EUR 50mm notional with a client and that client allocates the EUR 50mm to 100 different funds, the trade count should be one (one trade of EUR 50mm and not 100 trades of EUR 500,000). Counting at the allocation level would be misleading and would incorrectly inflate the number of trades. It is essential that this is clarified by ESMA.

Non-price forming trades should not be included in the investment firm liquidity calculations

Many trades that investment firms undertake are not price forming trades but are trades undertaken for other reasons. For example, technical trades such as those that occur for the purposes of risk management (e.g. interaffiliate trades) are not price forming. Non-price forming trades should not be considered in the liquidity calculations. If these were to be included, the calculation of frequency of trading or ADT, it would be severely distortive, to the detriment of risk management and collateral flow.

We also recommend that primary trades are not price forming trades because at this stage everyone is a price taker. The calculations would distort and exaggerate trading activity (the bond could in practice be totally illiquid and not traded after the trade date if locked up by the buy-side).

Other examples also include securities financing transactions and trade amendments.

Further, extremely small non-price forming trades should also be scrubbed from the data set of trade count. Many of these again are technical trades, such that they are not price forming. For example, a very small trade may be an amendment to a previous trade (which had the wrong amount booked incorrectly). These small sizes are typically in the region of EUR 10,000 in size or less³. Including such trades in the calculations would be highly distortive.

The calculation of frequency of trades should be based on a centralised operational structure with clear protocols and standards in place to ensure high quality non-duplicative data is used for calibration purposes

We believe that the importance of developing an economically sound MiFID regime for fixed income outweighs the costs to development of supporting infrastructure by regulators and industry. ESMA has identified that the liquidity calibration should be based on frequency of trades and ADT, which are European-wide parameters. Such a calibration must be undertaken centrally – such a calibration cannot be undertaken at NCA or investment firm level. Further, given the liquidity-sensitive nature of fixed income instruments, we believe the maintenance of a single central list of instruments is more critical for fixed income and is unavoidable. Simply because the scale of the application of MiFID to fixed income is greater than for equities, does not justify infrastructure that is not fit for purpose. AFME strongly recommends that the regime is calibrated through a single central calibrating entity for maintaining all static and reference data as

³ This does not mean all trades below EUR 10,000 are non-price-forming

well as undertaking dynamic calibration that uses data from the entire European market. Having NCAs collecting the same data and undertaking the same calculations individually will result in an inconsistent, unworkable and highly fragmented regime. Such a fragmented regime is in direct contradiction of the objectives set out in MiFIR (Recital 2) to: *“In the context of the future European supervision architecture, the European Council of 18 and 19 June 2009 stressed the need to establish a European single rule book applicable to all financial instruments in the internal market”*. Given the inevitable operational need for a centralised calibration (based on the other proposals of ESMA for fixed income), we believe a more dynamic approach calibrated at instrument level would be operationally feasible (please see AFME’s responses to **DP Questions 132 and 178**).

FOREIGN EXCHANGE

For FX, the GFXD partially agrees with ESMA and supports Option 3 as being the most preferable option in calculating the average frequency of transactions. We suggest that it would be preferable to calculate the ‘average frequency’ using the number of transactions over a consecutive time period, the period being of sufficient time to allow the collated data to be normalized, considering disruption events or other events that cause unusual trading patterns.

The GFXD believes that throughout its drafting of Regulatory Technical Standards, ESMA should give due consideration to the application of the various requirements to instruments traded as part of a package. By a Package Transaction we mean the following (1) the Packaged Transaction has two or more components that are priced as a package with simultaneous execution of all components and (2) the execution of each component is contingent on the execution of the other components. A package is designed to provide desired risk-return characteristics effectively in the form of a single transaction with efficiencies in execution cost and reduction in risk (market and operational) achieved through concurrent execution.

Simultaneous execution of a package with a single counterparty using a single execution method alleviates the timing and mechanical risks and lowers bid/offer costs to those of the intended risk of the package. Inappropriate application of certain requirements, particularly Pre- and Post-Trade Transparency requirements and the Derivatives Trading Obligation, will jeopardise the ability of market participants to execute the entire package (primarily because exposure of an order in one transaction gives rise to the possibility of another party unrelated to the intended package trading that component transaction).

Particular consideration should be given by ESMA to whether a sufficiently broad range of venues can adequately process Package Transactions, both in terms of the execution of such transactions and the post-trade processing, even where such venues offer trading in the component instruments on a standalone basis. To date, it has proven more complex for venues and central counterparties to implement processing of Package Transactions compared to the processing of standalone transactions. The technical build required to support electronic execution beyond a limited range of Package Transactions, given the number of conceivable permutations of Packages, will be very challenging to market participants and venues alike, and could prove impossible for certain permutations.

The inability to execute packages will result in significantly increased costs and risks to market participants. These costs and risks arise primarily from three sources: (1) separately trading the components of a Packaged Transaction incurs the possibility of the market moving between executions of each component because such executions cannot be precisely time-matched, (2) there are likely to be differences in contract specifications, mode of execution, clearing/settlement workflows and relative liquidity when components of a Packaged Transaction are executed separately and/or on different venues, and (3) accessing different

sources of liquidity for the various components when traded across different venues or over-the-counter incurs additional bid/offer spreads.

The GFXD recommends that the application of the various requirements of MiFID II / MiFIR to the trading of components as a Package Transaction should be considered separately from the application of the requirements to those same instruments when traded on a standalone basis. This is particularly important for the application of the Pre- and Post-Trade Transparency requirements, and the Derivatives Trading Obligation. Generally, we recommend that each transaction comprising a package must be considered liquid in order for the package to be subject to the transparency rules or the Derivatives Trading Obligation. The presence of illiquid instruments in the package should permit the package to benefit from waivers for Pre-Trade Transparency, Deferrals for Post-Trade Transparency, and not be subject to the Derivatives Trading Obligation.

However, for the purposes of counting frequency and volumes of transactions within the test of liquidity, we recommend that ESMA adopt a much simpler approach. Where a trade arises as part of a package, each transaction should be considered on a standalone basis. Other approaches would likely be unfeasible for ESMA; for instance, in order to consider the liquidity of Package Transactions, ESMA would have to collect data on trading in each Package permutation, which would prove technically challenging if not impossible given the number of conceivable permutations.

On the understanding that ESMA, with respect to Package Transactions gives appropriate consideration to the application of Pre- and Post-Trade Transparency obligations, and the Derivatives Trading Obligation then a simplistic assessment of transaction frequency for the purposes of assessment of liquidity of the component transactions is acceptable.

<ESMA_QUESTION_103>

Q104: Do you agree with the proposed approach? If you do not agree please provide reasons. Could you provide an alternative approach?

<ESMA_QUESTION_104>

AFME Response

FIXED INCOME:

No. AFME does not agree. Whilst AFME agrees with Option 2 for bonds and SFPs, we believe that ADT should be calculated on the basis of notional rather than market value.

(i) *AVT is not meaningful for bonds and SFPs for the purposes of calibrating liquidity*

AFME agrees with ESMA that Option 2 is more appropriate for the fixed income market: for the average size to be calculated based on the total turnover over a period divided by the number of trading days in that time period (ADT).

Average value of transactions (AVT) is not meaningful for the fixed income markets as an assessment of liquidity because there is no standard market size. This is demonstrated by the average size of transactions and the standard deviations (calculated using the TRAX data⁴):

| Government bonds | EUR | Corporate bonds | EUR | Covered Bonds | EUR |
|---------------------|----------------|---------------------|---------------|---------------------|---------------|
| Average | 8,616,362 | Average | 873,784 | Average | 2,240,274 |
| Median | 1,400,000 | Median | 150,000 | Median | 500,000 |
| STD | 23,968,969 | STD | 5,376,057 | STD | 11,672,169 |
| Largest transaction | 10,248,486,633 | Largest transaction | 1,070,000,000 | Largest transaction | 1,645,050,000 |

| Surpranational | EUR | High Yield | EUR | ABS | EUR |
|---------------------|---------------|---------------------|-------------|---------------------|-------------|
| Average | 2,311,669 | Average | 365,692 | Average | 6,301,402 |
| Median | 97,000 | Median | 100,000 | Median | 2,400,000 |
| STD | 11,973,024 | STD | 1,269,505 | STD | 18,039,779 |
| Largest transaction | 3,083,736,476 | Largest transaction | 317,819,632 | Largest transaction | 911,218,415 |

Source: TRAX

⁴ AFME has undertaken testing on trade data provided by TRAX. 10,091 traded fixed income bonds were randomly chosen from six asset classes (government bonds, surpranationals, corporate bonds, high yield, covered bonds and securitisation). Trade data for these securities was tested over the period 1 October 2011 to 30 September 2013. Given that these securities were chosen at random, we can assume that this universe is proportionally representative.

For example, the average trade size for the government bond sample set is EUR 8.6mm with a very large standard deviation of \pm EUR 24mm. For the corporate bond sample set, the average trade size is EUR 800k with a standard deviation of \pm EUR 5mm.

(ii) ADT should be calculated using notional rather than notional multiplied by price

We strongly recommend that the ADT should be calculated by dividing the notional volume turnover (rather than market value) by the number of days in the period. We have outlined our reasons above in response to **CP Question 129**. Further, as for frequency of trades, we recommend for the time period to be monthly rather than yearly.

Reasons:

- Basing turnover thresholds on market value will introduce unnecessary price volatility as a factor into the calculations and thereby introduce uncertainty. For example, if the price suddenly fell from one trade to the next, the aggregate turnover would be highly distortive.
- It also introduces arbitrage opportunities for firms to price in the SI threshold.
- Instruments do not trade on a price x volume manner – the size of trades, there thereby volume, is determined on the basis of notional not price.
- Market valuation methodologies are not standardised and are highly proprietary. Using market values would create inconsistencies. These inconsistencies would be more notable in the more illiquid end of the spectrum.

(iii) The calculation of ADT should not include non-price forming trades

Many trades that investment firms undertake are not price forming trades but are trades undertaken for other reasons. For example, technical trades such as those that occur for the purposes of risk management (e.g. interaffiliate trades) are not price forming trades. Price forming trades should not be considered in the liquidity calculations. If these were to be included, the calculation of frequency of trading or ADT, it would be severely distortive, to the detriment of risk management and collateral flow.

We also recommend that primary trades are not price forming trades because at this stage everyone is a price taker. The calculations would be distort and exaggerate trading activity (the bond could in practice be totally illiquid and not traded after the trade date if locked up by the buy-side).

Other examples also include securities financing transactions and trade amendments.

(ii) The calculation of ADT should be based on a centralised operational structure with clear protocols and standards in place to ensure high quality non-duplicative data is used for calibration purposes

We believe that the importance of developing an economically sound MiFID regime for fixed income outweighs the costs to development of supporting infrastructure by regulators and industry. ESMA has identified that the liquidity calibration should be based on frequency of trades and ADT, which are European-wide parameters. Such a calibration must be undertaken centrally – such a calibration cannot be undertaken at NCA or investment firm level. Further, given the liquidity-sensitive nature of fixed income instruments, we believe the maintenance of a single central list of instruments is more critical for fixed income and is unavoidable. Simply because the scale of the application of MiFID to fixed income is greater than for equities, does not justify infrastructure that is not fit for purpose. AFME strongly recommends that the regime is calibrated through a single central calibrating entity for maintaining all static and reference data as well as undertaking dynamic calibration that uses data from the entire European market. Hav-

ing NCAs collecting the same data and undertaking the same calculations individually will result in an inconsistent, unworkable and highly fragmented regime. Such a fragmented regime is in direct contradiction of the objectives set out in MiFIR (Recital 2) to: “*In the context of the future European supervision architecture, the European Council of 18 and 19 June 2009 stressed the need to establish a European single rule book applicable to all financial instruments in the internal market*”. Given the inevitable operational need for a centralised calibration (based on the other proposals of ESMA for fixed income), we believe a more dynamic approach calibrated at instrument level would be operationally feasible (please see AFME’s responses to **DP Questions 132 and 178**).

<ESMA_QUESTION_104>

Q105: Do you agree with the proposed approach? If you do not agree please provide reasons. Could you provide an alternative approach?

<ESMA_QUESTION_105>

AFME Response

FIXED INCOME:

No. AFME does not agree.

(i) *AFME recommends Option 1 for the determination of the number of market participants*

Whilst, AFME agrees with Option 1 for capturing the number of market participants for bonds and SFPs, we note that this parameter is not as critical a measure of liquidity as frequency of trades and ADT. If ESMA decides to use number of market participants as a parameter, we agree with ESMA’s approach in that it should be used as a backstop.

(ii) *Number of market participants should be calculated using LEIs*

AFME recommends that LEIs should be used to calculate the number of market participants. With regards to categorising retail investors, we agree with ESMA that there is neither an obvious definition nor could such a definition be applied across all classes of financial instruments.

The accurate identification of counterparties is widely recognised as a critical element for enhanced systemic risk monitoring and management. AFME recommends, where possible, for counterparty identification information to be provided in the form of LEIs.

At the Cannes Summit Meeting, the G20 stated: “we support the creation of a global legal entity identifier, which uniquely identifies parties to financial transactions”. We believe that if ESMA does not mandate the use of LEIs by the national competent authorities, it will be a missed opportunity for incorporating a valuable tool for unambiguous entity identification into this important effort. Further, by not requiring the use of authoritative LEI in this project, ESMA runs the risk of making data aggregation and systemic risk analysis more difficult and less accurate.

We would like to ensure that the ESMA is aware of the true availability of LEIs. The fact is, as of April 2014, the Regulatory Oversight Committee (ROC) has endorsed 13 pre- Local Operating Units (LOUs) globally, which can issue LEIs to any entity in the world that will be accepted by the regulatory community. More than 241,000 LEIs have been issued in 178 countries by these LOUs. In terms of current usage, LEIs have been mandated for use in reporting OTC derivative transactions. The regulatory community now has the opportunity to require companies to obtain LEIs from any of these entities for use in regulatory reporting and other regulatory purposes.

In our view, ESMA has the opportunity to further the goal of creating a robust LEI system. By mandating the use of the LEI for any counterparty identified in the fixed income markets, legal



entities who have not already done so will need to obtain an LEI and ESMA will have progressed the use and scope of the global LEI system.

We believe that by the time fixed income transparency is implemented, it is likely that the global LEI system will be fully operational and will no longer be in an interim state, which is serving to support existing reporting requirements. As such, we urge ESMA to take a leadership role and mandate the use of the global LEI for the identification of counterparties within the data template requirements.

(iii) We propose for the minimum number of participants threshold to be 15 (on a monthly basis)

Based on the analysis using TRAX data⁵, we recommend a backstop number of market participant threshold of 15. Using the TRAX data and the AFME liquidity parameters below in response to **Question 112** (frequency and ADT), we have plotted charts for corporate bonds and government bonds showing the number of ISINs falling within each number of market participant range based on monthly data (based over the 24 month period – each ISIN could get counted a maximum 24 times over the period).

⁵ AFME has undertaken testing on trade data provided by TRAX. 10,091 traded fixed income bonds were randomly chosen from six asset classes (government bonds, supranationals, corporate bonds, high yield, covered bonds and securitisation). Trade data for these securities was tested over the period 1 October 2011 to 30 September 2013. Given that these securities were chosen at random, we can assume that this universe is proportionally representative.

The “liquid” graphs demonstrate those securities that have sufficiently large turnovers and frequencies such that they appear liquid but are not due to a small number of market participants (i.e. the bottom tail ends of the “liquid” graphs). The “illiquid” graphs act as references for the number of market participants that illiquid instruments typically have.

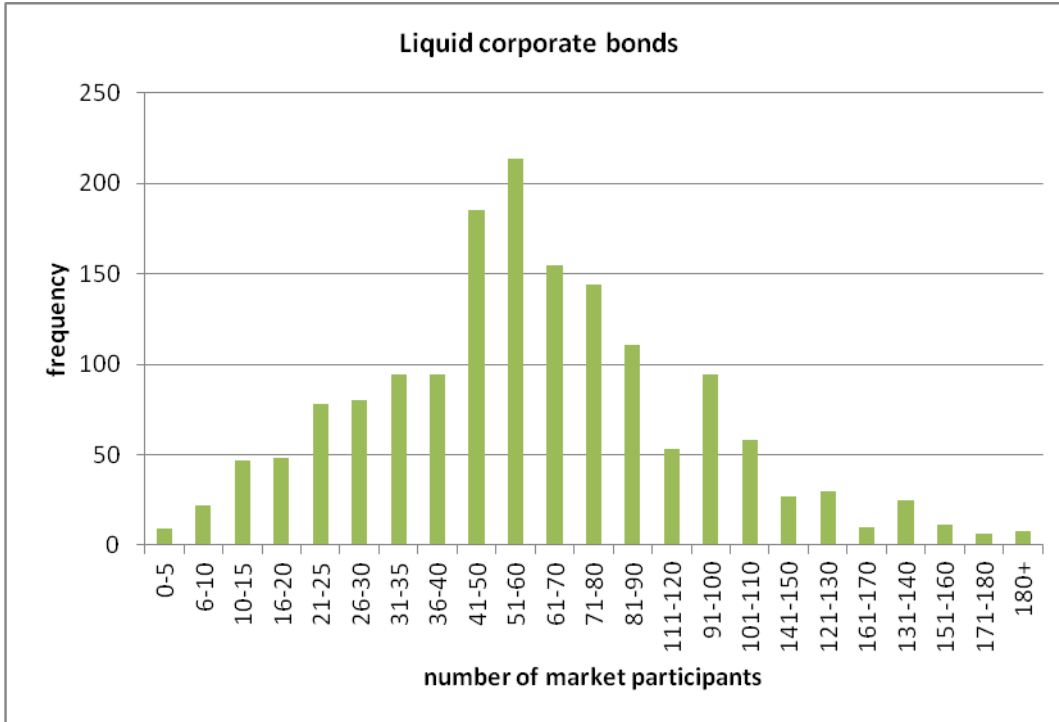

Source: TRAX

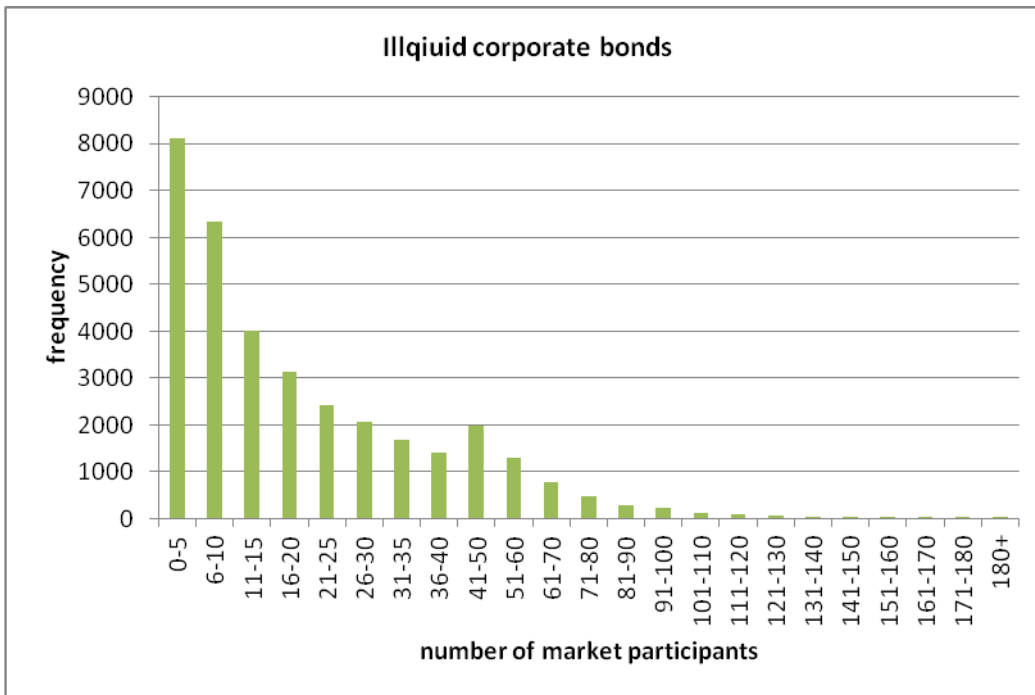

Source: TRAX

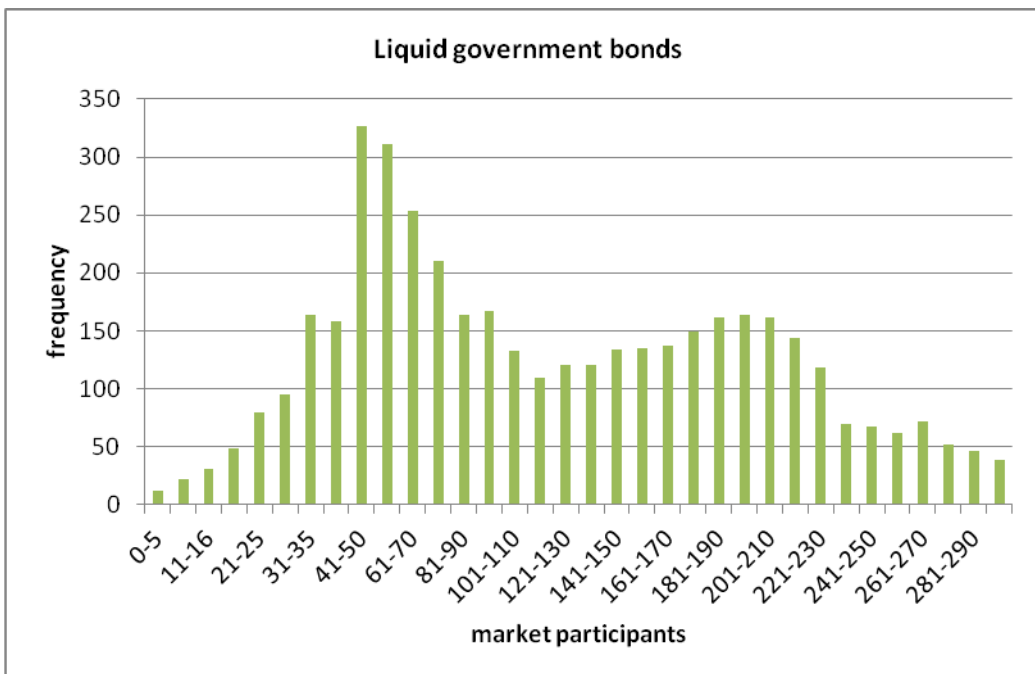

Source: TRAX

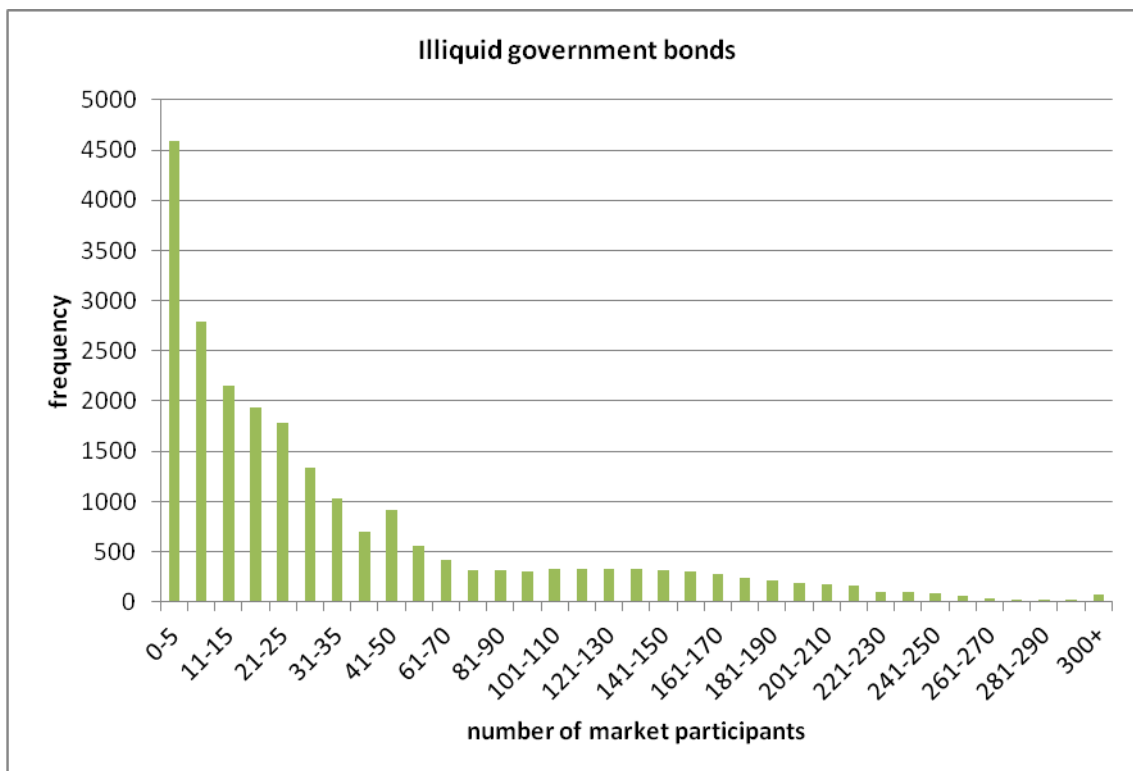

Source: TRAX

To determine the appropriate threshold for the minimum number of market participants, we observed the “tail end” of the charts and observed where the troughs of the liquid chart overlapped with the troughs of the illiquid charts the greatest. We propose that the appropriate level is 15. Applying a threshold of 15 to corporate bonds reduced the number of corporates qualifying as liquid by approximately 15%. Applying a threshold of 15 to government bonds reduced the number of government bonds qualifying as liquid by approximately 5% - by number of securities in any given month.

(iv) For the calculation of the number a market participants, we propose that ESMA collect data from trading venues.

No single venue can determine the number of different market participants for a given instrument. Therefore, a centralised calibration is necessary to ensure the calculations are achievable (as described above in **DP Questions 103 and 104**) and to it ensure the data can be collected and consolidated in a non-duplicative manner.

If a particular instrument has no market participants on a venue, this clearly indicates that an instrument is not liquid and should, thus, inform the calibration.

FOREIGN EXCHANGE

For FX, the GFXD partially supports Option 2 as being the most preferable method in assessing data related to market participants and we consider number of liquidity providers on a trading venue to be a good reflection of the market’s ability to provide liquidity in a particular financial instrument. The FX market does not typically require contractual arrangements to provide liquidity, but we would suggest the number of market participants who are authorized to respond

to (not request) an RFQ or voice request (thereby providing liquidity) is a good proxy. This number could easily be obtained from the venues.

<ESMA_QUESTION_105>

Q106: Do you agree with the proposed approach? If you do not agree please provide reasons. Could you provide an alternative approach?

<ESMA_QUESTION_106>

AFME Response

FIXED INCOME

No. AFME does not agree.

(i) *The parameter should only apply to instruments that substantially trade on lit order book systems*

We strongly agree that the bid-ask spreads should only be used on lit order book trading systems. Further, the parameter should only be applied to instruments that trade on an order book on a substantial basis. In all other circumstances, bid-ask spreads are not reliable and readily available measures of liquidity.

(ii) *End-of-day spreads should not be used – intraday snapshots of spreads linked to volume is more meaningful*

With regards to bid-ask spreads used as measures of liquidity for instruments traded on order book, we would not recommend the use of average bid-ask spread calculated over a certain period that are based on end-of-day spreads because:

- End-of-day spreads may not be representative of the spread incurred by market members during the course of the trading session;
- End-of-day spreads may not be reliable as they could be fed by participants that have no intentions to trade; and
- Measuring a spread irrespective of the type, and even more importantly, of the size of the quotes, can be misleading, as a narrow spread on a very limited size should in no instance be considered as evidence of liquidity for institutional market participants.

We consider that the following alternatives could be considered:

- Venues could be asked to publish average spreads (based on actual trades) over each trading session (based on randomly determined snapshots)
- To be meaningful, spreads need to be related to available sizes. Relative sizes could be measured for (i) the average value trade and (ii) the size specific for the given instrument.

FOREIGN EXCHANGE

For FX, the GFXD partially agrees with the proposed ESMA approach and considers that there are certain characteristics of the FX market that should additionally be considered as these are different to some of the other derivative asset classes.

Due to the size of the FX market, the proliferation of trading venues and number of market participants, the market itself operates 24 hours a day, for 5.5 days in the week. Whilst it could be observed that the liquidity of certain currencies changes as their specific sovereign markets



are open, it is generally considered that for liquid products, market participants seek an executable price at any time 24hours/day for 5.5 days of the week.

To accommodate this, most market makers operate global risk management positions, whilst many trading venues or single dealer electronic platforms operate on a 24 hour basis. It is therefore not relevant to state for the FX market that an end-of-day bid/ask spread can be used in the calculation of liquidity as the concept of end-of-day does not exist.

The FX market primarily operates on a request-for-quote (RFQ) basis and therefore we believe that it is inappropriate to consider for the FX market the text in #27.i, page 121 of the Discussion Paper.

ESMA's proposal fails to take into account both that liquidity at end of day may be unrepresentative of liquidity throughout the day, and that many markets do not have a defined "end of day" concept. Instead, we recommend that ESMA obtain spread data from venues that is based on repeated polling of market interests at intervals (e.g. hourly) throughout the day.

We strongly recommend that ESMA should not ignore those days where spread data is not available or incomplete. Instead, ESMA should take these into account. The total or partial absence of spread data may be a good indication that the market in a particular instrument is not liquid.

We would also agree with ESMA and suggest that consideration needs to be taken to accommodate transactional variances, such as the instrument class (e.g. FX v Equity), notional size and maturity, as these will ultimately impact the bid-ask spread.

<ESMA_QUESTION_106>

Q107: Should different thresholds be applied for different (classes of) financial instruments? Please provide proposals and reasons.

<ESMA_QUESTION_107>

FIXED INCOME

No. AFME does not agree.

We do agree that there should be a different approach for bonds/SFPs compared with derivatives. However, there should not be different thresholds across bond/SFP asset classes.

FOREIGN EXCHANGE

For FX, the GFXD has performed additional analysis on the data collated in 2012 as part of the Financial Markets Lawyers Group (FMLG) analysis as part of The Foreign Exchange Committee and Financial Markets Lawyers Group Request for Interpretative Relief Regarding the Obligation to Provide Pre-Trade Mid-Market Quote under the CFTCs part 23 obligations. This data was based on a represented executable pricing data for select currencies (in order of market share EUR, AUD, MXN, TRY, TWD, ILS) supplied by major FX banks who participate on the FMLG based on ranking in the Bank for International Settlements (BIS) 31 CCYs compared to publicly available data published the same time on Bloomberg for the month of November 2012. Results for these currencies are illustrated in the tables below.

As a point of reference, according to the BIS Triennial Central Bank Survey Foreign exchange turnover in April 2013: preliminary global results report (<http://www.bis.org/publ/rpfx13fx.pdf>), the market share for the top 5 BIS currencies is: USD is (87%), EUR (33.4%), JPY (23%), GBP (11.8%) and AUD (8.6%).

In order to make the Bid-Ask spread more tangible, they have been converted into a dollar

amount (per million USD of traded notional). The GFXD believes that by taking the Bid-Ask spread and converting it to a USD amount is more meaningful as this directly measures the economic impact of the Bid-Ask spreads.

Conclusions:

- **Bid-Ask Spreads** in USD terms: the dollar value of the Bid-Ask spread for the instrument, per million dollars notional and provides an indication of liquidity in the market. For instance, a 2Y ILS Forwards has a Bid-Ask of over USD 5,000, while a EUR/USD 6M forward has a Bid-Ask of less than USD 100 (50 times less). One of them is clearly very liquid, the other is not. This data is illustrated in Table 3.
- **The ratio of Bid-Ask spread to mid**, $[(Ask-Bid) / [(Ask+Bid)/2]]$: In FX, unlike some other asset classes, the relative size of the mid price compared to the Bid-Ask spread can distort the ratio and therefore provide an inaccurate representation of liquidity. This is illustrated in Table 4, we can see that by using this approach, USD/MXN appears to be more liquid than EUR/USD, due to the fact that the USD/MXN mid-point is circa 16 times larger than the EUR/USD mid, which is not reflected in the relative size of the Bid-Ask spreads. Consequently, the ratio proposed by ESMA is not a valid determination of relative liquidity in the FX market.

The GFXD recommended indicator of liquidity would therefore be to use a US dollar equivalent of the bid-ask.

Table 3: Results for the USD equivalent of the Bid-Ask spread, as defined in the previous section, both for forwards and options, and for 6m, 1Y and 2Y tenors.

| Forwards | | | | | | |
|-----------------------|---------|----------|----------|----------|----------|----------|
| | EUR/USD | AUD/USD | USD/MXN | USD/TRY | USD/TWD | USD/ILS |
| 6M | | | | | | |
| Bid-Ask Spread | \$ 84 | \$ 99 | \$ 373 | \$ 1,432 | \$ 846 | \$ 768 |
| 1Y | | | | | | |
| Bid-Ask Spread | \$ 214 | \$ 328 | \$ 397 | \$ 2,479 | \$ 1,003 | \$ 1,537 |
| 2Y | | | | | | |
| Bid-Ask Spread | \$ 741 | \$ 1,145 | \$ 2,139 | \$ 5,063 | \$ 1,850 | \$ 5,869 |

| Options | | | | | | |
|-----------------------|----------|----------|-----------|----------|-----------|----------|
| | EUR/USD | AUD/USD | USD/MXN | USD/TRY | USD/TWD | USD/ILS |
| 6M | | | | | | |
| Bid-Ask Spread | \$ 1,753 | \$ 1,798 | \$ 3,758 | \$ 5,420 | \$ 5,316 | \$ 3,673 |
| 1Y | | | | | | |
| Bid-Ask Spread | \$ 2,437 | \$ 2,558 | \$ 5,180 | \$ 4,530 | \$ 7,201 | \$ 5,166 |
| 2Y | | | | | | |
| Bid-Ask Spread | \$ 4,610 | \$ 4,896 | \$ 12,417 | \$ 9,218 | \$ 12,638 | \$ 6,537 |

Table 4: the ratio of Bid-Ask spread to mid as defined in the previous section, both for forwards and options, and for 6m, 1Y and 2Y tenors.

| Ratio of Bid-Ask spread to mid of Forwards | | | | | | |
|--|---------|---------|---------|---------|---------|---------|
| Tenor/Currency Pair | EUR/USD | AUD/USD | USD/MXN | USD/TRY | USD/TWD | USD/ILS |
| 6M | 4% | 1% | 2% | 6% | 10% | 13% |
| 1Y | 5% | 1% | 1% | 5% | 7% | 14% |
| 2Y | 8% | 2% | 3% | 5% | 9% | 27% |

| Ratio of Bid-Ask spread to mid of Options | | | | | | |
|---|---------|---------|---------|---------|---------|---------|
| Tenor/Currency Pair | EUR/USD | AUD/USD | USD/MXN | USD/TRY | USD/TWD | USD/ILS |
| 6M | 4% | 4% | 7% | 12% | 24% | 9% |
| 1Y | 3% | 3% | 6% | 10% | 21% | 8% |
| 2Y | 4% | 4% | 8% | 7% | 21% | 11% |

<ESMA_QUESTION_107>

Q108: Do you have any proposals for appropriate spread thresholds? Please provide figures and reasons.

<ESMA_QUESTION_108>

AFME Response

FIXED INCOME:

AFME would be happy to work with ESMA to advise on this in more detail once ESMA has received the data required to consider what the appropriate spread thresholds should be.

FOREIGN EXCHANGE

For FX, the GFXD has performed additional analysis on the data collated in 2012 as part of the Financial Markets Lawyers Group (FMLG) analysis as part of The Foreign Exchange Committee and Financial Markets Lawyers Group Request for

Interpretative Relief Regarding the Obligation to Provide Pre-Trade Mid-Market Quote under the CFTCs part 23 obligations. This data was based on a represented executable pricing data for select currencies supplied by major FX banks who participate on the FMLG based on ranking in the Bank for International Settlements (BIS) 31 CCYs (in order of market share EUR, AUD, MXN, TRY, TWD, ILS) compared to publicly available data published the same time on Bloomberg for the month of November 2012. As a point of reference, according to the BIS Triennial Central Bank Survey Foreign exchange turnover in April 2013: preliminary global results report (<http://www.bis.org/publ/rpfx13fx.pdf>), the market share for the top 5 BIS currencies is: USD is (87%), EUR (33.4%), JPY (23%), GBP (11.8%) and AUD (8.6%). In summary, the GFXD compared the banks' quotes for both options and forwards against publicly available Bloomberg data at the same moment for the month of November of 2012, comparing the size of deviations of bank mids from Bloomberg's to quote spreads. In order to make these differences more tangible, we take each bank's mid-point (arithmetic mean of bid and ask), and compare it with Bloomberg's mid-point. The difference between the two quotes is turned into a dollar amount (per million USD of traded notional). The GFXD believes that by taking the difference between the 2 quotes and converting it to a USD amount is more meaningful because:

- This directly measures the economic impact of the bid-ask spreads

- For currency-pairs where the spreads are usually wide (e.g. USD/TRY), the impact of only using the difference between the 2 quotes produces a result which is counter to market expectations when compared between highly liquid and illiquid pairs. For example, looking at Table 1, at the data for the 6 month forwards, the data suggests a ratio of 9% for USD/TRY v a ratio of 29% for EUR/USD, implying that a 6 month forward in USD/TRY is more liquid than a 6 month forward in EUR/USD, which is obviously not the case. When this is converted to a USD amount the results are as expected

Conclusions:

- Q1: Mid-Quote Spreads in USD terms: the dollar value of the average distance (spread) of submitted mid-prices, per million dollars notional.
- Q2: Bid-Ask Spreads in USD terms: the dollar value of the Bid-Ask spread for the instrument, per million dollars notional.
- Q3: The ratio of Q1 to Q2, that is, the relative importance of the Mid-Quote spreads, as compared to Bid-Ask spreads.
- Q4: The ratio of Bid-Ask spread to mid, that is, the relative importance of the Bid-Ask spread to the price itself. This is the relative spread $(Ask-Bid) / [(Ask+Bid)/2]$.

Having looked at all of these numbers for the existing data population, we conclude that Q1 and Q2 provide the most useful measure in order to categorize the different instruments and currencies:

- Q1 provides an indication of tightness in the mid price submissions. For instance, mid prices for EUR/USD 6M forwards are within USD25 per 1mm notional, so any source for a mid price will be sufficient, there is no need to ask the seller for a mid-price
- Q2 provides an indication of liquidity in the market. For instance, a 2Y ILS Forwards has a Bid-Ask of over USD 5,000, while a EUR/USD 6M forward has a Bid-Ask of less than USD 100 (50 times less). One of them is clearly very liquid, the other is not

Table 1: Results for Q1, Q2 and Q3, as defined in the previous section, both for forwards and options, and for 6m, 1Y and 2Y tenors.

| Forwards | | | | | | |
|--------------------------|----------------|----------------|----------------|----------------|----------------|----------------|
| 6M | EUR/USD | AUD/USD | USD/MXN | USD/TRY | USD/TWD | USD/ILS |
| Mid Quotes Spread | \$ 24 | \$ 42 | \$ 111 | \$ 127 | \$ 314 | \$ 407 |
| Bid-Ask Spread | \$ 84 | \$ 99 | \$ 373 | \$ 1,432 | \$ 846 | \$ 768 |
| Ratio | 29% | 43% | 30% | 9% | 37% | 53% |
| 1Y | EUR/USD | AUD/USD | USD/MXN | USD/TRY | USD/TWD | USD/ILS |
| Mid Quotes Spread | \$ 46 | \$ 98 | \$ 190 | \$ 282 | \$ 366 | \$ 407 |
| Bid-Ask Spread | \$ 214 | \$ 328 | \$ 397 | \$ 2,479 | \$ 1,003 | \$ 1,537 |
| Ratio | 21% | 30% | 48% | 11% | 37% | 27% |
| 2Y | EUR/USD | AUD/USD | USD/MXN | USD/TRY | USD/TWD | USD/ILS |
| Mid Quotes Spread | \$ 183 | \$ 170 | \$ 545 | \$ 745 | \$ 1,186 | \$ 2,496 |
| Bid-Ask Spread | \$ 741 | \$ 1,145 | \$ 2,139 | \$ 5,063 | \$ 1,850 | \$ 5,869 |
| Ratio | 25% | 15% | 25% | 15% | 64% | 43% |

| Options | | | | | | |
|--------------------------|----------------|----------------|----------------|----------------|----------------|----------------|
| 6M | EUR/USD | AUD/USD | USD/MXN | USD/TRY | USD/TWD | USD/ILS |
| Mid Quotes Spread | \$ 537 | \$ 393 | \$ 613 | \$ 818 | \$ 1,060 | \$ 681 |
| Bid-Ask Spread | \$ 1,753 | \$ 1,798 | \$ 3,758 | \$ 5,420 | \$ 5,316 | \$ 3,673 |
| Ratio | 31% | 22% | 16% | 15% | 20% | 19% |
| 1Y | EUR/USD | AUD/USD | USD/MXN | USD/TRY | USD/TWD | USD/ILS |
| Mid Quotes Spread | \$ 753 | \$ 520 | \$ 894 | \$ 853 | \$ 1,423 | \$ 1,060 |
| Bid-Ask Spread | \$ 2,437 | \$ 2,558 | \$ 5,180 | \$ 4,530 | \$ 7,201 | \$ 5,166 |
| Ratio | 31% | 20% | 17% | 19% | 20% | 21% |
| 2Y | EUR/USD | AUD/USD | USD/MXN | USD/TRY | USD/TWD | USD/ILS |
| Mid Quotes Spread | \$ 1,043 | \$ 1,154 | \$ 3,771 | \$ 1,897 | \$ 3,167 | \$ 1,556 |
| Bid-Ask Spread | \$ 4,610 | \$ 4,896 | \$ 12,417 | \$ 9,218 | \$ 12,638 | \$ 6,537 |
| Ratio | 23% | 24% | 30% | 21% | 25% | 24% |

Table 2: the relative Bid-Ask Spread, or Q3 in the Summary Section above

| Average Spread to Mid Ratio of Forwards | | | | | | |
|---|----------------|----------------|----------------|----------------|----------------|----------------|
| Tenor/Currency Pair | EUR/USD | AUD/USD | USD/MXN | USD/TRY | USD/TWD | USD/ILS |
| 6M | 4% | 1% | 2% | 6% | 10% | 13% |
| 1Y | 5% | 1% | 1% | 5% | 7% | 14% |
| 2Y | 8% | 2% | 3% | 5% | 9% | 27% |

| Average Spread to Mid Ratio of Options | | | | | | |
|--|----------------|----------------|----------------|----------------|----------------|----------------|
| Tenor/Currency Pair | EUR/USD | AUD/USD | USD/MXN | USD/TRY | USD/TWD | USD/ILS |
| 6M | 4% | 4% | 7% | 12% | 24% | 9% |
| 1Y | 3% | 3% | 6% | 10% | 21% | 8% |
| 2Y | 4% | 4% | 8% | 7% | 21% | 11% |

<ESMA_QUESTION_108>

Q109: How could the data necessary for computing the average spreads be obtained?

<ESMA_QUESTION_109>

AFME Response

FIXED INCOME

AFME recommends that ESMA obtain data on spreads from trading venues.

FOREIGN EXCHANGE

For FX, the GFXD proposes that data should be obtained from trading venues.

<ESMA_QUESTION_109>

Q110: Do you agree with the proposed approach? If you do not agree please provide reasons for your answer. Could you provide an alternative approach?

<ESMA_QUESTION_110>

AFME Response

FIXED INCOME

No. AFME does not agree.

(i) AFME proposes Option 2 for bonds and SFPs.

AFME believes that it is essential for trading frequency and ADT to be considered with equal weighting. We suggest that an instrument needs to meet both the trading frequency and ADT threshold and one of either number of market participants or bid-ask spread to be deemed as liquid.

If a particular instrument has no market participants on a venue or spread information, this clearly indicates that an instrument is not liquid and should, thus, inform the calibration. An instrument with more liquidity should not be subject to more thresholds (i.e. fall within a more limited MiFID regime) than less liquid instruments.

(ii) Average frequency of trades and ADT are essential parameters – an instrument should meet the thresholds of both these parameters before it can be considered liquid

For fixed income, as mentioned above, the main two criteria that are relevant are total frequency of trades and ADT. With regard to these parameters, both need to be weighted equally. Plotting total frequency of transactions against total monthly volume (i.e. ADT * number of days in a month) using trade data provided by TRAX for government bonds and corporate bonds, it is clear that there is no correlation between the two parameters. As such, both need to be considered with equal weighting.

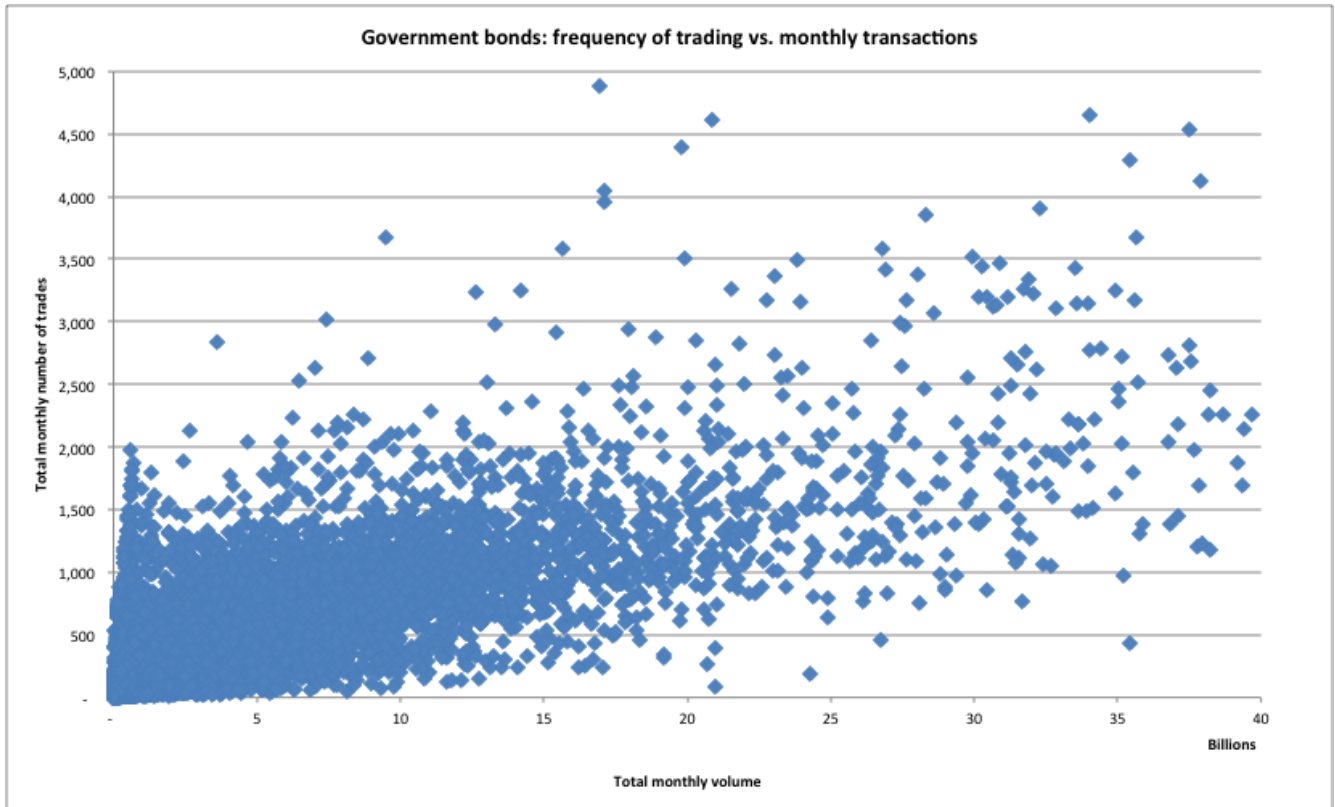

Source: TRAX

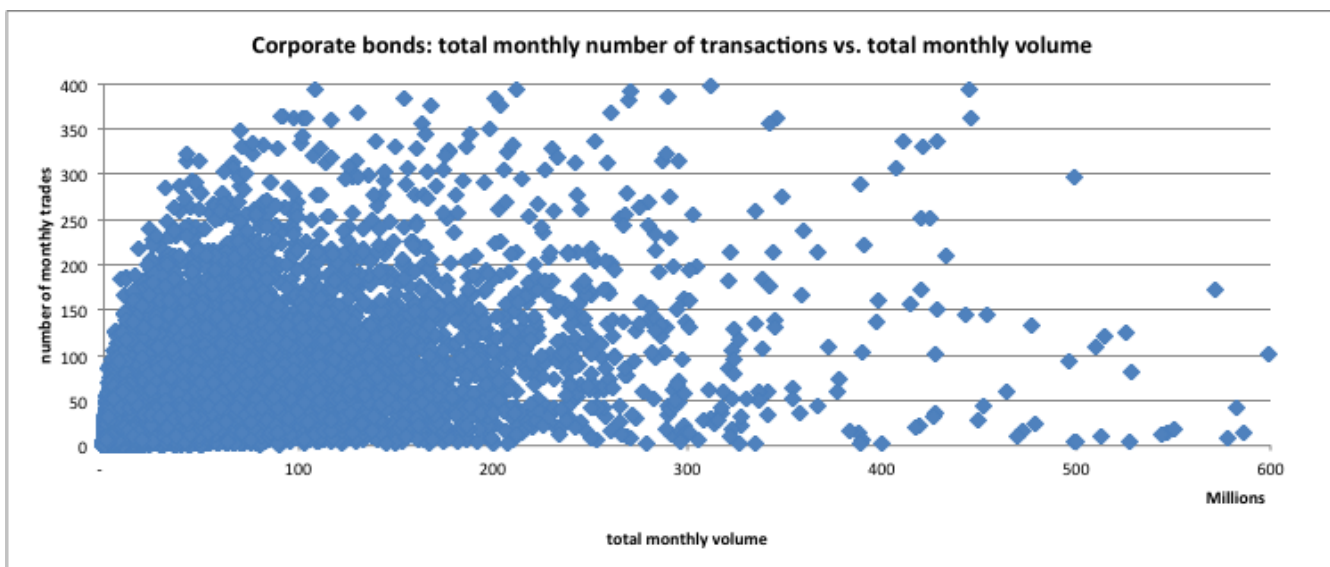

Source: TRAX

FOREIGN EXCHANGE

For FX, the GFXD agrees with ESMA and that Option 1 is most relevant in helping to determine if a financial instrument is liquid and agrees that for FX all 4 factors are generally available.

<ESMA_QUESTION_110>

Q111: Overall, could you think of an alternative approach on how to assess whether a market is liquid bearing in mind the various elements of the liquid market definition in MiFIR?

<ESMA_QUESTION_111>

AFME Response

FIXED INCOME:

AFME does not propose an alternative approach

FOREIGN EXCHANGE

For FX, the GFXD does not have an alternative approach to defining liquidity.

<ESMA_QUESTION_111>

Q112: Which is your preferred scenario or which combination of thresholds would you propose for defining a liquid market for bonds or for a sub-category of bonds (sovereign, corporate, covered, convertible, etc.)? Please provide reasons for your answer.

<ESMA_QUESTION_112>

AFME Response

FIXED INCOME:

(i) *AFME does not agree with any of ESMA's scenarios for bonds and SFPs*

Generally, we do not agree with any of the scenarios proposed by ESMA. We believe that all the thresholds are set too low and do not act as a genuine division between liquid markets and non-liquid markets. A security that does not trade on every trading day cannot be deemed liquid. Further, a threshold of either EUR 100k or EUR 1mm ADT cannot be appropriate, given that the median trade size of government bonds is EUR 1.4mm and corporate bonds is EUR 150k (greater than the proposed thresholds).

(ii) Setting thresholds based on the number of instruments falling within the liquid category is not appropriate

We do not believe that using the number of bonds falling within the liquid category to set the thresholds is appropriate. The nature of the fixed income markets is that the majority of instruments do not trade. As such, the determination of instruments that are liquid should be based on those instruments that do trade. Maximising the number of instruments in the liquid category is arbitrary, is not calibrated for the actual market and could have significant unintended consequences. In fact, it is important that the thresholds are sensitive to changes in market dynamics and that at times of market stress, the number of instruments qualifying as liquid should decrease and in times of market boom, the number of instruments deemed liquid should increase.

We note that do not agree with ESMA counting bonds that haven't traded in the calculation of percentage of bonds captured as liquid – we believe that it is distortive to consider thresholds in this manner. As mentioned in the analysis in paragraph 72 of the Discussion Paper, roughly 55% of bonds did not trade at all. As such, even if the threshold was set at the absolute minimum (e.g. one trade a year at EUR 1mm), ESMA could only achieve a maximum of 45% of liquid bonds. Therefore, the percentage of bonds that are liquid are only relative to the 45%. As such, we recommend a meaningful analysis should be based on percentage of bonds that are actually traded.

(iii) AFME recommends option 1 with regards to determining the threshold

With regards to determining the liquidity thresholds, we recommend ESMA adopt Option 1: “professional expert judgement provided by both ESMA’s dedicated working groups as well as stakeholders and external experts...” (i.e. a policy-based approach). We do not believe that Option 2 is appropriate, which would look to optimise the percentage of volume and the percentage of transactions that are deemed liquid. However, rather than taking a broad inclusive approach, we urge ESMA to consider the purpose of the liquidity thresholds. Specifically, where an instrument does not have a liquid market, it qualifies for a waiver under pre trade transparency for venues, is exempt from the pre trade transparency rules for SI and is eligible for post trade transparency deferrals. Therefore, ESMA should consider where the calibration of the liquidity threshold would be harmful to the market were it to misclassify instruments as liquid. Further, an important aspect of a liquidity calibration is for it to be sensitive to stressed market circumstances. As explained above, one of the positive qualities of a liquidity calibration is that in stressed market circumstances, less of the market is deemed liquid allowing easier market recovery and in times of market boom, more instruments will be deemed liquid and subject to greater levels of transparency.

(iv) ESMA can optimise the levels of transparency by introducing real-time post transparency for small trades for illiquid instruments rather than setting the liquidity threshold inappropriately low

We note that ESMA has set low thresholds, we understand, as a means to optimise the level of transparency that the MiFID II regime will introduce. We believe that it is inappropriate for the thresholds to be set unduly low purely for the purpose of optimising transparency levels. If illiquid instruments are deemed liquid, they will be subject to the same pre and post trade trans-

parency regimes as liquid instruments. As noted above, if an instrument does not trade every day in the whole market, it cannot be liquid. We believe that there will be unintended consequences if the thresholds are set in this way, in that it will become too expensive for market makers to commit capital to facilitate trades in illiquid instruments – this will create procyclical effects (illiquid instruments will become more illiquid) and costs to investors/borrowing costs for issuers will increase.

Another means of optimising post trade transparency, is to look to where the concentration of trades are. We believe that the liquidity threshold and the size threshold of LIS and SSTI cannot be considered in isolation. We note that the ESMA scenarios capture a significant amount of trade volume but the proportion of transactions is significantly less (on average 22% less). The reason for this is that a significant proportion of trade flow is in illiquid instruments in small sizes. The majority of trade flow is not in larger size trades. For example, in government bonds, approximately 16% of trades take place in sizes of less than EUR 1mm in instruments that trade less than 9 times a day. Conversely, trades in sizes greater than EUR 20mm in government bonds that trade more than 20 times per day only make up approximately 6% of trade flow. Further, for corporate bonds, approximately 60%⁶ of trade flow takes place in sizes of less than EUR 500k in bonds that trade less than three times per day but less than 0.01% of trade flow is generated from large trades of greater than EUR 10mm in instruments that trade approximately 10 times a day.

As such, we recommend that instead of inappropriately low thresholds for liquidity (that capture illiquid instruments), small trade sizes for instruments (with issue sizes equal to or greater than EUR 500mm) without a liquid market to be subject to real time publication for the purposes for post trade transparency. As such, transparency will be optimised without compromising the non-liquid markets. For example, the ESMA scenarios achieve 35.26%-75.40% “liquid” transparency levels for all bonds; however, the AFME proposed liquidity levels, which includes small illiquid trades for EUR 500mm-5bn, achieves 72-78% of transactions subject to the “liquid” regime.

The diagram below illustrates AFME’s proposal:

| <i>EUR >=5bn</i> | | | |
|----------------------------------|------------------|----------------------------|------------------|
| <i>Super-liquid & Liquid</i> | | <i>Illiquid</i> | |
| <i>>LIS</i> | <i>Deferral</i> | <i>>SSTI</i> | <i>Deferral</i> |
| <i>SSTI-LIS</i> | <i>Deferral</i> | | |
| <i><SSTI (EUR 1mm)</i> | <i>Real time</i> | <i><=SSTI (EUR 1mm)</i> | <i>Real time</i> |

| <i>EUR 500mm – 5bn</i> | |
|------------------------|-----------------|
| <i>Liquid</i> | <i>Illiquid</i> |

⁶ From October 2011 to September 2013

| | | | |
|----------------------------|------------------|-----------------------------|------------------|
| >LIS | Deferral | >SSTI | Deferral |
| SSTI-LIS | Deferral | | |
| <SSTI (EUR 500k) | Real time | <=SSTI (EUR 500k) | Real time |

Instruments with EUR <=500mm issue sizes should be deemed illiquid and, as such, should not be subject to the “liquid” regime.

(v) ESMA should introduce subcategories based on issue size category – less than or equal to EUR 500mm (<=500mm), greater than EUR 500mm but less than EUR 5bn (500mm – 5bn) and equal to or greater than EUR 5bn (>=5bn)

Rather than creating sub categories of liquidity based on asset class, which is complex and unnecessary, we propose sub categories based on issue size⁷. This is because:

- The parameters being used to determine liquidity are a function of the depth of volume available. Therefore, it is essential to consider broad issue size categories. For example, the turnover of a EUR 15bn bond cannot be compared to a EUR 500mm bond: a turnover of 100mm a month is small for the EUR 15bn bond but is significant (20% of the issue size) for the EUR 500mm bond.
- There is a broad correlation between liquidity and issue size in that bonds with larger issue sizes tend to have greater liquidity than bonds with smaller issue sizes. The chart below compares the monthly frequency of trades between traded government (using the TRAX data for October 2012) bonds of different issue sizes - it shows the percentage of bonds in the sample set for a given issue size category that trades greater than or equal to 80 trades a month and less than 80 trades a month. We use a threshold of 80 trades a month because we propose that this is the appropriate threshold for determining a liquid instrument based on the frequency of trades for instruments with issue sizes EUR 500mm – 5bn.

⁷ Issue size rather than outstanding is appropriate because some bonds amortise (e.g. ABS)

Chart 1: comparison of monthly frequency of trading for government bonds in October 2012

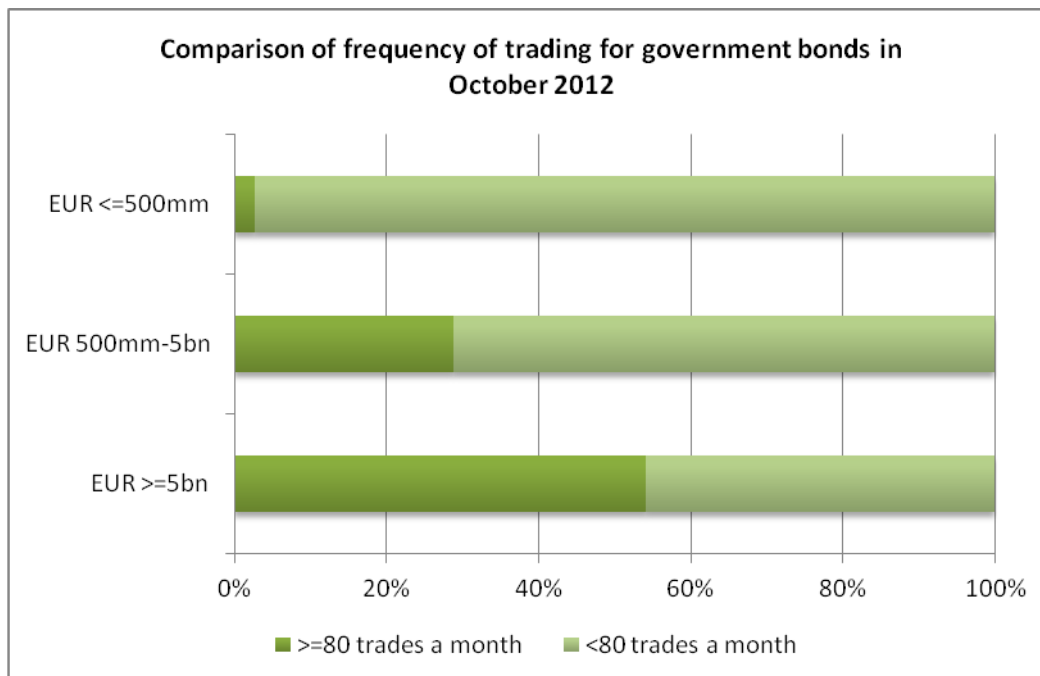

Source: TRAX

- AFME does not agree with asset class sub categories within fixed income cash bonds. Two bonds with the same issue size trading in the same manner should be treated equally. Further, not all bonds within an asset class behave in the same way. For example, some small sovereigns are liquid but more comparable to corporates than larger sovereign bonds.

We propose three issue size sub categories: EUR <500mm, EUR 500mm-5bn and EUR >5bn. Most government bonds (approximately 50%) would fall within the EUR >5bn category (see table). Approximately, 66% of corporate bonds fall within the 500mm-5bn category. The complete analysis is provided below (using TRAX data).

Government bonds

| Issue size (EUR) | |
|--------------------|---------|
| Average | 9.92bn |
| Median | 5.00bn |
| Standard deviation | 11.98bn |

| Issue size category (EUR) | Distribution (%) |
|---------------------------|------------------|
| | |



| | |
|-----------|-------|
| >5bn | 49.8% |
| 5bn-500mm | 28.2% |
| <500mm | 22.0% |

Supranationals

| Issue size (EUR) | |
|--------------------|--------|
| Average | 804mm |
| Median | 227mm |
| Standard deviation | 1.30bn |

| Issue size category (EUR) | Distribution (%) |
|---------------------------|------------------|
| >5bn | 1.3% |
| 5bn-500mm | 35.5% |
| <500mm | 63.1% |

Corporate bonds

| Issue size (EUR) | |
|--------------------|-------|
| Average | 870mm |
| Median | 721mm |
| Standard deviation | 734mm |

| Issue size category (EUR) | Distribution (%) |
|---------------------------|------------------|
| >5bn | 0.20% |
| 5bn-500mm | 75.5% |
| <500mm | 24.3% |

High yield

| Issue size (EUR) |
|------------------|
|------------------|



| | |
|--------------------|-------|
| Average | 422mm |
| Median | 345mm |
| Standard deviation | 299mm |

| Issue size category (EUR) | Distribution (%) |
|---------------------------|------------------|
| >5bn | 0% |
| 5bn-500mm | 29.3% |
| <500mm | 70.7% |

Covered bonds

| Issue size (EUR) | |
|--------------------|--------|
| Average | 965mm |
| Median | 1.00bn |
| Standard deviation | 839mm |

| Issue size category (EUR) | Distribution (%) |
|---------------------------|------------------|
| >5bn | 0.14% |
| 5bn-500mm | 65.7% |
| <500mm | 34.2% |

ABS

| Issue size (EUR) | |
|--------------------|--------|
| Average | 282mm |
| Median | 53.3mm |
| Standard deviation | 1.16bn |

| Issue size category (EUR) | Distribution (%) |
|---------------------------|------------------|
|---------------------------|------------------|

| | |
|-----------|-------|
| >5bn | 0.26% |
| 5bn-500mm | 15.1% |
| <500mm | 84.7% |

(vi) Bonds and SFPs with small issue sizes (less than or equal to EUR 500mm) should be deemed illiquid

We recommend that the smallest issues that do not trade and should not be subject to unnecessary liquidity thresholding. The type of securities that would fall into this category includes non-benchmark high yield bonds and mezzanine tranches of securitisations. We recommend that the threshold is EUR 500mm.

This is evidenced by the TRAX trade data, which demonstrates that instruments falling within the small issue size category predominantly trade highly infrequently and that a significantly smaller proportion of transactions/volumes is as a result of trading of small issue size instruments (relative to the proportion of securities in the category).

Government bonds

| Issuance category | size | Number transactions (%) of | Volume traded (%) | Percentage securities in the test |
|-------------------|------|----------------------------|-------------------|-----------------------------------|
| >5bn | | 88.24% | 97.43% | 49.8% |
| 500mm – 5bn | | 10.64% | 2.33% | 28.2% |
| <500mm | | 1.11% | 0.23% | 22.0% |

Corporate bonds

| Issuance category | size | Number transactions (%) of | Volume traded (%) | Percentage securities in the test |
|-------------------|------|----------------------------|-------------------|-----------------------------------|
| >5bn | | 0.64% | 0.32% | 0.20% |
| 500mm – 5bn | | 88.02% | 92.44% | 75.5% |
| <500mm | | 11.33% | 7.24% | 24.3% |

High yield

| Issuance category | size | Number transactions (%) of | Volume traded (%) | Percentage securities in the test |
|-------------------|------|----------------------------|-------------------|-----------------------------------|
|-------------------|------|----------------------------|-------------------|-----------------------------------|

| | | | |
|-------------|--------|--------|-------|
| >5bn | 0% | 0% | 0% |
| 500mm – 5bn | 71.70% | 66.44% | 29.3% |
| <500mm | 28.30% | 33.56% | 70.7% |

Source: TRAX

Further, the illiquid nature of small issue sizes is illustrated in the chart below. Using October 2012 as an example, out of 713 corporate bonds in the TRAX data set that were less than EUR 500mm in size, only 7 securities traded four times or more a day (a threshold of 80 trades a month was used based on AFME’s proposed frequency of trading thresholds below).

Chart 2: daily frequency of trading for corporate bonds with issue sizes <500mm in October 2012

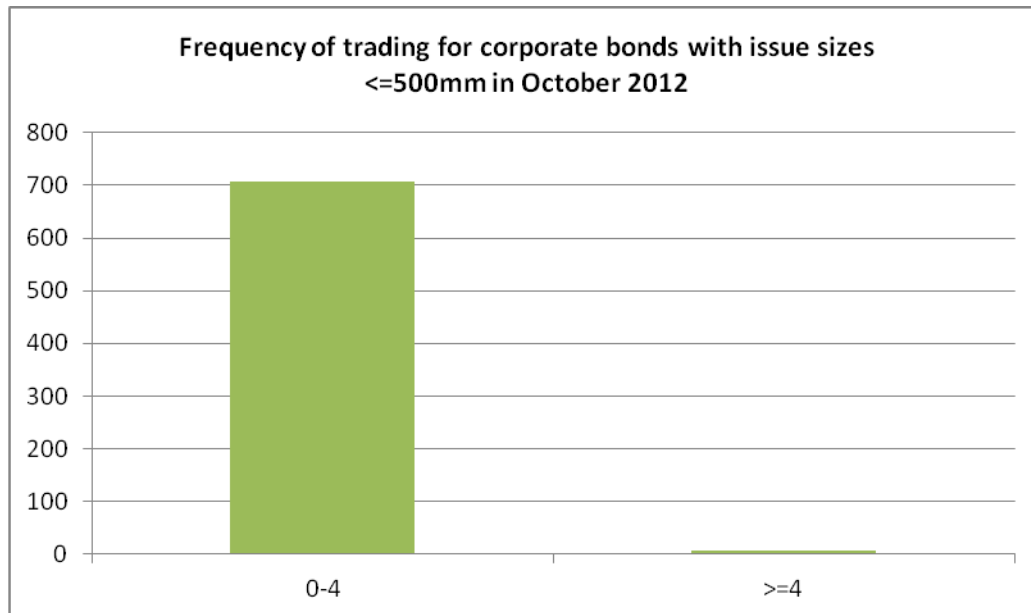

Source: TRAX

(vii) Privately placed bonds should be out of scope of the MiFID transparency regime

Privately placed bonds are bespoke by their nature and, as such, do not trade on the secondary markets. As such, ESMA should expressly provide that these instruments are out of scope. The Ferber report published on the 27 March by the European Parliament indicates that such transactions were not intended to fall within the remit of the regime. Specifically, recital 12 in the Ferber report provided that: “financial instruments that....are bespoke in their design would be outside the scope of the transparency obligations”.

(viii) We recommend a third super-liquid category for bonds and SFPs with issue sizes equal to or greater than EUR 5bn.

Further, we recommend that there should be an additional super-liquid category rather than only two categories: liquid and illiquid. A super-liquid category is necessary to optimise transparency but minimise adverse impacts to instruments that are relatively less liquid (by being able to set lower thresholds for the size deferrals/waivers for those instruments without compromising greater transparency for super-liquid instruments). At the super-liquid end of the spectrum, larger sizes can be published in real time without exposing market markers to undue risk.

We recommend that if the “liquid” threshold is set appropriately, a super-liquid category is not necessary for instruments with issue sizes between EUR 500mm to EUR 5bn. Chart 1 demonstrates that there is a greater number of liquid instruments in the large issue size category (and thereby a greater range of liquid instruments) compared to mid issue size category. Therefore, there is no need to introduce a greater granularity of liquidity for instruments in the EUR 500mm to 5bn category.

(ix) AFME’s proposed liquidity categories and thresholds

Below contains AFME’s proposed thresholds. We believe they achieve similar levels of transparency that ESMA is aiming to achieve without being unduly low such that there would be adverse impacts to the markets. We have used the TRAX data to test our thresholds.

Thresholds for >5bn issue sizes

| Issue size category >5bn | |
|--|-----------------------------------|
| Super-liquid | |
| At least x trades during a monthly period | 500 (equivalent to 6000 annually) |
| Average daily volume (20 days in a month) EUR | 500mm |
| Liquid | |
| At least x trades during a monthly period | 200 (equivalent to 2400 annually) |
| Average daily volume (20 days in a month) EUR | 250mm |

| Government bonds | ESMA scenario results | |
|--|--|------------------------------|
| Percentage of traded bonds (in sample) >5bn issue size captured as liquid and superliquid for government bonds | 22% (year 1 test period) 17.5% (year 2 test period) | 13.2% - 30.7% ⁸ - |
| Percentage of traded bonds (in sample) >5bn issue size captured as superliquid | 9.6% (year 1 test period) 6.5% (year 2 test period) | n/a |

⁸ Adjusted to traded bonds (taking 55% as not traded) – thereby using a 20/9 multiplier

| | | |
|---|--|-------------------------|
| Percentage of volume qualified as liquid and superliquid | 71.72% (year 1 test period) 67.84% (year 2 test period) | 83.15% – 93.92% |
| Percentage of volume qualified as superliquid | 47.95% (year 1 test period) 40.56% (year 2 test period) | n/a |
| Percentage of transactions qualified as liquid and superliquid | 56.31% (year 1 test period) 55.60% (year 2 test period) | 81.81% - 93.47% |
| Percentage of transactions qualified as superliquid | 34.65% (year 1 test period) 28.75% (year 2 test period) | n/a |
| Percentage of volume if <1mm trades from illiquid category included (for the purposes of greater post trade transparency) | 72.21% (year 1 test period) 68.47% (year 2 test period) | c.f. 83.15% – 93.92% |
| Percentage of transactions if <1mm from illiquid category included (for the purposes of greater post trade transparency) | 72.45% (year 1 test period) 78.35% (year 2 test period) | c.f. 81.81% - 93.47% |

Source: TRAX

The declining trend from year 1 and year 2 can be explained by the change in composition of the sample set (i.e. instruments are maturing). Only government bond analysis has been presented for the >5bn universe because those bonds make up the largest part of the universe.

Thresholds for 500mm-5bn issue sizes

| Issue size category 5bn-500mm | |
|--|---|
| Liquid | |
| At least x trades during a monthly period | 80 trades (equivalent to 960 trades annually) |
| Average daily volume (20 days in a month) EUR | 5mm |

| Corporate bonds | | ESMA scenario results |
|--|-----|------------------------------|
| Percentage of traded bonds (in sample) 500mm-5bn issue size captured as liquid | TBD | 2.06% - 10.45% ⁹ |

⁹ Adjusted to traded bonds (taking 55% as not traded) – thereby using a 20/9 multiplier

| | | |
|--|--|-------------------------|
| Percentage of volume qualified as liquid for 500mm-5bn | 8.64% (year 1 test period) 16.94% (year 2 test period) | 62.90% - 86.67% |
| Percentage of transactions qualified as liquid | 6.90% (year 1 test period) 18.06% (year 2 test period) | 35.26% - 75.40% |
| Percentage of volume if <500k trades from illiquid category included (for the purposes of greater post trade transparency) | 17.56% (year 1 test period) 14.08% (year 2 test period) | c.f. 62.90% - 86.67% |
| Percentage of transactions if <500k from illiquid category included (for the purposes of greater post trade transparency) | 77.27% (year 1 test period) 70.12% (year 2 test period) | c.f. 35.26% - 75.40% |

Source: TRAX¹⁰

(x) *Centralised calibration is essential*

We believe that the importance of developing an economically sound MiFID regime for fixed income outweighs the costs to develop supporting infrastructure by regulators and industry. ESMA has identified that the liquidity calibration should be based on frequency of trades and ADT, which are European-wide parameters. Such a calibration must be undertaken centrally – such a calibration cannot be undertaken at NCA or investment firm level. Further, given the liquidity-sensitive nature of fixed income instruments, we believe the maintenance of a single central list of instruments is more critical for fixed income and is unavoidable. Simply because the scale of the application of MiFID to fixed income is greater than for equities, does not justify infrastructure that is not fit for purpose. AFME strongly recommends that the regime is calibrated through a single central calibrating entity for maintaining all static and reference data as well as undertaking dynamic calibration that uses data from the entire European market. Having NCAs collecting the same data and undertaking the same calculations individually will result in an inconsistent, unworkable and highly fragmented regime. Such a fragmented regime is in direct contradiction of the objectives set out in MiFIR (Recital 2) to: *“In the context of the future European supervision architecture, the European Council of 18 and 19 June 2009 stressed the need to establish a European single rule book applicable to all financial instruments in the internal market”*. Given the inevitable operational need for a centralised calibration (based on the other proposals of ESMA for fixed income), we believe a more dynamic approach calibrated at instrument level would be operationally feasible (please see AFME’s responses to **DP Questions 132 and 178**).

¹⁰ AFME has undertaken testing on trade data provided by TRAX. 10,091 traded fixed income bonds were randomly chosen from six asset classes (government bonds, supranationals, corporate bonds, high yield, covered bonds and securitisation). Trade data for these securities was tested over the period 1 October 2011 to 30 September 2013. Given that these securities were chosen at random, we can assume that this universe is proportionally representative.

(xi) *The components of package trades should be counted separately for the purposes of determining the frequency of trades in a given instrument and for liquidity thresholding*

When drafting the RTS, ESMA should give due consideration to the application of the various requirements to instruments traded as part of a package. By a package transaction we mean the following (1) the package has two or more components that are priced as a package with simultaneous execution of all components and (2) the execution of each component is contingent on the execution of the other components (“**Package Transaction**”). A package is designed to provide desired risk-return characteristics effectively in the form of a single transaction with efficiencies in execution cost and reduction in risk (market and operational) achieved through concurrent execution.

Simultaneous execution of a package with a single counterparty using a single execution method alleviates the timing and mechanical risks and lowers bid/offer costs to those of the intended risk of the package. Inappropriate application of certain requirements, particularly pre and post trade transparency requirements, will jeopardise the ability of market participants to execute the entire package (primarily because exposure of an order in one transaction gives rise to the possibility of another party unrelated to the intended package trading that component transaction).

Particular consideration should be given by ESMA to whether a sufficiently broad range of venues can adequately process Package Transactions, both in terms of the execution of such transactions and the post-trade processing, even where such venues offer trading in the component instruments on a standalone basis. To date, it has proven more complex for venues and central counterparties to implement processing of Package Transactions compared to the processing of standalone transactions. The technical build required to support electronic execution beyond a limited range of Package Transactions, given the number of conceivable permutations of Packages, will be very challenging to market participants and venues alike, and could prove impossible for certain permutations.

Inability to execute packages will result in significantly increased costs and risks to market participants. These costs and risks arise primarily from three sources: (1) separately trading the components of a Packaged Transaction incurs the possibility of the market moving between executions of each component because such executions cannot be precisely time-matched, (2) there are likely to be differences in contract specifications, mode of execution, clearing/settlement workflows and relative liquidity when components of a Packaged Transaction are executed separately and/or on different venues, and (3) accessing different sources of liquidity for the various components when traded across different venues or over-the-counter incurs additional bid/offer spreads.

The processing of Package Transactions into central clearing can, with insufficient flexibility of processing, be a source of heightened risk. For example, where scenarios such as the acceptance of one or more components of the Package combined with the rejection from clearing of other components can expose the parties to those transactions to significantly increased market risk.

In general, we recommend that the application of the various requirements of MiFID II / MiFIR to the trading of components as a Package Transaction should be considered separately from the application of the requirements to those same instruments when traded on a standalone basis. This is particularly important for the application of the pre and post trade transparency requirements. Generally, we recommend that each transaction comprising a package must be considered liquid in order for the package to be subject to the transparency rules. The presence of illiquid instruments in the package should permit the package to benefit from waivers for pre-trade transparency and deferrals for post trade transparency.

However, for the purposes of counting frequency and volumes of transactions within the test of

liquidity, we recommend that ESMA adopt a much simpler approach. Where a trade arises as part of a package, each transaction should be considered on a standalone basis. As a practical example, where a 5 year Interest Rate Swap (IRS) and a 10 year IRS are traded within the same Package Transaction, these should be considered as two distinct trades, alongside other 5 year and 10 year IRS, for the purposes of assessing liquidity. Other approaches would likely be unfeasible for ESMA; for instance, in order to consider the liquidity of Package Transactions, ESMA would have to collect data on trading in each Package permutation, which would prove technically challenging if not impossible given the number of conceivable permutations.

As long as ESMA gives appropriate consideration to the application of pre and post trade transparency to packages, a simplistic assessment of transaction frequency for the purposes of assessment of liquidity of the component transactions is acceptable.

<ESMA_QUESTION_112>

Q113: Should the concept of liquid market be applied to financial instruments (IBIA) or to classes of financial instruments (COFIA)? Would be appropriate to apply IBIA for certain asset classes and COFIA to other asset classes? Please provide reasons for your answers

<ESMA_QUESTION_113>

AFME Response

FIXED INCOME

AFME recommends that for fixed income bonds and SFPs for the Instrument-by-Instrument Approach (IBIA) to be used.

We do not believe that the Classes of Financial Instrument Approach (COFIA) is appropriate for bonds and SFP. The IBIA approach would apply by assessing the universe of financial instruments against the relevant thresholds. We do believe it is appropriate for an IBIA approach to be used for bonds and SFPs and for a different approach to be applied to other products such as derivatives. As per AFME's response to **DP Question 100**, we recommend that securitised derivatives should also be assessed for liquidity using an IBIA approach (although they have structured pay off schedules according to the underlying derivative, they have more in common with bonds than derivatives, they have unique identifiers and they are quoted and settled like bonds).

i. The COFIA approach is not appropriate for bonds and SFPs

The COFIA approach not appropriate for cash bonds for the following reasons:

- ***The concept of inherent liquidity characteristics for fixed income is not meaningful***

ESMA explains that under the COFIA approach, securities would be divided into granular groups that would, according to the available empirical evidence, be considered as good explanatory features of liquidity. A necessary prerequisite for applying this approach is the proper grouping/segmentation of financial instruments into homogenous and relevant classes.

We stress that with regards to bonds, there are no inherent features that are good explanatory features of liquidity. The fixed income markets are highly heterogeneous and there is no common thread of features that determines the liquidity of the instrument. Liquidity is driven by complex fundamental economic factors and not the structures of the instruments. We recommend that liquidity can only be measured by parameters that observe the behaviour of the instrument (e.g. frequency of trading). Physical features can neither be used to predict the "inherent" liquidity nor categorise instruments into groups that behave in a similar way in terms of



liquidity. There are a couple of exceptions, such as instruments with small issue sizes, which are discussed above.

ESMA proposes that classes should be made sufficiently homogenous in order to mitigate the risk of imposing requirements on certain instruments within the class for which would be unsuitable. This is not appropriate for fixed income cash bonds. The heterogeneous nature of fixed income, in that instruments with “similar” features cannot be grouped together in such a way that the instruments will inherently have the same liquidity behaviour, is demonstrated in the analysis below (using TRAX data¹¹ - October 2012). The analysis demonstrates that the majority of instruments in all classes are illiquid and that, by using the COFIA approach, the treatment of any “class” as liquid would be inappropriate (the threshold of 80 trades a month was used to determine liquidity based on AFME’s proposal in answer to **DP Question 112**). The only class that was definitively liquid in the test sample only had one instrument in it (i.e. senior, >=EUR 5bn issue size, listed, 3-5 year term and a residual maturity of 5-20%), which in effect is the IBIA approach.

¹¹ AFME has undertaken testing on trade data provided by TRAX. 10,091 traded fixed income bonds were randomly chosen from six asset classes (government bonds, supranationals, corporate bonds, high yield, covered bonds and securitisation). Trade data for these securities was tested over the period 1 October 2011 to 30 September 2013. Given that these securities were chosen at random, we can assume that this universe is proportionally representative.

Senior vs subordinated

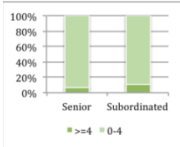

Senior vs subordinated vs issue size

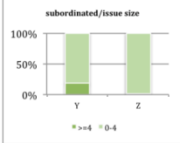
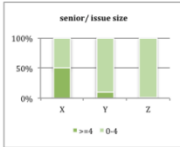

Senior vs subordinated vs issue size vs listing

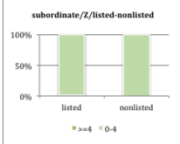
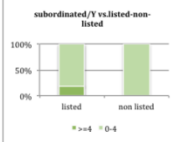
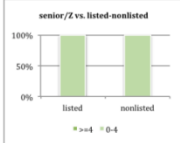
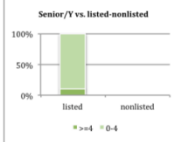
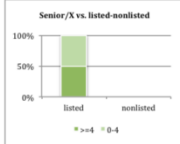

Senior vs subordinated vs issue size vs term

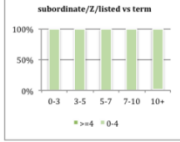
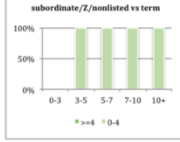
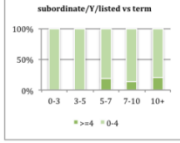
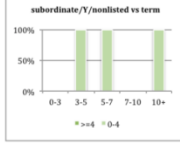
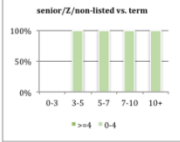
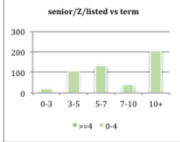
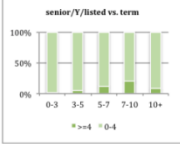
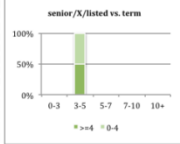

Senior vs subordinated vs issue size vs term vs residual maturity

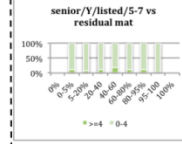
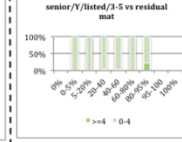
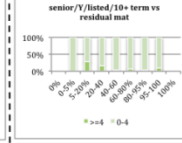
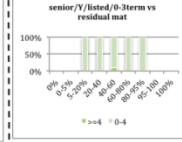
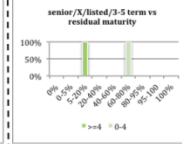

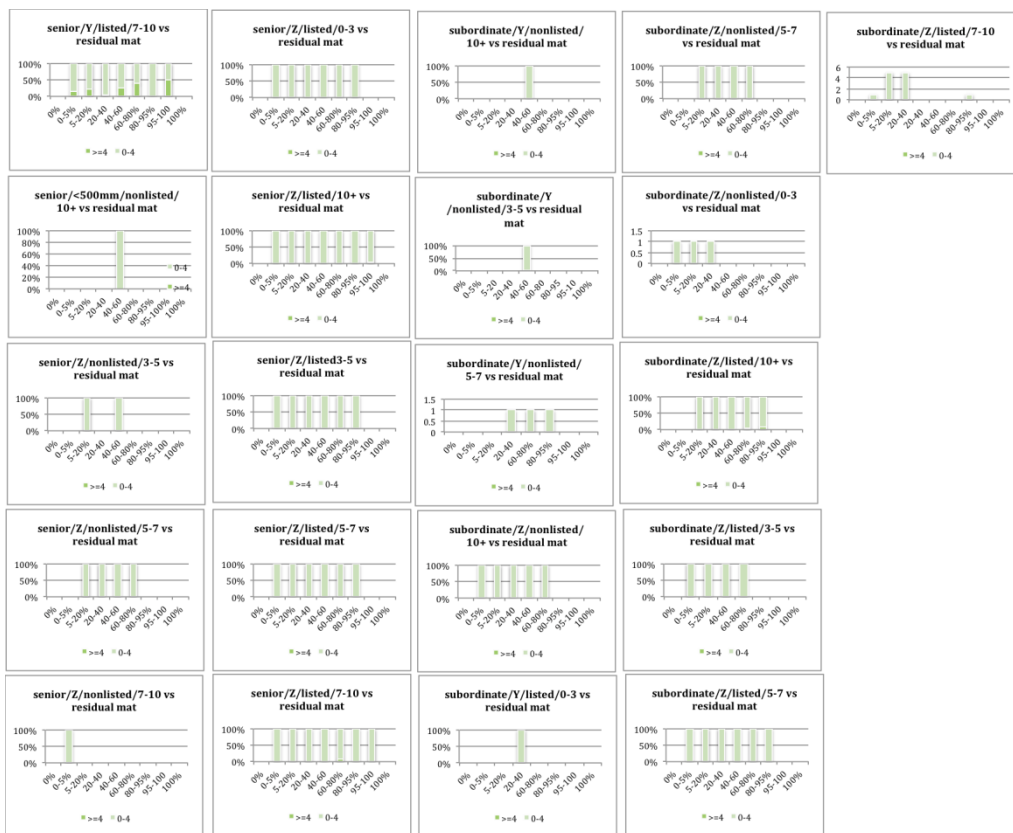

Source: TRAX

- ***The re-categorisation of instruments is linked to features that are not correlated to liquidity***

A key theoretical feature of the COFIA approach would be that since the categorisation of the instruments is based on features that are linked to liquidity, a less periodic recalibration is necessary. Specifically, since the features of an instrument is being linked to liquidity, then for the COFIA model to work, when the liquidity of an instrument changes, a feature should also change (if liquidity is linked to the features of the instruments) and that instrument would be reclassified into a category that is reflective of its new liquidity. The only structural feature that changes over time listed on page 133 of the Discussion Paper is residual maturity. Therefore, for the reclassification of COFIA to work, residual maturity needs to be correlated to liquidity. The graph below **Chart 1** demonstrates that residual maturity is not directly correlated to liquidity of the instrument (the product of frequency of trades and volume turnover vs. the residual maturity). Therefore, bonds would not be reclassified appropriately as liquidity in the instrument changes over time.

Chart 1: monthly frequency X volume turnover vs. residual maturity for corporate bonds

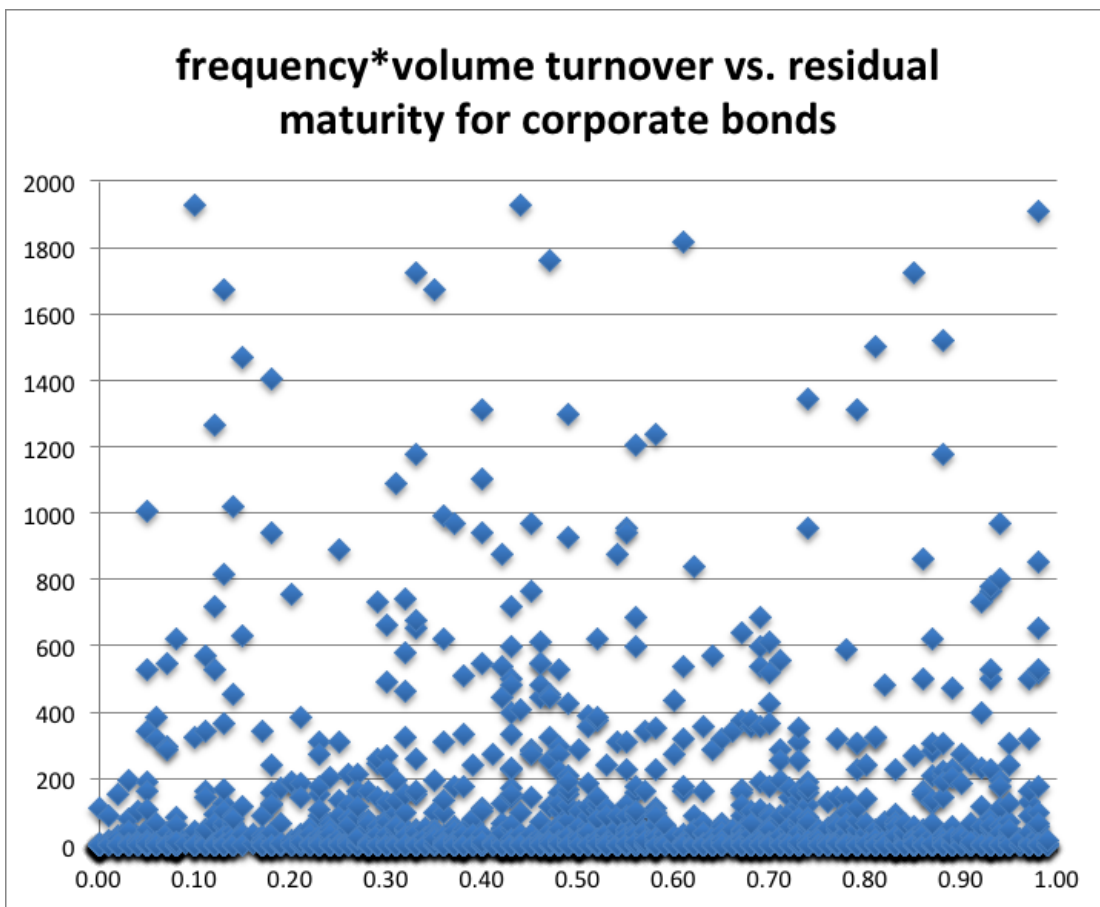

Source: TRAX - 1 October 2011 – September 2013

- ***The calculation of the liquidity is highly complex operationally (more so than IBIA)***

ESMA notes that one of the preferable features of the COFIA in comparison to the IBIA approach is that it is more operationally simple than an ISIN-by-ISIN approach. We recommend that the COFIA approach is not any more operationally simple than the ISIN-by-ISIN approach and can in fact be more complex.

ESMA notes on paragraph 44 of the Discussion Paper that the liquidity of the subcategories under the COFIA approach needs to be reassessed periodically. To calculate the liquidity of a class, the ADT and the frequency of trades (and other parameters) need to be assessed at individual ISIN level (within the category) and then the data will need to be further manipulated to produce the liquidity of the class. As such, there is a second additional layer of complexity in the calculation of the liquidity of the subcategory. Further, this will need to be done on a periodic basis, adding additional complexity.

A further element of complexity with regards to the COFIA approach will be that bonds will constantly be moving in and out of different subcategories (i.e. there will be dynamic reclassification of securities). The dynamic reclassification of bonds is a key feature of the COFIA (the theory that the dynamic nature of liquidity is captured through the features of bonds). This will mean that bonds will be moving into different categories over time. This dynamic movement over time will need to be monitored at instrument level, to ensure that the market knows the classification of the bond that they are trading (and as such the regime that applies under MiFID). This is highly operationally complex and very volatile. One of the main concerns ESMA

has with the IBIA approach is the introduction of volatility. We highlight that the COFIA approach introduces far more volatility.

Further, as bonds will be moving into different sub-categories dynamically, periodic assessment of the liquidity of the sub-classes will need to be fairly dynamic (there will always be a different composition of bonds). As such, the liquidity of the sub-classes will need to be calibrated dynamically using the complex methodology above.

ii. *The IBIA approach is most appropriate for bonds and structured finance products*

The IBIA approach is most appropriate for fixed income cash bonds for the following reasons (in addition to the points regarding why the COFIA approach is not appropriate):

- ***The fixed income cash bond market is highly heterogeneous***
- ***The IBIA approach is more precise***
- ***The IBIA approach can be implemented in a simple manner***

AFME recommends that for the IBIA approach to be workable, an appropriate simple operational structure with supporting infrastructure needs to be introduced. Our recommendations are in answer to **DP Questions 132 and 178**. With this operational structure, we believe that the IBIA approach can be introduced without a great deal of complexity.

We believe that the importance of developing an economically sound MiFID regime for fixed income outweighs the costs to develop supporting infrastructure by regulators and industry. ESMA has identified that the liquidity calibration should be based on frequency of trades and ADT, which are European-wide parameters. In-on-of-itself, such a calibration would need to be undertaken centrally – such a calibration cannot be undertaken at NCA or investment firm level. Further, given the liquidity-sensitive nature of fixed income instruments, we believe the maintenance of a single central list of instruments is more critical for fixed income and is unavoidable. Simply because the scale of the application of MiFID to fixed income is greater than for equities, does not justify infrastructure that is not fit for purpose. AFME strongly recommends that the regime is calibrated through a single central calibrating entity for maintaining all static and reference data as well as undertaking dynamic calibration that uses data from the entire European market. Having NCAs collecting the same data and undertaking the same calculations individually will result in an inconsistent, unworkable and highly fragmented regime. Such a fragmented regime is in direct contradiction of the objectives set out in MiFIR (Recital 2) to: “*In the context of the future European supervision architecture, the European Council of 18 and 19 June 2009 stressed the need to establish a European single rule book applicable to all financial instruments in the internal market*”. Given the inevitable operational need for a centralised calibration (based on the other proposals of ESMA for fixed income), we believe a more dynamic approach calibrated at instrument level would be operationally feasible.

2. *IBIA can be applied to bonds and SFP, whereas a different approach can be applied to other instruments*

We do not see any problems with an IBIA approach being applied to bonds and SFPs and a COFIA to other asset classes. Consistency, where possible, should be optimised; however, we recommend for deviation in approach where necessary to do so.

3. *The treatment of new issues should be based on their issue size*

One of the major concerns that ESMA has with the IBIA approach is the treatment of new issues. We propose that as long as the periodic assessment of the liquidity of the instruments is sufficiently dynamic, new issues should be treated as liquid instruments in the first instance. The

instruments may drop out of the liquid category in the next period (i.e. if the period is monthly, the instrument may drop out of the liquid category in the second month).

However, this rule would not apply to instruments of issue size of less or equal to EUR 750mm. As discussed above, small issues are generally illiquid, and therefore, they should not be treated as liquid in the first month of issue. In fact, issue sizes up to EUR 750mm are typically illiquid when first issued. The chart below demonstrates that corporate issues below EUR 750mm are on average illiquid compared to new issues greater than EUR 750mm. In answer to **DP Question 112**, we suggest that the appropriate liquidity threshold for frequency of trades is 80 trades a month (i.e. 20 trades a week). The chart clearly demonstrates that less than 750mm issues trade on average less than the 20 trades a week from issuance to week 8, whereas issues greater than 750mm on average have liquidities greater than 20 trades a week until approximately week 5. Issues less than or equal to EUR 750mm correspond to approximately 5% of investment grade corporate bonds (in our sample set).

Chart 2: average weekly number of trades for corporate bonds vs. the number of weeks from issuance

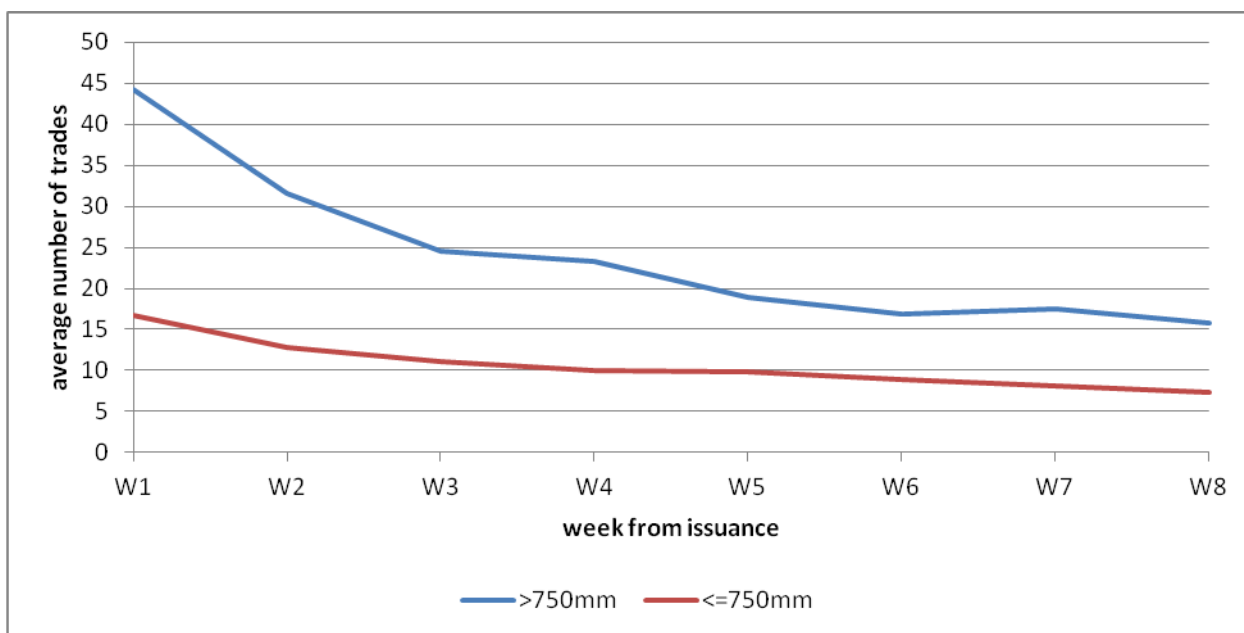

Source: TRAX¹²

Further, we note that it is essential that the regime adopted by ESMA with regards to new issues does not create perverse incentives for issuers to arbitrage the liquidity calibrations. Specifically, a liquidity calibration encourages issuers to issue their bonds at a particular time of the month because their instrument would be more likely to be classified as illiquid. Therefore, we suggest that for the second month after issue, the liquidity status of the bond is based on an ADT and frequency calculated based on the number of days since issue rather than a 20 day month. For

¹² AFME has undertaken testing on trade data provided by TRAX. 10,091 traded fixed income bonds were randomly chosen from six asset classes (government bonds, supranationals, corporate bonds, high yield, covered bonds and securitisation). Trade data for these securities was tested over the period 1 October 2011 to 30 September 2013. Given that these securities were chosen at random, we can assume that this universe is proportionally representative.

example, if a bond was issued on the first day of the last week of the month and it traded 10 times that week with a total volume of EUR 50mm, the ADT of the bond should not be EUR 2.5mm (50/20) but rather EUR 10mm (50/5). Likewise, the frequency should not be 10 but rather adjusted to 40 (10 x 4 (weeks)).

We note that issuers could avoid the requirements by adding on additional volume to the security through a tap after the issuance date. To resolve this, we recommend that if there is a tap within the first month of issuance, then the issuance clock (in terms of calibration) will reset at the date of the tap. If a tap is undertaken at any time during the life of a bond and it takes the bond into a new issue size category, the bond should be assessed according to the new issue size category in the next calibration period.

<ESMA_QUESTION_113>

Q114: Do you have any (alternative) proposals how to take the ‘range of market conditions and the life-cycle’ of (classes of) financial instruments into account - other than the periodic reviews described in the sections periodic review of the liquidity threshold and periodic assessment of the liquidity of the instrument class, above?

<ESMA_QUESTION_114>

AFME Response

FIXED INCOME

No. AFME does not have any alternative proposals for bonds and SFPs

FOREIGN EXCHANGE

For FX, the GFXD suggests that any periodic review exercises are consistently applied across all regulatory parameters that require assessment, such as liquidity measures and large in scale thresholds. Such a consistent approach will allow for a suitable quantity of data to be collated, preferably from the trade repositories, and that the data is complete and representative in nature. In-line with the assessment of other thresholds, the GFXD agrees that an assessment every 2 years would be sufficient.

The GFXD believes that a cyclical 2 year assessment of market data collated from the trade repositories will include transactions executed over a wide range of market conditions (liquidity spikes, default events, change in currency specific trading patterns), as well as enabling a suitable period for all market participants to improve the quality of the data they are reporting to the trade repositories.

If such an approach is adopted, then the GFXD also believes that there needs to exist mechanisms where market participants can submit requests to ESMA (or their local National Competent Authority) asking for the re-assessment of the liquidity of a specific financial instrument. It is likely that the liquidity profile of a specific currency will change during the 2 year process (for instance due to a change in trading patterns), which whilst not triggering a suspension event, could result in a requirement to re-assess the liquidity of a specific financial instrument.

The GFXD also believes that the converse should apply, and if an instrument becomes more liquid, then the same rationale should apply, and that instrument should be re-evaluated before having its liquidity categorization updated from illiquid to liquid.

We also consider that a suitable migration period should be built into the liquidity assessment process to allow additional technology builds that maybe required by market participants to modify their treatment of a financial instrument. Once the liquidity-classification of an instru-



ment has changed, then we believe this new classification should not apply to existing ‘open’ transactions, but should only be applied to new transactions entered after the re-classification.

<ESMA_QUESTION_114>

Q115: Do you have any proposals on how to form homogenous and relevant classes of financial instruments? Which specifics do you consider relevant for that purpose? Please distinguish between bonds, SFPs and (different types of) derivatives and across qualitative criteria (please refer to Annex 3.6.1).

<ESMA_QUESTION_115>

AFME Response

FIXED INCOME

No. AFME does not agree with a COFIA approach for bonds and SFPs

The only class that we believe is critical is the small issue size subcategory, which is generally illiquid and helps simply the calibration model.

FOREIGN EXCHANGE

For FX, the FX table included within Annex 3.6.1 (Financial instruments taxonomy and metrics for the calculation of the liquidity criteria (average size of transaction) on page 134 of the Discussion Paper references similar taxonomy to that which is included within the ISDA product taxonomy (http://www2.isda.org/attachment/NTQzOQ--/ISDA_OTC_Derivatives_Taxonomies_o_version2012-10-22.xls) and should be used by trading venues and market participants alike to harmonize classification across the FX asset class.

As described previously, the GFXD believes that the FX asset class should be categorized to the sub-product, currency pair level and maturity (e.g. a 3 month EUR/USD Vanilla Option).

With specific reference to Annex 3.6.1 on page 134 of the Discussion Paper, the GFXD would like to state that the reference to ‘cash settled forwards’ be replaced with physically (deliverable) settling FX forward transactions, because cash settled forwards are non-deliverable forward transactions. A non-deliverable forward is an FX financial instrument that involves two transacting parties executing an FX forward contract on the basis of non-delivery (i.e. cash, not physical, settlement) which involves the fixing (i.e. valuation) of the contract and therefore settlement in single reference currency. We also suggest that the ‘FX Swap’ product type should be broken down at the sub-product type to ‘Deliverable Swaps’ and ‘Non-Deliverable Swaps’. Finally, we would like to state, with reference to the ESMA EMIR Q&A, TR Question 1, that cross-currency swaps are ‘financial instruments should be classified as interest rates, in line with current market practice’ rather than as FX instruments. Table 6 below shows a representative illustration of how Annex 3.6.1 could look for FX.

Table 6: Suggested Annex 3.6.1 for FX

| Financial Instrument | Product Types | Sub-Product Types | Recommended Liquidity sub-categories |
|------------------------------|---------------|--|--------------------------------------|
| Foreign Exchange Derivatives | Futures | N/A | Currency Pair |
| | Options | Non-Deliverable Option - NDO (only European type options are NDO - not any other FX options settled in non-deliverable currency) | |
| | | Vanilla Option (European and American) | |
| | Forwards | Deliverable Forward | Maturity |
| | | NDF | |
| | FX Swaps | Deliverable FX Swap | Maturity |
| | | Non-Deliverable FX Swap | |
| | Others | Simple exotic (Barrier & Digital) | Maturity |
| | | Complex Exotic | |

<ESMA_QUESTION_115>

Q116: Do you think that, in the context of the liquidity thresholds to be calculated under MiFID II, the classification in Annex 3.6.1 is relevant? Which product types or sub-product types would you be inclined to create or merge? Please provide reasons for your answers

<ESMA_QUESTION_116>

AFME Response

FIXED INCOME

No. AFME does not agree with the COFIA approach for bonds and SFPs.

We note, however, that we believe that there should be three classes of issue size for the purposes of calculating the liquidity thresholds (as described in answer to **Question 112**): greater than or equal to EUR 5bn, EUR 500mm-5bn, less than or equal to EUR 500mm.

FOREIGN EXCHANGE

For FX, the GFXD would not support any additional merging or the creation of new product/sub product types. The FX table included within Annex 3.6.1 (Financial instruments taxonomy and metrics for the calculation of the liquidity criteria (average size of transaction) on page 134 of the Discussion Paper references similar taxonomy to that which is included within the ISDA product taxonomy (http://www2.isda.org/attachment/NTQzOQ--/ISDA_OTC_Derivatives_Taxonomies_o_version2012-10-22.xls) and should be used by trading venues and market participants alike to harmonize classification across the FX asset class.

As described previously, the GFXD believes that the FX asset class should be categorized to the sub-product, currency pair level and maturity (e.g. a 3 month EUR/USD Vanilla Option).

With specific reference to Annex 3.6.1 on page 134 of the Discussion Paper, the GFXD would like to state that the reference to 'cash settled forwards' be replaced with physically (deliverable) settling FX forward transactions, because cash settled forwards are non-deliverable forward transactions. A non-deliverable forward is an FX financial instrument that involves two transacting parties executing an FX forward contract on the basis of non-delivery (i.e. cash, not physical, settlement) which involves the fixing (i.e. valuation) of the contract and therefore settlement in single reference currency. We also suggest that the 'FX Swap' product type should be broken down at the sub-product type to 'Deliverable Swaps' and 'Non-Deliverable Swaps'. Finally, we would like to state, with reference to the ESMA EMIR Q&A, TR Question 1, that cross-currency swaps are 'financial instruments should be classified as interest rates, in line with current market practice' rather than as FX instruments. Table 7 below shows a representative illustration of how Annex 3.6.1 could look for FX.

Table 7: Suggested Annex 3.6.1 for FX

| Financial Instrument | Product Types | Sub-Product Types | Recommended Liquidity sub-categories |
|------------------------------|---------------|--|--------------------------------------|
| Foreign Exchange Derivatives | Futures | N/A | Currency Pair |
| | Options | Non-Deliverable Option - NDO (only European type options are NDO - not any other FX options settled in non-deliverable currency) | |
| | | Vanilla Option (European and American) | Maturity |
| | Forwards | Deliverable Forward | |
| | | NDF | |
| | FX Swaps | Deliverable FX Swap | |
| | | Non-Deliverable FX Swap | |
| | Others | Simple exotic (Barrier & Digital) | |
| Complex Exotic | | | |

<ESMA_QUESTION_116>

Q117: Do you agree with the proposed approach? If not, please provide rationales and alternatives.

<ESMA_QUESTION_117>

AFME Response

FIXED INCOME

No. AFME does not agree with the proposed approach

- (i) *Calculation of sudden drops in liquidity for the purposes of temporary suspension cannot be based on ADT but should be based on a combination of qualitative criteria and other quantitative criteria*

We agree with ESMA that the purpose of temporary suspension is to address unexpected and sudden drops in liquidity. For the temporary suspension provisions to be fit for purpose, the measures need detect sudden drops in liquidity in real time (or thereabouts) and apply immediately. As such, the periodic liquidity assessment approach proposed for the assessment of a liquid market is not appropriate for the temporary suspension. If the calculation requires a period of data collection, it will not be able to detect sudden drops of liquidity in the timeliness needed to protect the markets and mitigate financial stability risks.

We do not agree with using ADT to measure sudden drops in liquidity. This measure would not be sufficiently timely – it would require a period of testing and as ESMA observes, it extremely uneven distributions, it might not correctly capture the decline. Nonetheless, we agree with ESMA that a **combination** of qualitative criteria in combination with quantitative criteria.

Identifying and operationalising an appropriate temporary suspension regime that detects extreme market circumstances quickly will be highly challenging for ESMA. Given the difficult nature of introducing a workable temporary suspension regime, we stress that it is even more important that ESMA sets the liquidity thresholds appropriately (discussed in response to **DP Question 112**).

- (ii) ***ESMA should develop a non-exhaustive list of market events***

We recommend that the simplest way to detect sudden drops in liquidity is to identify significant market events. We recommend for the RTS to list these market events but to remain non-exhaustive such that ESMA can make a determination on additional market events in the future. We would be concerned that an exhaustive list cannot be future-proof and would result in the financial instability if an extreme event occurred that did not happen to be on the list.

We propose the RTS to provide that in the event that the following events occur, there will be temporary suspension of the transparency requirements in the instrument:

| Market event | What the temporary suspension will apply to |
|---|--|
| Default of an issuer | All bonds issued by the issuer |
| Downgrade of the issuer | All bonds issued by the issuer |
| Downgrade of the country of the issuer | All bonds issued by issuers incorporated in the downgraded country |
| Downgrade of the instrument | The bond in question |
| Delisting of an instrument by a venue | The bond in questions |
| A war in the country of the issuer | All bonds issued by issuers incorporated in the affected country |
| A natural disaster in the country of the issuer | All bonds issued by issuers incorporated in the |

| | affected country |
|---|------------------|
| Technological issues including problems with a data feed or other system that is essential in order to be able to carry out a market making strategy; and (aligned with paragraph 41 – section 4.4 – market making strategies) | |
| Internal risk management issues, which would encompass problems in relation to capital or clear- aligned with paragraph 41 (section 4.4 market making strategies) | |

(iii) Quantitative assessment of drops in price should determine temporary suspension

We agree with ESMA that a quantitative means to detect sudden drops in liquidity would be useful. AFME would be happy to work with ESMA to identify a workable regime. AFME has two ideas that could work:

Apply temporary suspension when there is a sudden price drop – this could be workable for government bonds because, in most cases, there is sufficient price data. However, changes in price do not work as a measure for corporate bonds because there is not sufficient intra-day pricing available.

Instead, the price change of a share of the issuing company could be used as a proxy for changes in bond prices - typically, there is sufficient intra-day pricing information for shares. If there is a sudden significant decrease in the share price of a particular company, we believe that it could be fair to make a determination that the prices of the bonds issued by the company will have significantly decreased as well. Therefore, we recommend for such an event, all the bonds issued (for SFPs – where the issuer has originated the underlying loans) by the affected issuer will be subject to the temporary suspension requirements based on the price drop of the share.

Apply temporary suspension when there is a sudden drop in the number of market participants in that instrument on venue – alternatively, a drop in the number of market makers providing two-way pricing on a venue in a particular instrument could indicate that there is a sudden drop in liquidity. However, we note that such an approach would not be workable for any instrument other than government bonds. Even for government bonds, it is unclear how this would work in practice.

(iv) Treatment of information relating to trades that occur during temporary suspension

We recommend that ESMA should not require the information that relates to trades during the period that an instrument is subject to temporary suspension to be published following the lapse of temporary suspension. Trade information during this period is highly sensitive because it relates to extreme circumstance and remains sensitive even following the lapse of the extreme market event. If the information was to be made public, it would discourage the market makers from providing liquidity in extreme market circumstances, which would result in procyclical effects (such as runs) and significantly increase financial stability risks. Therefore, it is the instrument that is subject to the temporary suspension not the trade information.

(v) Operational structure for temporary suspension

As ESMA recognises, a quick and straightforward assessment of liquidity for the purposes of temporary suspension is of utmost importance. We recommend that it is also critical that the

application of the thresholds can be undertaken in a quick and straightforward manner – i.e. if the threshold can be applied immediately but the approval process for applying the threshold takes days or weeks, temporary suspension will not be fit for purpose.

We recommend for temporary suspension to be applied in the following manner: when conditions for temporary suspension arise (as set by ESMA), investment firms and market operators make an application for temporary suspension. As temporary suspension needs to be implemented quickly and urgently, we suggest that the suspension apply to all market participants in that instrument once the application is received and is at least put on the website in a machine readable format of the receiving national authority and ESMA together with a notification (e.g. by email) being sent to market participants. It is critical that there is a level-playing field between market participants, such that the suspension applies to all participants at the same time and all market participants have the knowledge that the suspension is in place. However, as timing will be critical, suspension needs to apply immediately following receipt and acknowledgement of the application of temporary suspension. We recommend an ESMA taskforce review the suspension within a reasonable time and determine whether it should remain in place or reject the application and lift the suspension. Market abuse regulation should address any attempts to exploit the temporary suspension protocol.

Our proposed approach is broadly consistent with the operationalisation of the short selling regulations in relation to short sale bans, though that system is neither as simple as we propose nor optimal.

Under SSR Article 23(4), national authorities have the power to temporarily impose a short sale ban, and must notify ESMA of that decision at the latest within 2 hours after the end of the trading day on which the decision was taken. ESMA then must immediately inform the competent authorities of the member states where the securities trade on a venue in that member state. In practice, in terms of notifying market participants, national authorities publish a press release/update their website with the news (so that it feeds RSS announcements), and ESMA then updates its own website with the same information once it is also informed.

(vi) Expiration or renewal of temporary suspension

Following the three-month period of a temporary suspension, the determination as to whether the suspension is renewed or lifted cannot be based on price. A market event may cause the price of an instrument to drop but after three months, the liquidity of the instrument may return but the price may not resume to pre-event levels (it may adjust to a new level). Therefore, we suggest that ESMA needs to determine whether the suspension for an instrument is renewed or lifted based on whether liquidity has returned to the same level prior to the initial application for temporary suspension. This can be done by comparing the frequency and ADT of the instrument in the third month of suspension to the frequency and ADT of the instrument in the month prior to suspension.

FOREIGN EXCHANGE

For FX, the GFXD partially supports the proposed approach and would like to state that there needs to be a consistent application of any temporary suspension of liquidity across all NCAs in Europe and not in one jurisdiction only. FX transactions are executed across borders and any divergence in approach could lead to a bifurcated market.

As the FX market operates globally 24 hours a day, for 5.5 days of the week, and that currencies are generally more liquid when their sovereign markets are open, ESMA and National Competent Authorities also require the tools to intervene and suspend a specific financial instrument intra-day should the need arise. The FX markets are often impacted by ad-hoc disruption events



(geo-political or environmental in nature) and market participants may require regulatory intervention should such an event occur.

<ESMA_QUESTION_117>

Q118: Do you agree with the proposed thresholds? If not, please provide rationales and alternatives.

<ESMA_QUESTION_118>

AFME Response

FIXED INCOME

No. AFME does not agree.

A decrease in ADT would not be sufficiently timely for measuring sudden drops in liquidity – it would require a material testing period (thereby drops in liquidity would be detected far too late) and as ESMA observes, it extremely uneven distributions, it might not correctly capture the decline. Please see AFME’s answer to **DP Question 117**.

FOREIGN EXCHANGE

For FX, the GFXD requests further information on the proposed thresholds of 80% for liquid instruments and 60% for illiquid instruments. The GFXD suggests that as part of wider threshold assessments, that data is analysed, based on a 2 year cycle, to validate any thresholds. Such data should be collated to reflect the global nature of the FX market, and any thresholds should be set in collaboration with other global regulators and market participants. The GFXD has long supported a globally harmonized regulatory agenda and any regional variance from this could cause unintended consequences such as the fragmentation of liquidity to the detriment of the end-user.

We would also be concerned that for a global market such as FX, any European regional specific suspensions of a financial instrument could cause significant issues for participants within that specific area. For instance, should a product be deemed illiquid in one specific region, market participants in that region could be shut off from accessing liquidity in that specific financial instrument, whilst other participants residing in unaffected European regions could carry on trading as before. Impacted participants would be at increased risk of default, un-hedged positions and increased financing costs.

The GFXD suggests that a mechanism exists to allow market participants to request temporary suspension of a financial instrument in conditions where a suspension threshold has not been met, but that market conditions or unintended regulatory consequences result in the unwarranted changes in the trading patterns of the market, or in increased risks occurred by market participants.

<ESMA_QUESTION_118>

3.7. Pre-trade transparency requirements for non-equity instruments

Q119: Do you agree with the description of request-for-quote system? If not, how would you describe a request-for-quote system? Please give reasons to support your answer.

<ESMA_QUESTION_119>

AFME Response



FIXED INCOME

No. We do not agree with ESMA's definition of request for quote:

As ESMA indicates in paragraph 10 of Section 3.7, the defining feature of these systems is the provisions of liquidity from members to market participants only on request and the requesting participant is the only counterparty to which the quote is disclosed and the only counterparty entitled to trade against it. The latter feature (the exclusivity feature) has not been incorporated into ESMA's definition. We strongly recommend that this feature is an essential part of the request for quote system.

Further, generally in a RFQ system, a market participant typically requests a quote following the provision of an indicative price or indicative prices. These indicative prices are not firm and are an essential part of trading. A quote no longer becomes indicative when the price becomes firm. ESMA states that an actionable indication of interest contains all necessary information to agree a trade – this does not mean the details of the trade such as price and volume. The distinguishing feature between an actionable indication of interest (AIOI) and an indicative price is that the AIOI is firm.

Therefore, we recommend the following definition:

*“A trading system where a quote or quotes are provided to a member or participant in response to a request **for a quote submitted** by one or more other members or participants. **The quote is exclusively provided to the requesting member or market participant and is indicated to be a firm quote.** The requesting member or participant may conclude a transaction by accepting the quote or quotes provided to it on request.”*

We do, however, agree with ESMA that the definition should be sufficiently broad to capture a variety of protocols sharing the same core characteristics.

FOREIGN EXCHANGE

For FX, the GFXD suggests that text should be added to the definition of a request-for-quote system to clarify that the quote provided is for the requesting party only as referenced Section 3.7 'Pre-trade transparency requirements for non-equity instruments' # 10 of the Discussion Paper, page 149:

10. The requesting participant is the only counterparty to which the quote is disclosed, and the only counterparty entitled to trade against it.

Also, for clarity we would like to re-iterate that we understand the term 'system' with respect to this definition to be used only in the context of multi-lateral trading practices, and not those employed for bi-lateral trading.

<ESMA_QUESTION_119>

Q120: Do you agree with the inclusion of request-for-stream systems in the definition of request-for-quote system? Please give reasons to support your answer.

<ESMA_QUESTION_120>

AFME Response



FIXED INCOME

AFME partially agrees

If the investment firm responds to the client with quotes that are indicated to be firm (i.e. actionable), the protocol is RFQ. As discussed in answer to **DP Question 119** in relation to RFQ protocols, if the stream provided is not firm, then it is indicative.

FOREIGN EXCHANGE

For FX, the GFXD believes that trading protocols should not be exclusively grouped into an ESMA trading system. The ESMA trading system notations should be determined for trading protocols on a case- by-case basis based on the core characteristics. The trading venue or investment firm should declare the type of ESMA trading system notation the protocol falls under. There are a broad array of trading protocols that are appropriate for the highly heterogeneous FX market and, as such, it is inappropriate to attempt to categorise specific trading protocols.

With regards to request-for-stream systems, if the stream provided is indicative, the request-for-stream should not fall under the RFQ trading system notation. This is because, the firm is not responding to the client with quotes but indicative prices. If the firm responds to the client with quotes, which are indicated as such (for a predefined period of time), the system would fall under the request for quote system notation.

<ESMA_QUESTION_120>

Q121: Do you think that – apart from request-for-stream systems – other functionalities should be included in the definition of request-for-quote system? If yes, please provide a description of this functionality and give reasons to support your answer.

<ESMA_QUESTION_121>

AFME Response

FIXED INCOME

No. As above, AFME believes that the determination as to whether a trading protocol is request for quote should be based on core principles rather than categorisation of types of protocols.

Trading protocols should not be exclusively grouped into an ESMA trading system. The ESMA trading system notations should be determined for trading protocols on a case- by-case basis based on the core characteristics. The trading venue or investment firm should declare the type of ESMA trading system notation the protocol falls under. Fixed income has a broad array of trading protocols that are appropriate for the highly heterogeneous fixed income market and, as such, it is inappropriate to attempt to categorise specific trading protocols.

FOREIGN EXCHANGE

For FX, the GFXD does not believe that other functionalities should be included in the definition of a request-for-quote system.<ESMA_QUESTION_121>

Q122: Do you agree with the description of voice trading system? If not, how would you describe a voice trading system?

<ESMA_QUESTION_122>

AFME Response

FIXED INCOME

No. AFME does not agree with the definition

The current definition proposed by ESMA is: “A *trading system where transactions between members are arranged through voice negotiation*”

AFME recommends the following definition:

“A trading system where transactions between members are arranged *actively by the operator of trading venue through voice negotiation or any medium that replicates voice negotiation*”

(i) *The operator of the trading venue must be actively arranging transactions between members/market participants*

This definition suggests that the venue can be passive in the voice negotiation. If this is the case, a telephone company or another type of telecommunications company (e.g. providing instant messaging) providing the dealers and clients with the communication systems to bilaterally trade would be classified as a voice trading venue and would need to register as an RM, MTF and OTF. This cannot be correct. The trading venue providing the voice trading system needs to take an active role in the arrangement of the trade.

(ii) *Voice trading systems should include any medium that replicates voice negotiation*

AFME does not agree with this narrow definition of the term "voice trading system" since it does not describe the current accepted market model. There is no definition of the term 'voice negotiation' and further limiting of the definition only to negotiation through voice may exclude the completion of transactions. Indeed, voice trading system as prescribed does not appear to include the one to one negotiation that may be carried out by other means such as compliant and recorded instant messaging systems or email (which may then be stored in a 'durable medium' as defined under MiFID record keeping requirements).

This wider, integrated and essentially 'hybrid' scope describes the current operation of the wholesale multilateral market in which technologies that replicate and enhance voice execution, and which are able to store details on a durable medium, are widely employed.

In the view of AFME, a voice trading system should include hybrid execution methodologies for which there are multiple means of communications. Further, we would note that in the US under Dodd-Frank, 'voice' covers forms of electronic communication other than those involving the spoken word, such as, instant messaging and email under the term 'by any means of interstate commerce'. Therefore the AFME would specifically request that the definition be expanded to "*... or any medium that replicates voice negotiation*".

FOREIGN EXCHANGE

For FX, the GFXD does not agree with the current description of a voice trading system. The current definition proposed by ESMA is: “A trading system where transactions between members are arranged through voice negotiation”.

This definition suggests that the venue can be passive in the voice negotiation. If this is the case, a telephone company or another type of telecommunications company (e.g. providing instant messaging) providing the dealers and clients with the communication systems to bilaterally trade would be classified as a voice trading venue and would need to register as an RM, MTF and OTF. This cannot be correct. The trading venue providing the voice trading system needs to take an active role in the arrangement of the trade.

Further, the term voice trading should be consistent with the current evolution of market technologies that mimic voice execution. In our view, voice trading should include hybrid execution methodologies for which there are multiple means of communication. Further, we note that in the US under Dodd-Frank, voice covers forms of electronic communication other than those involving spoken word, such as, instant messaging and email under the term “any means of interstate commerce”. We recommend ESMA to also adopt such an approach.

Therefore, we recommend the following definition:

“A trading system where transactions between members are arranged actively by the operator of trading venue through voice negotiation”

<ESMA_QUESTION_122>

Q123: Do you agree with the proposed table setting out different types of trading systems for non-equity instruments?

<ESMA_QUESTION_123>

AFME Response

FIXED INCOME

No. AFME does not agree.

We stress the importance of ensuring that the trading system protocols are workable for fixed income and are not solely based on the equities systems.

Taking the **description** of each type of trading system in turn:

- **Continuous auction order book trading system** – we agree with the description
- **Quote-driven trading system** – we consider that a quote-driven trading system captures protocols whereby continuous firm quotes are streamed out or are provided to participants/members of venues without a request in the first instance. For a quote to be considered firm, it needs to be indicated as firm. If the price is indicative (i.e. a member may indicate interest in the price but the provider of the indicative quote can make a determination to respond to the request for a price (which may or may not be the same as the indicative price – i.e. the firm may keep the price the same and make it firm or provide a new price on a firm basis), then it should not fall within the quote driven trading system

Further, we recommend that the definition is amended to the following: “A system where the transactions are concluded on the basis of firm quotes that are continuously made available to participants”. Specifically, we recommend that the requirement in the definition for market makers to maintain quotes to be deleted – otherwise the definition does not align with nature of the fixed income markets, which is generally less liquid than the equities market, whereby a quote driven system could be used to provide sporadic prices rather than maintaining prices on an ongoing basis.

“A system where transactions are concluded on a basis of firm quotes that are continuously made available to participants”

- **Periodic auction trading system** – we agree with the description
- **Request for quote** – we suggest the description needs to be updated as suggested below to take into account the key aspects of features for quote discussed in **DP Question 119**

“A trading system where a quote or quotes are provided to a member or participant in response to a request **for a quote submitted** by one or more other members or partici-

pants. The quote is exclusively provided to the requesting member or market participant and is indicated to be a firm quote. The requesting member or participant may conclude a transaction by accepting the quote or quotes provided to it on request.”

- **Voice trading system** – we suggest the description needs to be updated to reflect the changed proposed in **DP Question 122**:

*“A trading system where transactions between members are arranged **actively by the operator of trading venue through voice negotiation or any medium that replicates voice negotiation**”*

- **Trading system not covered by the first five rows** – we have no comments on this

We note that in paragraph 19, ESMA states that an actionable indication of interest should be treated in the same way as a bid or offer or firm quote, where it contains all the necessary information to trade. We do not believe that this is correct – an indicative price could be interpreted as having “the necessary information to trade”. An actionable indication interest should only be treated in the aforementioned manner if it is indicated as firm – only then does a market participant have all the information it needs to trade.

FOREIGN EXCHANGE

For FX, the GFXD recommends that the voice trading system text is updated to include reference to the multi-lateral nature of a voice trading system (as per our response to question 122) and that the request for quote text is updated to include reference that the quote is provided for the requesting party only (as per our response to question 119).

Also, for clarity we would like to re-iterate that we understand the term ‘system’ to be used only in the context of multi-lateral trading practices, and not those employed for bi-lateral trading.

Otherwise, the GFXD agrees with the content of the proposed table.

<ESMA_QUESTION_123>

Q124: Do you think that the information to be made public for each type of trading system provides adequate transparency for each trading system?

<ESMA_QUESTION_124>

AFME Response

FIXED INCOME

Disclosure on a price-by-price basis for RFQ could have unintended consequences

AFME understands ESMA’s objective to increase pre trade transparency in line with the MiFID II mandate. However, we are concerned that there will be significant adverse impacts as a result of excessive transparency on RFQ systems. These unintended consequences are explained below.

We believe that, for RFQ systems, making the “bids and offers and attaching volumes submitted by each responding entity” pre trade transparent may have serious counter-productive effects. The requirements are disproportionately onerous and do not provide the relevant transparency. As at today, the answers provided to a request-for-quote are only known to the entity which submitted the request. The entities answering to the RFQ do not see the prices provided by the

other responding entities and, more importantly, third parties. This asymmetry of information is justified by the fact that the responding entities take on risk that would be increased, with no benefit for both parties, if the bids and offers were made publicly known. As the fixed income market is generally quite illiquid, disclosure on a price-by-price basis to the wider public pre trade disclosure could have severe consequences. Specifically, it is essential that market makers on venue operating an RFQ protocol are not required to disclose pre trade prices to other market makers (i.e. other price makers).

Requests for quotes on and off venues are privately negotiated. The responses that are returned to the client (from the dealers the client requests quotes from) are bilaterally private, in other words, the dealers that are party to the request for quote will not see each other's quotes. This allows market makers to protect their risk by ensuring that no-one can move the market against the potentially winning quote. Once the client has secured the best price within the live auction and the dealer subsequently accepts the trade, that winning dealer is privy to immediate cover information (i.e. the differential between the accepted price and the next best price). The other dealers will know, after a rules-determined time period, if they covered, tied or if they traded away (typically meaning they provided the 3rd or least best price). Again, the post trade information that is disseminated is deliberately designed to ensure that winner's curse is reduced as much as possible and is only available to those dealers that participated in the RFQ process.

If full disclosure was required to the wider public, the risk for the responding entity would increase as other price makers could price against them, leading a cumulative impact of dealers pricing against each other (i.e. a race to the bottom), resulting in increased financial stability risks and market makers that are unable to hedge their risks/unwind their positions. .

This is all the more important as, outlined in paragraph 10, RFQ systems are prevalent only for those markets/instruments characterised with insufficient trading interest to support continuous trading. Such instruments are often characterised by:

- The fact that, for a given instrument/class of instruments, investors often have similar interests at the same time, so that revealing an interest is equivalent to revealing the side of the position taken by the counterparty to this interest;
- The difficulty for liquidity providers to find a counterpart to unwind their position, leading them to manage imperfect hedges.

For these instruments, imposing full transparency on bids and offers provided by entities responding to RFQs would increase the risk taken by market makers in a domain where no effective hedge is available. As a result, it would discourage market makers to answer RFQs and would increase investor costs, leading to greater borrowing costs for issuers.

We understand that ESMA is limited by the Level 1 requirements, which requires venues to disclose bids, offers and depth of trading interest to the public (Article 8 MiFIR). However, we note that MiFIR Article 8 provides that the pre trade transparency requirements should be calibrated to the trading system.

(i) Venues should disclose the average prices at instrument level for RFQ systems

The optimal solution would be to limit venue pre trade transparency disclosure for RFQ systems to price takers only (i.e. quotes are not disclosed to other market makers); however, we understand the challenges ESMA would face if it were to look to implement such a regime, namely the interpretation of the Level 1 mandate.

Therefore, we propose that the above risks could be mitigated by requiring venues to provide average prices at instrument level for RFQ systems.

Notably, the disclosure requirements for continuous auction order book trading systems, which highly liquid markets use, are less onerous than the proposed requirements for RFQ and voice trading, which as ESMA has recognised attracts markets which have insufficient frequency trading interests to attract continuous quoting. Specifically, order book trading systems need to disclose the five best bid and offers and RFQ systems need to disclose the bid and offers and attaching volumes submitted by each responding entity. A more onerous disclosure regime on RFQ systems is not appropriate.

(ii) *Volume information should not be disclosed for RFQ and voice trading systems*

For voice systems, we do not believe that volume is necessary for pre trade transparency to the public. For participants on the venue, the volume is important information; however, for members of the public the instrument and the bid/offer should be sufficient. We note that for the majority of fixed income markets, the users of this information would rarely be retail.

Further, the requirement for pre trade transparency as recommended by ESMA is unsuitable for voice trading systems. The information required to be made public is impractical to collect. It would require the broker to input voice bids and offers electronically whenever they are received by the broker.

FOREIGN EXCHANGE

For FX, the GFXD believes that the ESMA's proposed transparency requirements for RFQ trading could lead to issues that adversely impact market liquidity. It is of critical importance to the wellbeing of the market that the positions of liquidity providers are not publically exposed, nor that their positions be calculated or implied. The exposure of a liquidity providers position to the market will have the following impacts: i) the provider may be unable to effectively hedge their position; ii) the costs of executing will be increased and these costs will be reflected in wider spreads to the client; iii) the provider may decide to stop offering quotes in certain instrument should they be unable to effectively manage their subsequent position.

The GFXD suggests that a suitable mechanism should be implemented to either defer the information being publically reported or to sufficiently mask the information so that global market participants are not able to calculate the positional impacts of the transaction, and we are happy to further discuss this with ESMA.

<ESMA_QUESTION_124>

Q125: Besides the trading systems mentioned above, are there additional trading models that need to be considered for pre-trade transparency requirements in the non-equity market space?

<ESMA_QUESTION_125>

AFME Response

FIXED INCOME

No. AFME does not believe there are any further systems that need to be added

FOREIGN EXCHANGE

For FX, the GFXD believes that the proposed table covers the multi-lateral trading venues available in the non-equity markets.



<ESMA_QUESTION_125>

Q126: If you think that additional trading systems should be considered, what information do you think should be made public for each additional type of trading model?

<ESMA_QUESTION_126>

AFME Response

FOREIGN EXCHANGE

For FX, the GFXD believes that the proposed table covers the multilateral trading venues available in the non-equity markets.

<ESMA_QUESTION_126>

Q127: Based on your experience, what are the different types of voice trading systems in the market currently? What specific characteristics do these systems have?

<ESMA_QUESTION_127>

AFME Response

FIXED INCOME

- Voice on voice trading– whereby one or more brokers speak to one or more clients or counterparties either through spoken or through email or instant messaging.
- Voice on electronic trading– whereby the trader asks the broker to act on his/her behalf through voice, the broker can then act on his/her behalf via non- voice electronic means.

In addition, ESMA should also note that technology does allow a voice system to carry out one-to-many as well as one-to-one.

FOREIGN EXCHANGE

For FX, the GFXD believes that the following are the key voice trading systems available in the non-equity markets:

- ‘Voice on voice’ trading: whereby one or more brokers speak to one or more clients or counterparties either through spoken or through email or instant messaging.
- ‘Voice on electronic’ trading: whereby the trader asks the broker to act on his/her behalf through voice means following which the broker acts on his/her behalf via non- voice electronic means.

<ESMA_QUESTION_127>

Q128: How do these voice trading systems currently make information public or known to interested parties at the pre-trade stage?

<ESMA_QUESTION_128>

AFME Response



FIXED INCOME

IDBs widely advertise pre-trade information to all interested parties in the trading system through many different mechanisms, including:

- Indicative screen prices or other price related factors (such as yields, rates, volatilities or correlations)
- Announcements via telephone or voice box or through electronic messaging and/or email
- Reports of RFQ / RFS requests

As previously mentioned, most voice trading systems are in products with a strict professional and eligible participants market only ("wholesale") and have no participation by 'retail clients'. On this basis there is very little pre-trade information currently given to the public due to the absence of demand.

For participants, it is in the arranger's best interest to disseminate and advertise order information to all participants as soon as possible in order to increase the chances of a concluding trade. Therefore, by default, members get the necessary pre-trade information.

FOREIGN EXCHANGE

For FX, the GFXD considers that in addition to other factors, trades executed via voice trading systems are normally incorporated into the market makers pricing engines to determine their bid-offer prices. These prices are then displayed as part of the wider FX prices publically available, such as those streamed to other public venues, such as Bloomberg.

<ESMA_QUESTION_128>

Q129: Do you agree with ESMA's approach in relation to the content, method and timing of pre-trade information being made available to the wider public?

<ESMA_QUESTION_129>

AFME Response

FIXED INCOME

No. AFME does not agree with ESMA's approach

(i) Venues should disclose average prices for RFQ systems

As discussed in Question 124, we recommend that venues should provide average prices at instrument level on a continuous basis for RFQ systems.

We believe a regime whereby price-by-price level information is disclosed to the wider public is unworkable. We do not agree with the ESMA proposals on making pre-trade information available to the wider public. The public in our eyes being retail clients as defined under MiFID 1. It would place a great burden on firms and venue operators to comply with this requirement and for no discernible benefit given the wider public would not have an active interest in these specialised professional dominated markets.

(ii) Voice trading systems should not be mandated to comply with their requirements in a prescribed manner

We do not believe it appropriate for ESMA to dictate an exhaustive list of methods a trading system should use to fulfil its disclosure requirements (i.e. paragraph 21). We recommend that if a venue fulfils its requirements in an alternative manner, then it should be permitted to do so.

FOREIGN EXCHANGE

For FX, the GFXD believes that the ESMA's proposed transparency requirements for RFQ trading could lead to issues that adversely impact market liquidity. It is of critical importance to the wellbeing of the market that the positions of liquidity providers are not publically exposed, nor that their positions be calculated or implied. The exposure of a liquidity providers position to the market will have the following impacts: i) the provider may be unable to effectively hedge their position; ii) the costs of executing will be increased and these costs will be reflected in wider spreads to the client; iii) the provider may decide to stop offering quotes in certain instrument should they be unable to effectively manage their subsequent position.

The GFXD suggests that a suitable mechanism should be implemented to either defer the information being publically reported or to sufficiently mask the information so that global market participants are not able to calculate the positional impacts of the transaction, and we are happy to further discuss this with ESMA.

The global FX market is already typified as being highly transparent with a large percentage of the market executed electronically and as we state above it is critical that additional transparency requirements do not cause market disruption. Existing electronic trading channels provide market participants the ability to compare prices across various dealers as well as providing access to analytical tools, such as historic price charts and opening positions.

Table 8 illustrates the Electronic Trading splits per FX instrument type, split between multi dealer platforms and single dealer platforms. Less sophisticated market participants are also able to obtain data from non dealer platforms, such as Google Finance and Yahoo Finance, as well as from providers such as Bloomberg and Reuters. As can be seen, over 70% of the FX forward market and over 40% of the FX swap market is executed electronically, with the more complex instruments such as FX options being manually traded, primarily due to the high level of customization required by the end-user. Table 9 illustrates the significant impact such electronic trading practices have had on the global FX market, mirroring the data published in Table 8. Table 10 illustrates the numerous channels available to the market in accessing FX trade information.

Table 8: Electronic Trading uptake by FX Instrument

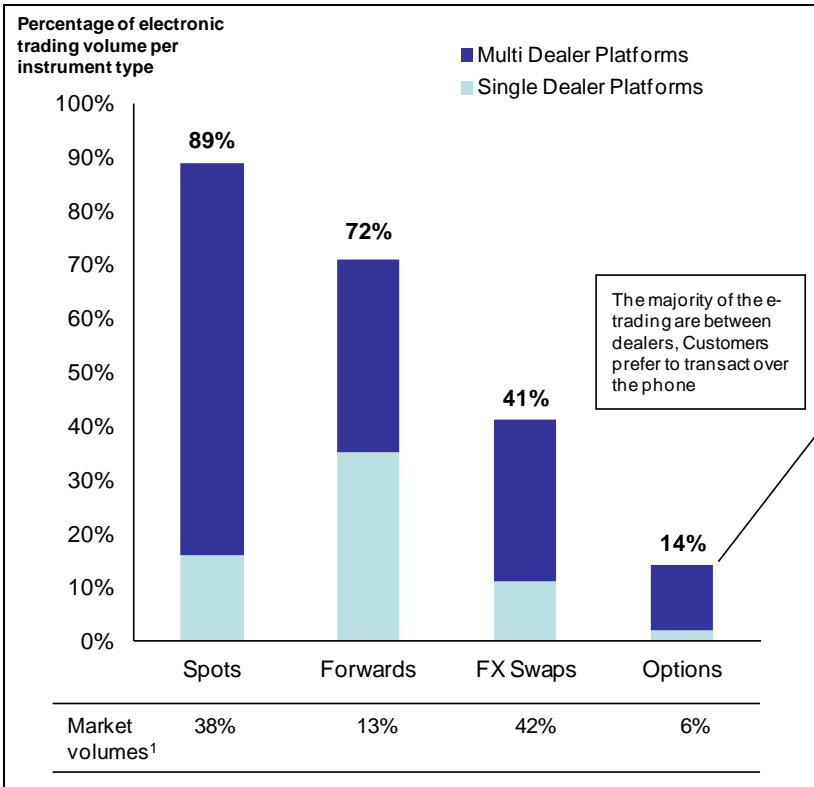

Percentage of trading volume in 2013

Source: BIS, Greenwich Associates, Oliver Wyman analysis, GFXD estimates. Note BIS estimates of spot e-trading range from 64% to 95%. See BIS Quarterly Review, Dec 2013, page 34 footnote 10

Table 9: Impact of Electronic Execution on Transparency for FX instruments (Oliver Wyman)

| FX Instrument type | Overall market share | Electronic order entry | Visible market price | Visible market depth | Order flexibility | Algo access |
|---------------------------------|----------------------|------------------------|----------------------|----------------------|--------------------|--------------------|
| Spot | ▪ 38% | Highly transparent | Highly transparent | Highly transparent | Highly transparent | Highly transparent |
| Forwards | ▪ 13% | Highly transparent | Highly transparent | Highly transparent | Highly transparent | Highly transparent |
| FX Swaps | ▪ 42% | Highly transparent | Highly transparent | Highly transparent | Highly transparent | Highly transparent |
| Options | ▪ 6% | Highly transparent | Highly transparent | Highly transparent | Highly transparent | Least transparent |
| Exchange Traded (member) | ▪ ~2% | Highly transparent | Highly transparent | Highly transparent | Highly transparent | Highly transparent |
| Exchange Traded (retail access) | ▪ ~2% | Highly transparent | Highly transparent | Highly transparent | Highly transparent | Highly transparent |

Increase level of complexity and customisation

● Highly transparent ○ Least transparent

Dodd Frank and MiFID will see both FX options and NDFs move to new execution regimes – SEFS and MTFs – increasing transparency in these products

Table 10: Publicly available sources for FX trade data (Oliver Wyman)

| Source | Examples | Products | Bid / ask | Charting | Trading access |
|---------------------------|--|---|-----------|----------|----------------|
| Web portal | <ul style="list-style-type: none"> ▪ Yahoo Finance ▪ Google Finance | <ul style="list-style-type: none"> ▪ Spots | ✗ | ✓ | ✗ |
| Data Vendor | <ul style="list-style-type: none"> ▪ Bloomberg ▪ Reuters ▪ NetDania (free for personal use) | <ul style="list-style-type: none"> ▪ Spots ▪ Forwards / FX swaps ▪ Vanilla options | ✓ | ✓ | ✓ / ✗ |
| Retail aggregators | <ul style="list-style-type: none"> ▪ OANDA ▪ FXCM (can open dummy accounts for price info) | <ul style="list-style-type: none"> ▪ Spots | ✓ | ✓ | ✓ |
| SDP | <ul style="list-style-type: none"> ▪ Bank platforms | <ul style="list-style-type: none"> ▪ Spots ▪ Forwards / FX swaps ▪ Vanilla options | ✓ | ✓ | ✓ |
| MDP | <ul style="list-style-type: none"> ▪ FXAll ▪ Hotspot | <ul style="list-style-type: none"> ▪ Spots ▪ Forwards / FX swaps ▪ Vanilla options | ✓ | ✓ | ✓ |
| ECN | <ul style="list-style-type: none"> ▪ EBS ▪ Reuters | <ul style="list-style-type: none"> ▪ Spots ▪ Forwards / FX swaps ▪ Vanilla options | ✓ | ✓ | ✓ |

Pricing in FX market is as transparent as other asset classes, with the additional advantage of real time streaming with no delays due to instrument copyrighting, in comparison with exchanges

The GFXD additionally believes that data which is made publically available by a trading venue should remain the property of the participants to the trade and does not automatically become the property of the trading venue, or even the public who consume the data. Apart from the participants to the trade, other organizations should not be able to gain commercial benefits from this data, for example collating and selling the transactional data to interested 3rd parties.

<ESMA_QUESTION_129>

Q130: Do you agree with the above mentioned approach with regard to indicative pre-trade bid and offer prices which are close to the price of the trading interests? Please give reasons to support your answer

<ESMA_QUESTION_130>

AFME Response

FIXED INCOME

No. AFME partially agrees

We highlight that by making the methodologies public, one should not be able to derive the underlying data. Therefore, we recommend that this should be a requirement for the methodologies.



AFME broadly agrees and this conforms to current market practice where venues publicise their prices and give indications on 'market runs'.

However, AFME notes that any methodology to arrive at indicative bid/offer prices shall be sufficiently flexible to allow for trading via different modalities and conventions across different financial instruments and ESMA should not mandate the venue to broadcast derived and indicative prices where it is unable to reliably make such an indication. We note that in describing how indications are currently made, methodologies are both quantitative and qualitative and have been developed and refined by member firms to serve the needs across the client base.

FOREIGN EXCHANGE

The GFXD agrees with the proposed approach and believes that there needs to be a consistent, uniform approach across all trading venues, irrespective of the specific piece of regulation being implemented. As we have previously discussed, the FX market is global in nature and the market is able to transact across venues in multiple regions. We strongly suggest that any transparency obligations are globally consistent to prevent any unintended consequences with respect to data being made publically available.

Trading venues by their very nature are commercial enterprises and whilst each will have its own strategy and business model, this should not influence how the market complies with regulation.

<ESMA_QUESTION_130>

Q131: If you do not agree with the approach described above please provide an alternative

<ESMA_QUESTION_131>

AFME Response

AFME agrees with the approach

<ESMA_QUESTION_131>

3.8. Post-trade transparency requirements for non-equity instruments

Q132: Do you agree with the proposed content of post-trade public information? If not, please provide arguments and suggestions for an alternative.

<ESMA_QUESTION_132>

AFME Response



FIXED INCOME

No. AFME does not agree.

We agree with ESMA that the content and format of the information made public should be harmonised and standardised as much as possible. In order for the information to be useful for the market, the information reported needs to be consistent and possible to aggregate in a meaningful way. The industry would welcome the opportunity to work with ESMA to develop the details further. AFME provides its recommendations on the details of the information to be published as well as the format. We believe that for the MiFID II publication regime to be workable, the format should be clarified and standardised.

(i) ESMA should prescribe non-public fields for when a firm does not apply data quality protocols and for the purpose of collecting the necessary data to populate the data templates under Article 22

We have noted that ESMA has listed the details of information that is to be made public. However, ESMA has not identified data fields that are necessary for the processing of post trade publication but that are not public – these fields apply if the investment firm opts to have the APA apply the waterfall protocol to ensure consistency of publication and non-duplicative trade prints and to ensure that APAs can provide the necessary information to its NCA for the purposes of Article 22 (i.e. calibration).

We strongly suggest for there to be trade publication protocols in place to ensure that post trade information is not of poor quality. Therefore, we have proposed an expanded list of fields (public and non-public fields) when a firm chooses to have the APA apply the data protocols (as set out in our response to **DP Question 361**. We discuss the non-public fields below together with a publication waterfall. We stress that our response to this question needs to be considered in conjunction with our response to **DP Questions 135, 361** (relating to the functionalities of APAs) and **178** (relating to the data templates for the purposes of calibration).

Further, we would welcome confirmation from ESMA that the trade publication obligations on investment firms set out in Articles 20 and 21 MiFIR are not intended to apply if the relevant transaction is executed on a trading venue (which transaction would therefore be reported by the relevant trading venue in accordance with Articles 6 and 10 MiFIR).

We note that the current trade publication requirements under Article 28 MiFID are clearer in this respect than the obligations under MiFIR, although (i) the closing words of Article 20(2) and 21(4) MiFIR provide support for an interpretation that limits Articles 20 and 21 to transactions executed outside a trading venue, and (ii) Articles 20 and 21 contain provisions aimed at preventing duplication of reporting [Article 20(3)(c) and Article 21(2) and (5)(c)], which provisions would be undermined if a transaction executed on a trading venue had to be reported separately by the investment firm party to the transaction and the trading venue.

We assume that any changes in drafting to the trade reporting obligation between MiFID and MiFIR were not intended to result in duplicate reporting of trades executed on a trading venue, which would be confusing to the market and national regulators alike. We would suggest that ESMA embed such a clarification in the recitals to the Regulatory Technical Standards it drafts.

(ii) Comments on the ESMA proposed public fields and AFME proposed additional fields

Comments on the details of public information

| Data field | AFME comment on the data field |
|------------|--------------------------------|
|------------|--------------------------------|

| | |
|--|--|
| Trading day | AFME agrees with this field. |
| Trading time | AFME agrees with this field. |
| The identifier of the financial instrument | <p>We agree with this field; however there should be an additional field – “<i>identifier type</i>”. Depending on the type of instrument, the identifier used will differ.</p> <p>We recommend that the grey market should not be included within the post trade transparency regime. Grey market activity takes place prior to admission to trading on trading venues. If grey market is included, the instruments will most often not have an ISIN code, meaning it is highly likely that the instrument may get published under a number of different reference identifiers. We believe that this would undermine the value of the information.</p> |
| The price at which the transaction was concluded | AFME agrees with this field |
| Price notation | AFME agrees with this field |
| Quantity | AFME agrees with this field |
| Quantity notation | For bonds and SFPs nominal value is a more comparable measure of quantity that can be more consistently populated. |
| Venue identification | <p>AFME agrees with the identification of venues. However, we do not agree with the disclosure of Systematic Internaliser identity (please see reasoning below – DP Question 133).</p> <p>The trading venue identifier is also important for the purpose of processing post trade data. Specifically, where an investment firm has the APA undertake the relevant data quality protocols, the field determines whether the trade has already been published through a European venue. If it has, the APA should suppress the trade publication, otherwise the same trade will be published two or three times, creating distortions in the market. Please see our proposed waterfall below.</p> |

| | |
|-------------------------|--|
| | <p>The MIC code is the identifier code of the venue. Notably, only European venues are subject to the post trade publication rules; therefore, it is essential for ESMA to maintain and publish a list of all European registered trading venues together with their MIC codes to ensure that APAs and firms can identify whether the trade will already be published.</p> |
| Currency | <p>NEW: ESMA has not included a currency field – this is absolutely critical for publishing the quantity and should be in the settlement currency of the nominal</p> <p>It should be noted that a small number of instruments trade in multiple currencies. It is important to ensure that this field is populated consistently. We propose for the settlement currency to be used.</p> |
| Publication time | <p>NEW: <i>it is important for the publication time to be published – this is important for firms to ensure that they are compliant with the requirements given the APAs will be publishing the trades.</i></p> |

(iii) Proposed standards and formats for public fields

| Data field | Proposed format of published output | Comments |
|-------------------|--|--|
| Trading day | <p>yyyymmdd</p> <p>Standard way to represent this to follow ISO 8601 /EN 28601</p> | <p>The trading day should relate to the day the trade was executed.</p> |
| Trading time | <p>In line with the TRACE system, the time should be entered in military time format. HHmmss (except that seconds may be entered as “00” if the investment firm’s or venue’s system is not capable of reporting seconds).</p> <p>For example, if the trade was executed at 2:30pm, the</p> | <p>This should be the execution time. The execution time should be when the price and volume of the trade has been agreed.</p> <p>It is essential that one time zone is used – this should be UTC This has also been adopted for EMIR, which would ensure operational consis-</p> |

| | | |
|--|--|---|
| | execution time should be reported as 1430000 ¹³ . | tency. Also, it is not sensitive to daylight savings. |
| Instrument identifier type | <p>ISIN (for bonds and SFPs)</p> <p>For other instrument types – the appropriate identifier should be identified.</p> | <p>It is essential that firms do not use different identifiers to publish or report trades on the same instrument.</p> <p>For bonds, the identifier type should be the ISIN. When a bond has been admitted to trading on a trading venue, an ISIN will have been issued. For post trade publication, the requirements are for instruments traded on a trading venue; therefore, the instrument should have an ISIN.</p> |
| Instrument identifier | Enter the appropriate ISIN code (for bonds and SFPs) | |
| The price at which the transaction was concluded | <p>The price at which the trade was executed as a percentage of par for bonds and SFPs</p> <p>Valid entry format is 9999.999999</p> | The price must be the clean price (e.g. for agent trades, excluding any commission charged, accrued interest etc....) |
| Price notation | [in line with transaction reporting] | |
| Quantity | <p>In line with TRACE:</p> <p>Volume up to 99,999,999,999.99</p> <p>Commas should not be used the decimal is entered the value after the decimal will be interpreted as .00.</p> | <p>This is the nominal amount</p> <p>It quantity should be the block-level notional value of the trade (as discussed above in DP Question 103], the amount should not be the allocation level trade).</p> |
| Quantity notation | This should be nominal value | |
| Currency | This should be the settle- | |

¹³ FINRA, “TRACE, Reporting and Quotation Service, OTC Corporate Bonds and Agency Debt, User Guide, Version 4.2”, April 25 2014, page 22

| | | |
|----------------------|---|--|
| | ment currency | |
| Venue identification | Venue MIC code Or If the transaction was executed via a Systematic Internaliser, the code “SI” OR “OTC” | |
| Publication time | Same format as trading time above | |

Whilst it is essential that ISINs are used to achieve standardization, we highlight that a significant portion of ISINs are not freely available. Specifically, there are costs and licensing constraints associated with ISINs listed in the US and Canada, which are structured to contain an embedded CUSIP within the ISIN structure that causes CUSIP issuers to demand licenses from companies that redistribute the ISINs within their reporting templates.

(iv) AFME agrees that credit ratings should not be published

We agree with ESMA (paragraph 10) that the credit rating should not be included in the public information as part of post trade transparency. We suggest that it could form part of the reference data of instruments in scope for post trade publication, which we recommend would form part of the lists maintained and made available by ESMA. It cannot form part of the individual firm publication requirements because there are multiple credit rating agencies and firms would select different CRAs and use different methodologies to demonstrate the “overall” credit rating (e.g. the lowest of three, the middle of three etc.). However, if it was to be included within the reference data, ESMA would need to establish a set of rules as to how credit ratings should be evaluated (e.g. how many CRA ratings should be obtained etc.).

(v) Non-price forming trades should not be published

We believe ESMA should not mandate for non-price forming trades to be published. We recommend that these trades fall within the scope of Article 21(5)(b), whereby ESMA has been asked to consider the application of the post trade transparency requirements for transactions determined by factors other than the current market valuation of the instrument. ESMA has proposed to exclude SFT transactions from the requirements. We propose that a consistent approach is adopted for other non-price forming trades.

We should be grateful for clarification from ESMA that intragroup transactions undertaken for the purposes of transferring risk within corporate groups do not need to be trade reported – i.e. an investment firm transferring risk in this way to another group entity should not be considered to have concluded a transaction for the purposes of Article 20 and 21 MiFIR. This would be equivalent to the requirements of the CFTC’s Part 43 reporting rules. Such transactions facilitate the appropriate risk management within a financial group, and do not have any relevance to the price formation process.

We provide the following by way of an example: Group entity A (an investment firm) purchases some bonds from its client. Such bonds are then immediately sold, on a back-to-back (i.e. same price, same quantity) basis, to Group entity B because Group entity B is where the group’s risk in respect of the relevant product is housed. We consider that the trade between Group entity A and its client is the only trade which should be reported in this instance, on the basis that it is this trade which is important to the price formation process, rather than the second trade which is purely undertaken for the purposes of intragroup organisational purposes. Similarly, where Group entity A purchases such bonds through a trading venue, rather than directly from a client, and then enters into a back-to back risk transfer transaction in respect of such bonds with Group entity B, only one trade should be reported to the market. That trade should, per our discussion above, be reported by the relevant trading venue.

AFME also believes that reporting primary trades could prove misleading where you would end up with lots (often hundreds) of late booked trades (after pricing and syndicate allocations had been determined) either with spurious trade times (reflecting booking time which often runs into the night) or simply very late bookings (certainly not anywhere near 5 minutes of execution). In addition, these trades are not price determining, at this stage everyone is a price taker. The consolidated tape would show a significant distortion in the market and exaggerate liquidity from a calibration perspective (the bond could in practice be totally illiquid post trade date if locked up by the buy-side).

Other non-price forming trades include securities financing transactions and trade amendment.

(vi) Non-public post trade data fields for processing

As mentioned above, in addition to the public fields, non-public fields also need to be populated and sent to APAs to ensure that the public data is published in the correct manner. As discussed in our response to Section 5.1 (DP Question 361), we believe that APAs are best placed to apply publication waterfalls. The reason for this is that there will be fewer APAs than investment firm and therefore, it is more likely that there will more standardised and consistent application.

We recommend the following **non-public** post trade fields populated by a self-reporting investment firm and sent to an APA when the investment firm opts to use its APA to apply the waterfall (rather than applying the waterfall in-house using the same information):

| Field | Explanation and purpose |
|--|--|
| Is the counterparty to the trade self-reporting (Yes/No) | <p>This field is for the purpose of the waterfall to avoid duplicative publication. If the firm opts to apply the waterfall itself, it should not be required to send this information to the APA.</p> <p>There will be a contractual arrangement between dealers and each of their counterparties as to whether their counterparties will delegate reporting and thereby take up a non-self-reporting status. It should be noted these are bilateral arrangements and a counterparty may choose to be self-reporting with one dealer and non-self-reporting with another.</p> |

| | |
|-------------------|---|
| | <p>It is important for firms to populate this field to identify whether two self-reporting parties will publish the trade through an APA (which may very well be different APAs). In order for a waterfall to be applied to ensure that there is no duplicative reporting, this field is essential.</p> <p>The waterfall will be such that if the counterparty is non-self-reporting, then the trade will be published by the APA. If this field is not introduced as a non-public field, it may result in firms inconsistently applying the waterfall as there is no mandated field to ensure counterparty self-reporting field is appropriately documented and populated.</p> |
| Buyer/Seller | <p>This field is for the purpose of the waterfall to avoid duplicative publication. If the firm opts to apply the waterfall itself, it should not be required to send this information to the APA.</p> <p>This field is important for, again, the application of the waterfall to ensure that there is no duplicative reporting. In the event that there are two self-reporting counterparties sending the trade to APAs, the APA receiving the buyer's information will suppress the trade and the APA receiving the seller's trade will publish the information</p> |
| On behalf of LEI | <p>This is to enable the investment firm to differentiate between its own trades and those of its clients.</p> <p>If a client delegates its reporting requirements to a firm and that firm is not a counterparty to a trade, it is important for the LEI of that client to be sent to the APA (e.g. in the case of delegation of post trade processing and reporting).</p> <p>This is because, it is important that when an APA sends publication confirmations back to the firm, the firm will be able to differentiate between its own trades and those of its clients.</p> <p>If such delegation does not take place, this field should be left blank.</p> |
| Transmission time | <p>This is important to ensure compliance with the requirements. It will keep a</p> |

| | |
|--|--|
| | track of the submission of information to the APA, which can then be compared to the publication time. |
|--|--|

The waterfall we are proposing to ensure duplication of publication of trades is avoided is:

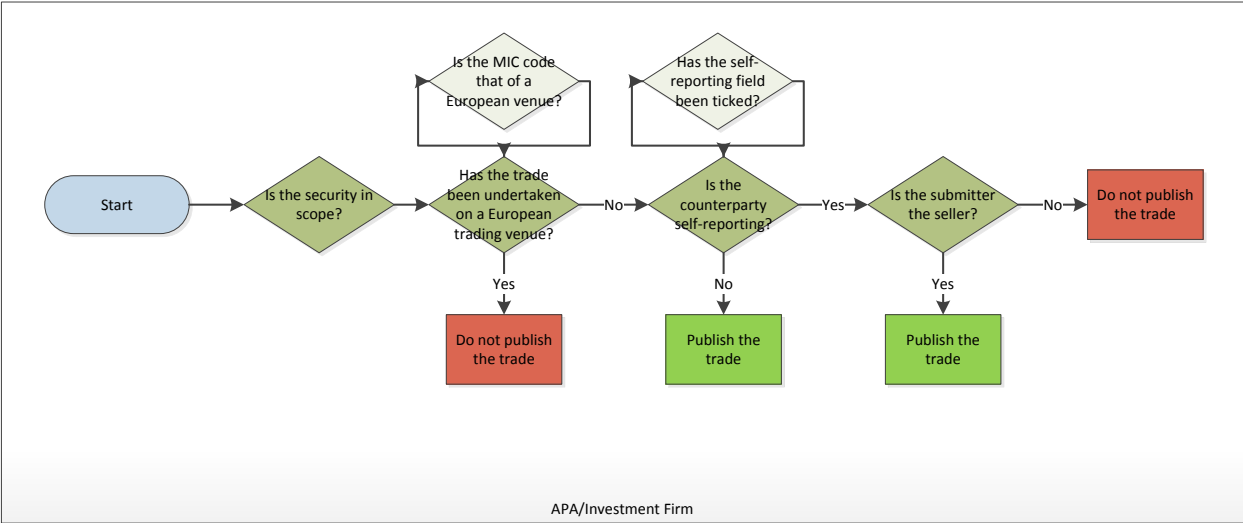
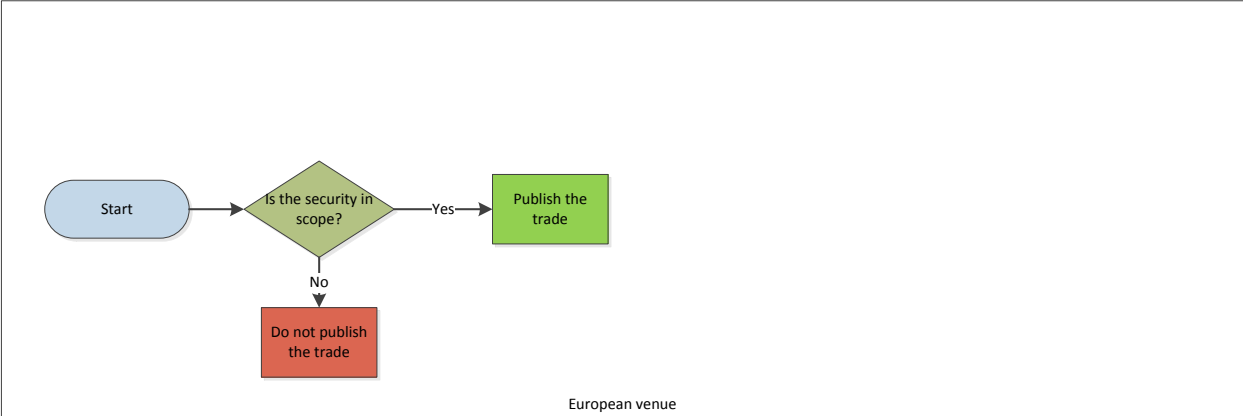

The waterfall ensures duplication is avoided by working as follows: (i) European venues always publish their trades; (ii) if the APA receives a trade from an investment firm and it has been undertaken on a European venue, the APA should not publish the trade (it should suppress it); (iii) if the trade has not been undertaken on a European trading venue, if the counterparty of the submitting investment firm is not a self-reporting entity, then the APA should publish the trade; and (iv) if the counterparty of the submitting investment firm is a self-reporting entity, then the APA should only publish the trade if the reporting investment firm is the seller. If an investment firm does not opt for the APA to apply the waterfall, it must apply the waterfall instead.

<ESMA_QUESTION_132>

Q133: Do you think that the current post-trade regime for shares on the systematic internaliser’s identity should be extended to non-equity instruments or that the systematic internaliser’s identity is relevant information which should be published without exception?



<ESMA_QUESTION_133>

AFME Response

FIXED INCOME

No. AFME does not believe that the equity regime should be extended to bonds and SFP.

AFME believes that of all the proposals ESMA has drafted, this proposal would be the most harmful to the fixed income markets if implemented. The requirement introduces an unlevel playing field between investment firms that are SIs and investment firms that trade an instrument OTC – thereby, introducing perverse incentives that are in direct conflict with the objectives of MiFID II. Further, we believe that these proposals would result in a distorted market whereby investors would be incentivised to trade OTC rather than with investment firms that are SIs.

(i) *The post trade regime should not be extended to provision of the systematic internaliser's identity.*

We strongly believe that a systematic internaliser's identity should not be disclosed on trade reports. We understand that ESMA wishes to provide investors with transparency regarding the most active liquidity pools in a given instrument. However, doing this by publishing the name of the SI alongside each trade will disincentivise provision of liquidity and widen bid-offer spreads, and will therefore be entirely counterproductive to what we believe is the regulatory intent - to reduce transaction costs.

An SI performs a significant and valuable function for investors by providing liquidity in a specific instrument. The SI performs this function through the advancement of its own capital. Exposing the name of the SI in post-trade reports is likely to unveil to third parties the risk that the particular SI has taken in a particular instrument and consequently adversely affect the ability of the SI to manage and unwind that risk. Position information is commercially sensitive and should not be mandated to be exposed to the public: doing so will disincentivise SIs from performing their function in the market.

Liquidity in the bond market is provided almost exclusively by market makers (or “dealers”). These market makers stand ready on a continuous basis to engage in transactions with investors. This means that, instead of engaging in an excessive search for another investor who is willing to buy or sell at a particular point in time, investors turn to a market maker who is the buyer to every seller and the seller to every buyer. The service a market maker provides is “immediacy”, which is the ability to immediately absorb a client's demand or supply into its own inventory. As opposed to a broker, who merely matches buyer and sellers, a market maker itself buys and sells assets, placing its own capital at risk. Typically, an investor will approach several market makers for a price and will transact with the market maker that offers the best price.

Exposing the name of the SI in the post trade reports would unveil to third parties, including competing market makers, the risk that the particular SI has taken in a particular instrument. As such, this would permit other dealers to strategically price against the disclosing SI. In effect, the disclosure of the SI identity exacerbates the “winner's curse” because it identifies the location of the instrument.

If SIs are disincentivised from advancing their own capital, liquidity in relevant financial instruments will naturally decrease, meaning end investors will find it harder to hedge their risks and will face wider spreads when doing so (it will also thereby lead to increased borrowing costs for issuers). By way of comparison, we note that both the CFTC and SEC rules on post-trade transparency expressly prohibit the dissemination of the identities of counterparties to a trade.

Given there may be a time delay in the publication of the price and volume of the transaction for

trades greater than SSTI or LIS or for trades in illiquid instruments, it may be argued that following a delay, the SI identity may no longer be sensitive information. This is not true. Unwinding of risk positions can last a long time (see AFME's response to **DP Question 142**); therefore, even with a delay, it is likely that identity information will be sensitive and an even further delay will be necessary. Further, disclosure of position information will enable market participants to determine the business models of market makers and investors. As a result, it will be more expensive for dealers to commit their own capital to facilitate client trades resulting either in increased costs to investors or a reduction in SIs performing this function, leading to a decline in depth of liquidity.

In terms of the counterargument discussed by ESMA (that the SI quotes are made public and therefore the information is already available), we strongly disagree with the comparison between pre- and post-trade transparency.

- The pre-trade transparency regime for SIs is designed to inform the market of the prices available. It is not intended to give the market an understanding of how many investors have responded to those quotes nor the SI's pattern of execution. A revelation of the SI's identity would have the effect that observers would be able to reconstruct the trading activity of the investment firm, which provided the quotes by revealing all executions it has concluded as an SI. The publication of this information would jeopardise confidential and commercially-sensitive information in respect of the capital advanced by the SI. It may instead provide others with an opportunity to trade in a way that would take advantage of the knowledge that a significant SI has accumulated risk in a particular instrument. Furthermore, this effect would be asymmetric in the sense that the identity of the SI would be disclosed to the market but the identity of the SI's customer would not. This would unfairly benefit the SI's client and the rest of the market at the expense of the SI providing the liquidity.
- The pre-trade transparency requirements for SIs only apply at sizes below the Size Specific to the Instrument in liquid instruments, whereas post-trade transparency will result in trades of all sizes being published regardless of liquidity (either immediately or after the deferral period). This invalidates the comparison between pre- and post-trade transparency.

(ii) We do not agree with a quarterly SI reports

We do not agree that SI quarterly reports are appropriate for bonds and SFPs. Such a requirement would introduce an even greater unlevel playing field between firms that are OTC and those that are SI – an even more onerous SI regime results in greater transaction costs for investors. As a result, there are perverse incentives for investors to trade with investment firms that are OTC in an instrument rather than SI.

If ESMA was to mandate quarterly reports for SI, we recommend that the aggregate reports should be staggered by a quarter. For example, ESMA should not require a Q4 report to be made public in January but in Q2. If ESMA requires the report to be made public the month following the last quarter, not only would it create operational difficulties, but market makers would be more exposed to undue risk in the positions they take on as part of their role of facilitating liquidity in the market at the end of the quarter than the earlier parts of the year (e.g. a Q4 report in January would contain SI exposure information from the last week of December).

<ESMA_QUESTION_133>

Q134: Is there any other information that would be relevant to the market for the above mentioned asset classes?

<ESMA_QUESTION_134>

AFME Response



FIXED INCOME

Yes. AFME believes that there are.

We recommend that certain flags are important to include in the information published as part of post trade publication. These flags serve a number of purposes; for example, to clarify how the price of the trade should be interpreted. Please see our comments in response to **DP Question 135**.

FOREIGN EXCHANGE

The GFXD does not have any further information that is relevant to add.

<ESMA_QUESTION_134>

Q135: Do you agree with the proposed table of identifiers for transactions executed on non-equity instruments? Please provide reasons for your answer.

<ESMA_QUESTION_135>

AFME Response

FIXED INCOME

No. AFME does not agree with the proposed table of identifiers.

We support ESMA mandating the use of trade flags. We believe they serve a number of purposes and are essential to ensuring good quality and meaningful post trade information. However, we believe it is vital for ESMA to clarify how the flags should be used and to reduce as much interpretation and subjectivity as possible.

It is important to learn from the problems that resulted from the equity OTC post trade regime under MiFID I, which was mostly caused by the lack of standardisation, clarity and consistently applied protocols. Further, we should also learn from the solutions that equities market have initiated and implemented to resolve these issues.

We believe that these problems could be even greater in the fixed income market given that the fixed income market is predominantly bilateral trading. Therefore, for fixed income, similar solutions of clarify need to be developed to prevent the issues that arose for the equities regime.

(i) There are two types of flags – informational flags (public) and processing flags (non-public)

We believe it is essential for ESMA to identify the purpose and use of each of the trade flags. By clarifying the purpose, it will streamline the use and standardisation of the flags. It will also enable the industry to be constructive in its feedback on this topic. We recommend that there are two types of flags – public flags and non-public process flags.

Non-public process flags are relevant only when the investment firm opts to have the APA apply the relevant data quality protocols (in part or in full) to ensure non-duplicative publication. Therefore, the non-public flags should only be required if the investment firm does not undertake the waterfall processes in-house (or if it applies the waterfall partially – it should only submit those flags (and fields) that are relevant for the remaining parts of the waterfall). Our proposal on the waterfalls is contained in response to **DP Questions 361 and 132** above. A firm should not be mandated to apply the non-public flag if it applies the waterfall itself.

We recommend that the purposes of these flags could be one or a combination of the following: (i) to clarify the meaning of the price; (ii) to determine whether the trade should be published;

(iii) to determine whether the trade should be included in the liquidity/SI calculations; (iv) to determine or identify or inform the reporting requirements of the trade; and (v) improve the informational quality of the post trade data published.

- i. Clarification of the meaning of the price – due to the nature of some trades, they may appear significantly different from the market price (e.g. they may be a privately negotiated trade with a non-standard settlement). For those interpreting and using the post information, it is important that the reason behind the difference in price is clarified.
- ii. Determining whether the trade should be published – certain trades are not price forming trades and as such should not be published (e.g. technical trades)
- iii. Certain trades are not price forming or would distort the liquidity calculations and as such should be flagged to ensure that they are not included in the ESMA calculations or the SI calculations (e.g. technical trades)
- iv. Determining/identifying/informing the reporting requirements of the trade – these flags are essential for ensuring that either the firm indicates the transparency regime of the trade or for the public interpreting the post trade information.
- v. Improve the informational quality of the post trade data published

Starting point for developing trade flagging for fixed income

ESMA has identified that trade identifiers were addressed in the past by CESR and these identifiers are valid with respect to non-equity instruments. We recommend that the CESR flags are a good place to start but should not be the flags for fixed income. This is because: (i) the fixed income market is different from equities; and (ii) the flags were not sufficient or clear enough for the equities market – therefore, these issues need to be addressed to avoid the issues recurring in the fixed income market.

We highlight that there has been a significant amount of work on trade flagging developed by the equities market with the objective of making trade flags fit for purpose (i.e. for those purposes identified above). One such industry initiative is the Market Model Typology initiative (MMT) - <http://www.fixtradingcommunity.org/pg/group-types/mmt>. MMT is a joint effort by a broad range of industry participants (exchanges, data vendors and reporting venues) and aims to achieve a practical and common solution for standards on post trade equity data. MMT has been based on the CESR 2010 recommendations but translates the recommendations into practical actions. The project was initiated by FESE and is now governed by FIX Protocol. We recommend for ESMA to consider MMT in the development of a trade flagging system for non-equities. We note, however, MMT has been developed for equities and cannot be directly translated to fixed income.

AFME recommends trade flagging standards for fixed income below (we have based this on the CESR recommendations, MMT and fixed income market expertise).

AFME proposed trade flagging system

- i. Hierarchical Data Model

One of the key features of MMT is that there is a hierarchy for trade flagging. The trade flags proposed by ESMA under Table 18, identify the transactions. Prior to identifying the transaction type, it is important to identify the market mechanisms to which the flags apply.

Specifically, MMT has the following hierarchical structure for equities:

MMT Hierarchical Data Model

MMT hierarchical model provides enhanced transparency beyond trade flags

| Level | Type | Code |
|---------------------|---|---|
| 1. Market Mechanism | Central Limit Order Book | '1' |
| | Quote Driven Market | '2' |
| | Dark Order Book | '3' |
| | Off Book | '4' |
| 2. Trading Mode | Scheduled Opening Auction | 'O' |
| | Scheduled Closing Auction | 'K' |
| | Scheduled Intraday Auction | 'I' |
| | Unscheduled Auction | 'U' |
| | Continuous Trading | '2' |
| | At Market Close Trading | '3' |
| | Out of Main Session Trading | '4' |
| 3. Transaction Type | Trade Reporting (On Exchange) | '5' |
| | Trade Reporting (Off Exchange) | '6' |
| | Trade Reporting (Systematic Internaliser) | '7' |
| | (See Slide 7 – MMT Initiative Codes) | 'B', 'X', 'T', 'D', 'N', 'G', 'E', 'P', 'F', 'A', 'C' |
| 4. Publication Mode | Immediate | -- |
| | Non-immediate | '1' |

Source: <http://www.fixtradingcommunity.org/pg/file/fplpo/read/1104772/mmt-initiative-presentation-v20>

With regards to fixed income:

- **Market mechanism** – we believe that the market mechanism is an essential flag to apply before the transaction type. Notably, the pre trade transparency requirements on venue will be dependent on the market mechanism used and as such it is important that it is flagged, so as to ensure the appropriate pre trade requirements as consistently applied.
- **Trade mode** – we do not believe that this is necessary for fixed income
- **Transaction types** – these are important for fixed income and believe they serve the purposes as discussed above – transaction type trade flags are some of those proposed by ESMA under table 18
- **Publication mode** – these flags are important to either ensure that the trade is published in the right way or the trade is interpreted in the right way when made public – these flags are some of those proposed by ESMA.

In our proposal, we also note who AFME recommends applies the trade flags.

AFME proposed hierarchy of trade flags for fixed income:

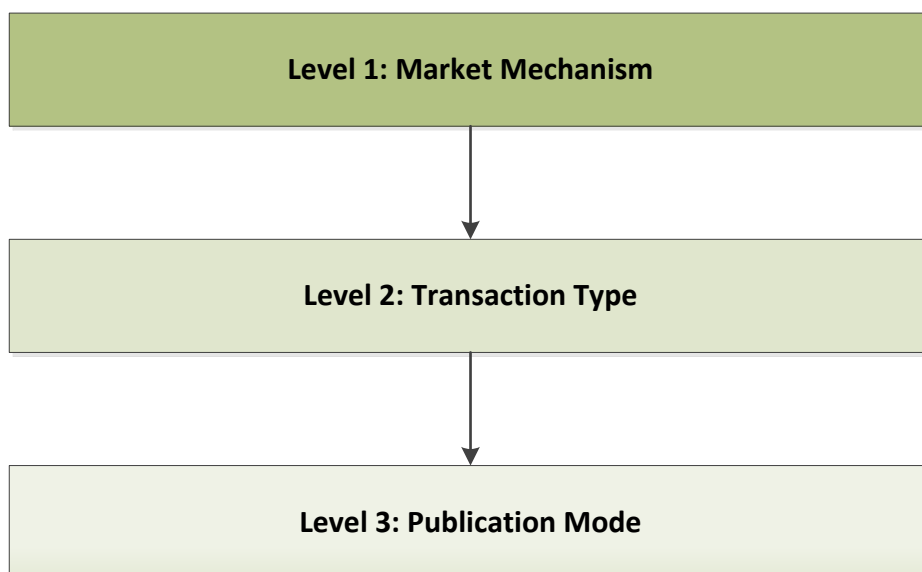

ii. **Market mechanism trade flags**

All flags in Level 2 and 3 will require a flag from Level 1

AFME proposes the following trade flags for fixed income:

- **Continuous auction order book trading system**
- **Quote driven trading system**
- **Periodic auction trading system**
- **Request for quote system**
- **Voice trade system**
- **Venue trading system not covered by the first five rows**
- **Systematic Internaliser trade**
- **OTC trade**

iii. **AFME proposed Transaction Type Trade Flags**

(NB – as above, the process flags only apply to investment firms that opt to use the APA to apply the data quality protocols – if a firm does not opt to use the APA, is should not be mandated to apply the flag)

| Name of trade flag | Definition | AFME comments | Purpose |
|--------------------|---|--|---|
| Technical Trade | Category covering trades which represent non-addressable or trades where the exchange of financial instrument is determined by factors other than the current | AFME agrees with this trade flag but not the definition. However, we note that it is important that it is consis- | <ul style="list-style-type: none"> • Process flag • These trades should not form part of post trade publication |

| | | | |
|--------------------------------------|--|---|---|
| | <p>market valuation of the instrument and is not a price forming trade. Non-exhaustive examples of such trades may include OTC hedges of a derivative, inter-fund transfers, non-equity hedge trades related to the creation/redemption of ETFs, Exchange for Physical Trades and free of payment technical trades for flow purposes and loan conversions.</p> | <p>tently applied and it is important for there to be minimum ambiguity. Therefore, we propose for a clarification that this flag should be used in relation to non-price forming trades. Further, as this is the definition used by CESR for equities, even though the list is non-exhaustive, to provide some guidance, we believe it would be helpful to add fixed income examples.</p> <p>This applies to all market mechanisms</p> <p>It is necessary for the investment firm sending the trade information to the APA populate this flag. The APA will not be in a position to make such a determination. Also, it is important for the members and participants to populate this flag because venues will also not be in a position to make the right determination.</p> | <p>because they are not price forming and do not form part of the price discovery process</p> <ul style="list-style-type: none"> • These trades should not be included in the calculation of the liquidity calibration |
| <p>Non-standard settlement trade</p> | <p>Where there is a need for a participant to match with settlement obligations which may be longer or shorter than the standard settlement cycle.</p> | <p>NEW: This is a new flag proposed by AFME. This is a type of trade that does not correspond with the current market price because it is a privately negotiated trade with a non-standard settlement cycle.</p> <p>Typically, fixed income products are priced assuming standard settlement convention for that class of instrument e.g. standard settlement for gilts is T+1; and for euro governments is T+3 shortening to T+2 in October.</p> <p>For these trades, the investment firm will adjust the price by the cost of carry using the relevant repo rate. This means the price will not be reflective of the standard market</p> | <ul style="list-style-type: none"> • Public flag • To clarify how the price should be interpreted |

| | | | |
|----------------------|---|---|--|
| | | <p>price. It will be important for investors and other market participants to understand that the reason for the price deviating from market level</p> <p>It is necessary for the investment firm sending the trade information to the APA populate this flag. The APA will not be in a position to make such a determination. Also, it is important for the members and participants to populate this flag because venues will also not be in a position to make the right determination.</p> <p>This flag applies to all market mechanisms</p> | |
| <p>Package trade</p> | <p>(1) the Package has two or more components that are priced as a package with simultaneous execution of all components and (2) the execution of each component is contingent on the execution of the other components</p> | <p>NEW: trades that are conditional on other trades will not have the same market price as non-conditional trades.</p> <p>A package is designed to provide desired risk-return characteristics effectively in the form of a single transaction with efficiencies in execution cost and reduction in risk (market and operational) achieved through concurrent execution.</p> <p>Therefore, for the quality of interpreting the post trade information, it is necessary for there to be a flag for these types of trades.</p> <p>It is necessary for the investment firm sending the trade information to the APA populate this flag. The APA will not be in a position to make such a determination. Also, it is important for the members and participants to populate this flag because venues will also not be in a</p> | <ul style="list-style-type: none"> • To clarify how the price should be interpreted • To clarify the deferral in conjunction with the LIS and SSTI flags |

| | | | |
|-------------------|---|---|---|
| | | <p>position to make the right determination.</p> <p>This flag applies to all market mechanisms</p> | |
| Primary trade | <p>Trades in deals with issuing of new securities. Companies, governments or public sector institutions can obtain funds through the sale of new stock or bond issues through the primary market via the process of underwriting.</p> | <p>NEW: For the reasons outlined above, we recommend that primary trades should not be published.</p> <p>Further, as mentioned under DP Question 103, primary trades should not be included in the calculations for liquidity.</p> <p>It is necessary for the investment firm sending the trade information to the APA populate this flag. The APA will not be in a position to make such a determination. Also, it is important for the members and participants to populate this flag because venues will not be in a position to make the right determination.</p> <p>This flag applies to all market mechanisms</p> | <ul style="list-style-type: none"> • Process flag • These trades should not form part of post trade publication • These trades should not be included in the calculation of liquidity of SI |
| Cancellation flag | Transaction cancelled | <p>AFME agrees with this flag. However, it is necessary for the investment firm sending the trade information to the APA to populate this flag. The APA will not be in a position to make such a determination. Also, it is important for the members and participants to populate this flag because venues will also not be in a position to make the right determination.</p> | <ul style="list-style-type: none"> • Public and process flag • To the extent possible, These trades should not form part of post trade publication • Neither the trade being cancelled, nor the original trade which has been cancelled should be included in the calculation of liquidity of SI • This will help improve the |

| | | | quality of the post trade information |
|---------------------------|--|---|---|
| Amendment flag | Transaction amended | AFME agrees with this flag. However, it is necessary for the investment firm sending the trade information to the APA populate this flag. The APA will not be in a position to make such a determination. Also, it is important for the members and participants to populate this flag because venues will also not be in a position to make the right determination. | <ul style="list-style-type: none"> • Public and process flag • To the extent possible, These trades should not form part of post trade publication • Only the originally published trade as amended should be included in the calculation of liquidity • This will help improve the quality of the post trade information |
| Temporary suspension flag | When temporary suspension has been applied | This should be a non-public flag to ensure that trades subject to temporary suspension submitted to APAs are not published | <ul style="list-style-type: none"> • Process flag • To ensure that the trade is not published |

iv. AFME comments on the ESMA Transaction Type flags not discussed above

- **Benchmark trade flags** – this flag should not be included as a flag for fixed income. It is equities-specific and is not relevant for fixed income. This is not the way price is calculated in the fixed income markets.
- **Agency cross trade** – We do not consider this flag should be included, on the basis that it would not offer sufficiently meaningful information to the market so as to justify the build cost of including such identifiers in trade reports.
- **Give up/give in flags** – this is not relevant for fixed income

First, we do not agree that the current definition is an appropriate definition of give-up/give-in trades. In any event, even if the ESMA definition of give-up/give-in trades were adopted, a flag would not be necessary. ESMA defines the give-up/give-in flag to be “*all transactions where an investment firm passes a client trade to, or receives a client trade from, another investment firm for the purposes of post-trade processing*”. In the event a client uses a firm for post trade processing, a flag that this occurred will not provide any value: (i) there has only been one trade and there is no risk of double reporting, so it is not necessary for the purposes of avoiding duplicative reporting; and (ii) it does not impact the price of the trade so provides further value in the interpretation of the price information.

Second, MMT does have a flag for give-up/given-in trades for equities, which has the following definition: “*a trade that has resulted from an order having been executed by a broker on behalf*”

of another broker. A give up (or give in) trade means that the broker who executed the trade must give-up the commission for executing that trade to the other broker”. As far as we are aware, such a flag is not relevant for bond/SFP trades.

v. Publication flags

We agree that there should be publication flags. However, we do not agree with those proposed by ESMA.

| Identifier | Name of trade flag | ESMA definition | AFME comment on the definition |
|------------|--------------------------------|--|---|
| L | Large in scale | Transactions executed under the pre trade large in scale waiver. Not necessarily both sides of the transactions will be large in scale | <p>We believe that this flag should relate to trades that are subject to the post trade large in scale deferral.</p> <p>We do not agree that there is informational value in identifying if a trade has been subject to the pre trade waiver. We do not understand the informational value in reporting whether a trade (post trade) has been subject to a pre-trade large in scale waiver.</p> |
| I | Illiquid instrument trade flag | Transactions entered under the waiver for instruments for which there is not a liquid market | We agree with this flag |
| S | Specific size trade flag | Transactions entered under the waiver for actionable indications of interest in RFQ and voice trading systems that are above a size specific to the financial instrument | <p>We believe that this flag should relate to trades that are subject to the post trade size specific deferral.</p> <p>We do not agree that there is informational value in identifying if a trade has been subject to the pre trade waiver. We do not understand the informational value in reporting whether a trade (post trade) has been subject to a pre-trade large in scale waiver.</p> |

vi. Other MMT flags that are not relevant for fixed income

For reference, we note that there are other transaction type flags present under MMT that are not relevant for fixed income. To clarify, the following flags should not be applied to fixed income:

- Negotiated trade flag
- Ex/cum dividend flag



FOREIGN EXCHANGE

As we have previously discussed, the GFXD promotes global harmonization in regulatory obligations. We suggest that in-order to promote global consistency, that some of the flags identified in Table 18 (Flags proposal) on page 159 of the Discussion Paper are more relevant to FX than others. We support the inclusion of the ‘cancellation’ flag, the ‘amendment’ flag and maybe suggest that a ‘new’ flag identifying new transactions should additionally be included. The GFXD does not support the inclusion of the other flags.

<ESMA_QUESTION_135>

Q136: Do you support the use of flags to identify trades which have benefitted from the use of deferrals? Should separate flags be used for each type of deferral (e.g. large in scale deferral, size specific to the instrument deferral)? Please provide reasons for your answer.

<ESMA_QUESTION_136>

AFME Response

FIXED INCOME

Yes – AFME supports the use of flags to identify trades which have benefitted from the use of deferrals. However, we do not agree with the flags proposed by ESMA. Please see our response to **DP Question 135**.

FOREIGN EXCHANGE

The GFXD does not support the use of flags for deferrals. The trading time is one of the fields that is required to be published and that should be sufficient for the market to calculate if a trade is deferred.

<ESMA_QUESTION_136>

Q137: Do you think a flag related to coupon payments (ex/cum) should be introduced? If yes, please describe the cases where such flags would be warranted and which information should be captured.

<ESMA_QUESTION_137>

AFME Response

FIXED INCOME

No. As mentioned in answer to Question 136, AFME does not believe flags related to coupon (ex/cum) payments are necessary.

In fixed income, only the clean prices are reported (e.g. fees, accrued interest etc are excluded); therefore, the ex/cum is irrelevant.

FOREIGN EXCHANGE

The GFXD does not support the use of flags for deferrals. The trading time is one of the fields that is required to be published and that should be sufficient for the market to calculate if a trade is deferred.

<ESMA_QUESTION_137>

Q138: Do you think that give-up/give-in trades (identified with a flag) should be included in post-trade reports or not made public? Please provide reasons for your answers.

<ESMA_QUESTION_138>

AFME Response

FIXED INCOME

No. We do not believe these flags are necessary.

As explained in our response to Question 136, give-up/give-in flags are not useful because the trade is never published twice and there is no informational value to the flag. Such transfers should not be required to be trade reported at all, given that they are not price forming transactions.

FOREIGN EXCHANGE

For FX, the GFXD believes specificities inherent to a prime brokerage (PB) relationship should be taken into account when considering if trades should be reported. The industry is currently actively engaged in achieving a model suitable for prime brokers as the CFTC is again consulting on PB issues. In order to avoid the similar intricate and time-consuming process engaged by the industry in the US in order to obtain the CFTC relief, we urge the regulator to consider the prime brokerage framework when finalising the rules on post trade reporting under MiFIR.

It should be noted that PBs reporting stale pricing data to the public was a key consideration in the CFTC's decision to issue the no action relief letter #12-53 dated December 17, 2012 (<http://www.cftc.gov/ucm/groups/public/@lrlettergeneral/documents/letter/12-53.pdf>) under which PBs have no real time public reporting obligation as long as that responsibility is allocated to an Executing Broker (EB) that is registered with the CFTC. Although the CFTC no action relief letter was time limited and expired a year ago, without being renewed, we believe that market participants in the U.S. who are engaged in prime brokerage transactions continue to follow the principles laid out in the letter pending a renewal of the letter or a substantive regulation to the same effect.

We explain below the 4 main FX prime brokerage structures: traditional, reverse give up, 4-way and customer to customer (C2C).

FXPB traditional structure

The traditional FX prime brokerage structure allows clients of a prime broker (PB) to enter into trades on behalf of a PB (within the limits set-up by the PB) with pre-approved executing brokers (EBs) that have been notified of the applicable limits per client.

Because the trades are known by the PB only once given-up to the PB (usually by the end of the same business day NY time and following notices from both the client and the EB), the PB is not able to report the trade in a real-time fashion, but certainly on the following business day. This means that the data reported by the PB would be stale, which may undermine the price discovery objectives of the MiFIR reporting regimes.

Under this structure, the EB will however have to report the trade (as it is an investment firm).

Similar concerns with PBs reporting stale pricing data led to the CFTC granting a time limited exemption waiving the real-time reporting obligations on PBs as far as the Mirror Trade is concerned (please see our general comment below).

Also, one should take into account that simultaneously to the acceptance by the PB of a give-up trade, an offsetting trade between the PB and its client is executed, the "Mirror Trade". The issues we see here is also that the data to be reported would be stale, because the price is the one

agreed under the give-up trade, it does not reflect the market conditions at the time the Mirror Trade is entered. The result would falsely indicate the occurrence of two pricing events and incorrectly suggest the presence of more trading activity in the market than actually exist. Similar concerns with PBs reporting stale pricing data led to the CFTC granting a time limited exemption, waiving the real-time reporting obligations on PBs as far as the Mirror Trade is

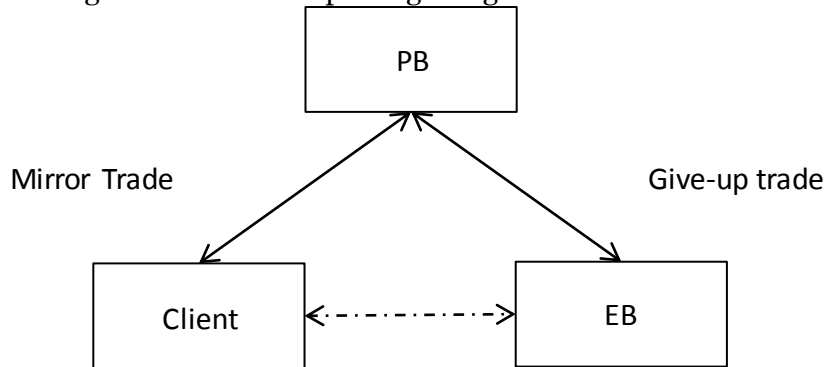

concerned.

Reverse Give-up FXPB agreement

A reverse give-up relationship introduces a fourth party to the prime brokerage relationship (another PB). Upon the PB client's instruction, the first PB (PB1) will reverse give-up part or all of a Give-up trade to the second FX Prime Broker (PB2).

Whereas the traditional FXPB structure involves 2 trades, under the RGU structure there will be either 3 or 4 (in case of partial allocation) trades, as follows:

1. PB1 vs EB (Give-up trade)
2. PB1 vs PB2 (Give-in trade)
3. PB1 vs PB client– in case of partial allocation only (Mirror trade)
4. PB2 vs PB client (Mirror trade)

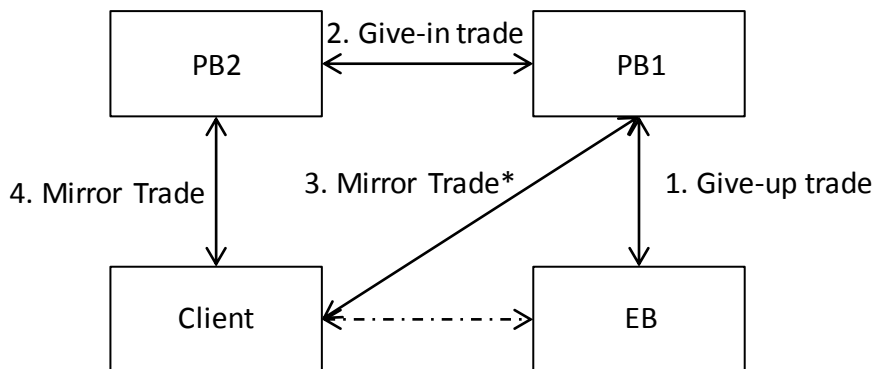

* In case of partial allocation only

Comments on trades 1 and 3 are the same as under the traditional PB structure. Trades 2 and 4 will be executed only once the PB client notified PB1 of its intention of allocating the trade to another PB and after the trade 1 is given-up, so once they could be reported their price would be stale.

Four Way FXPB agreement

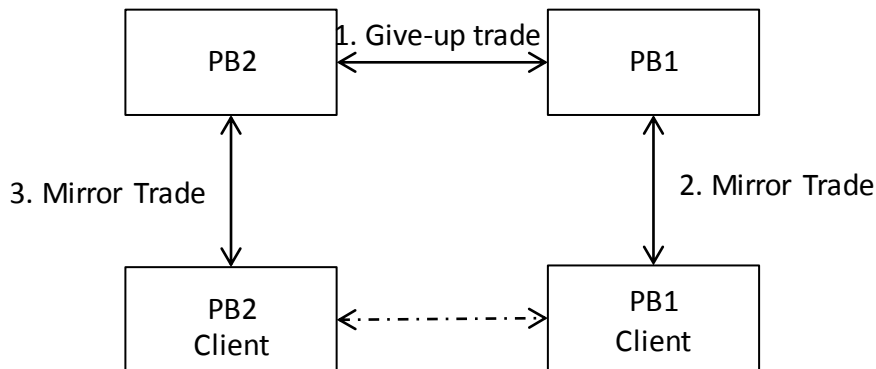

Under a Four Way agreement a PB client of PB1 enters into a trade directly with a PB client of PB2, and they both give-up the trade to their respective PB.

In this structure the Give-up trade cannot be real-time reported if none of the PB clients are investment firms. As to the PBs, they will be in a position to report the trade only once they receive the notification of the trade from their respective client (timing to be agreed under their respective PB agreement) and after having checked against each other that the notices match. This process will therefore imply a reporting of data that are stale.

Customer to Customer FXPB agreement

Under a customer to customer agreement two clients of the same PB enter directly into a trade, and then give-up the trade to the PB. Similarly to the Four Way agreement there are three trades involved: the Give-up trade and two Mirror trades.

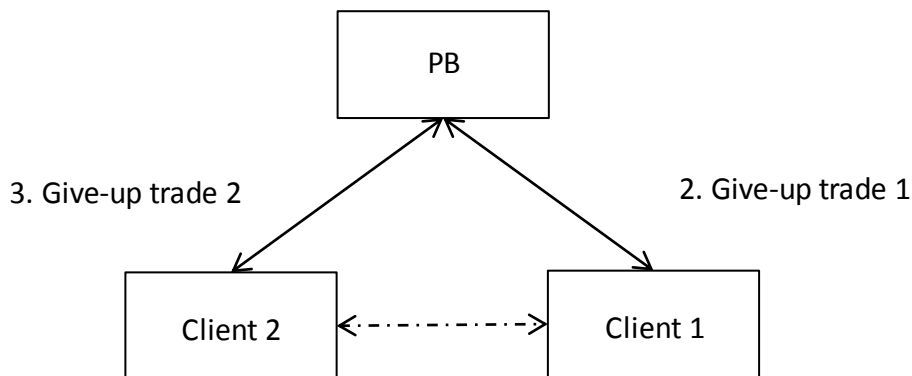

<ESMA_QUESTION_138>

Q139: Do you agree that securities financing transactions should be exempted from the post-trade transparency regime?

<ESMA_QUESTION_139>

AFME Response

FIXED INCOME

Yes. AFME agrees that securities financing transactions should be exempted from the post trade transparency regime. We also ask ESMA to clarify that it intends for securities financing transactions to remain out of scope of the equities post trade regime.

<ESMA_QUESTION_139>

Q140: Do you agree that for the initial application of the new transparency regime the information should be made public within five minutes after the relevant non-equity transaction? Please provide reasons for your answer.

<ESMA_QUESTION_140>

AFME Response

FIXED INCOME

No. AFME does not agree with ESMA’s proposal.

We believe a five minute reporting period for real time publication is inappropriate for fixed income. We recommend a 15 minute publication period for real time.

We note there are some transactions (e.g. voice trades) may require longer (e.g. 30 minutes) to comply with the regime.

(i) A five minute publication period for “real-time” is inappropriate for the fixed income markets

ESMA has recognised in paragraph 34 that the fixed income markets largely rely on manual functionalities and processes that may affect the time required for publication. We agree with ESMA’s statement, especially for bilateral trading, and recommend that as a result of the necessary manual functionalities of the fixed income market, for the majority of trades, a five minute period is too short and is unachievable for the publication of trades (which involve the following processes: booking of trades, internal processing, submission to the APA, APA processing and publication of trades). Even if firms and APAs managed to achieve the five minute period, the resulting post trade data will be of poor quality – for example, the data may be incorrectly flagged, absent of the right validation, fields could be incorrectly populated, published trades may be cancelled and amended moments later and published trades could be duplicative.

ESMA is currently proposing for the following process to be completed within five minutes:

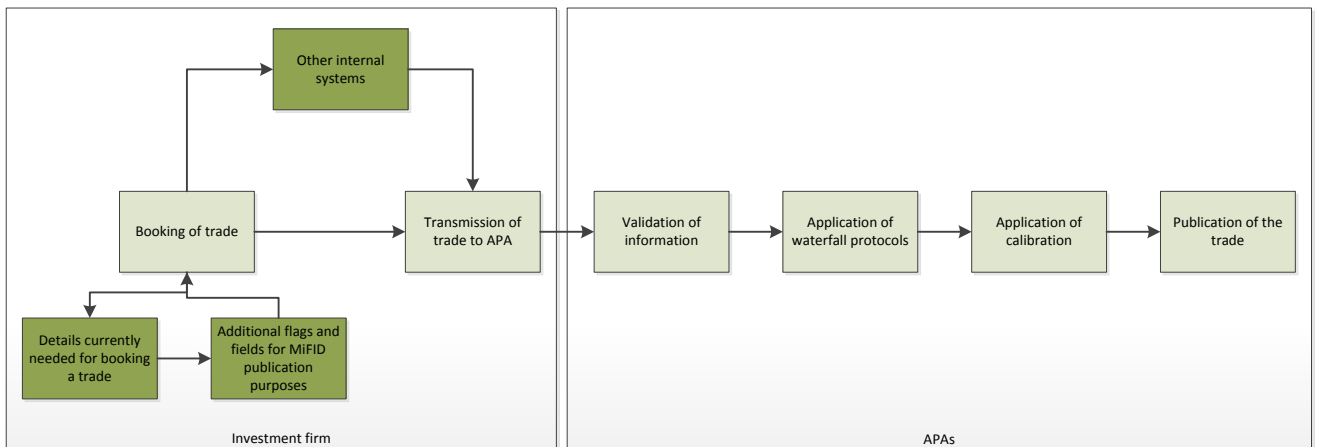

ESMA should note that there are many processes that need to take place before publication of the trade. These many processes will create a time lag and even if they are automated will involve checks/queries/reconciliation, which take time. For example, the transmission of the trade to the APA can be automated but five minutes does not give time for any meaningful validation, which is one of the APA functionalities proposed by ESMA under Section 5.1 (e.g. if the APA queries a price in the validation process, there needs to be sufficient time to complete the rele-

vant checks and corrections). Ultimately, five minutes does not give sufficient time for meaningful completion of necessary processes and will result in large number late printed trades.

As mentioned above, in fixed income, the booking process is largely manual, especially for off-venue trades, which can take a material amount of time. Information such as the correct counterparty identifier, the settlement date etc, are all populated at booking. Further, some trades require more time than others for booking. For example, trades which contain multiple legs all need to be booked separately. A five minute publication period will result in firms inevitably failing to meet their publication requirements (ESMA notes that TRACE with a 15 minute publication limit has a 20% failure rate).

Under the new MiFID II regime, there will need to be more fields and flags populated at booking, which involves subjectivity by the trader. If the booking time is reduced to a matter of a couple of minutes, it is likely that there will be a greater number of errors and inconsistencies in the data set, resulting in poor quality post trade data. For example, in order to ensure that the deal is booked correctly and for the purposes of ensuring that the correct post trade waterfall protocol is applied, the dealer needs to book the trade under the correct counterparty in terms of specific legal entity. We urge ESMA to aim for higher quality post trade data that is meaningful to its users through consistently applied standardised protocols rather than excessively fast publication which will result in poor quality data.

Further, the problem of data quality will be even further exacerbated by the excessively short time frame for publication as a result of the fact that many trades are cancelled and amended. The graph below demonstrates this – it shows of all cancelled/amended trades that are reported through TRAX, over the course of three days in the week of 7 July 2014, the proportion of those cancellations/amendments that occurred within 5 minutes, 15 minutes, 30 minutes, 1 hour and 5 hours from the time of execution of the trade. The graph illustrates that a significantly greater proportion of cancellations and amendments are captured the longer the real-time limit is. For example, if the real time limit is 5 minutes, 17% of cancellations /amendments are captured – meaning 83% of cancellations/amendments could occur after publication. However, if the real time limit is 15 minutes, approximately, 30% of cancellations/amendments are captured, increasing the quality of the published data.

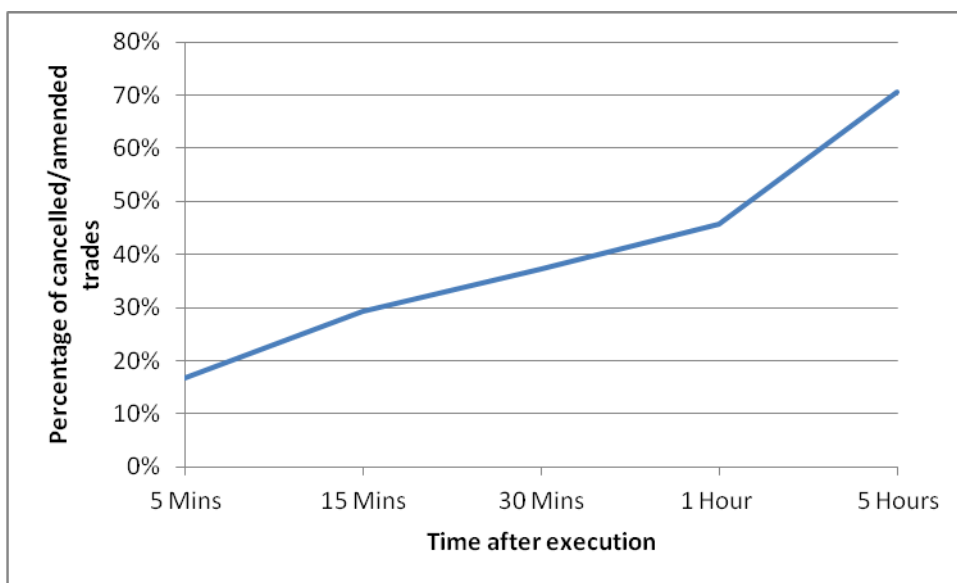

Source: TRAX

ESMA itself notes that the fixed income market is not a highly liquid market; therefore, we question the value of a five-minute reporting period over better quality data for users.

Finally, matching is an important part of the lifecycle of a transaction: there are three steps – confirmation, affirmation and allocation. Transactions that are matched facilitate the client allocation process and enables transactions to be settled with the client more quickly by resolving inconsistencies in an automated fashion. The matching process is as follows:

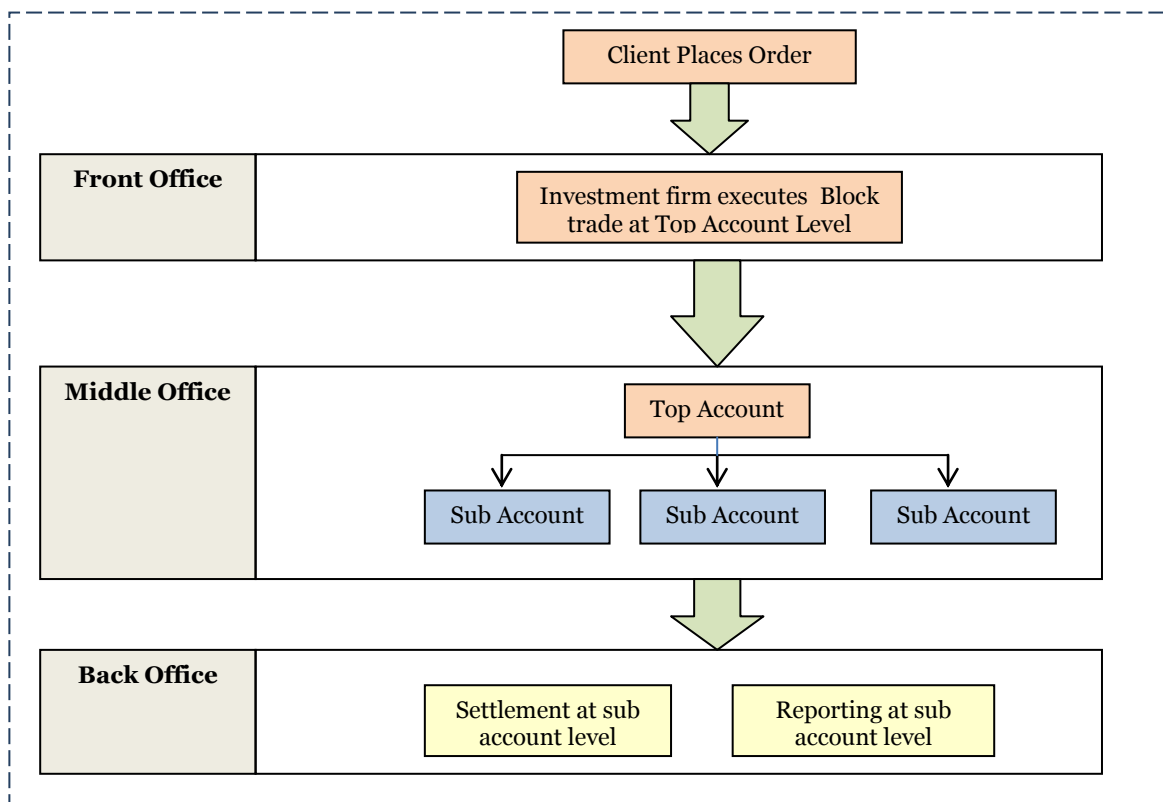

A shorter real-time publication requirement will result in fewer matched trade being published – meaning poorer quality data. We would urge ESMA to introduce a regime that results in as many published trades as possible having been matched.

(ii) A limit of 15 minute publication period for “real-time” should be adopted

AFME recommends that a 15 minute real-time publication period should be adopted, for the following reasons:

- A 15 minute publication period is a more achievable time period for resolving the issues (outlined above).
- The US TRACE system has a 15 minute post trade publication requirement – we strongly suggest that ESMA ensures operational consistency (as far as possible) between the US and Europe. Operational consistency will enable firms to leverage off their existing publication systems, which will reduce the cost of implementation on an initial and ongoing basis, which will reduce the end costs to investors of the MiFID regime. Also, global operational consistency will ensure that firms trading in Europe are not at a disadvantage to US counterparts due to an unlevel playing field.
- A 15 minutes rather than five minute reporting period will significantly increase the quality of the data with very little detriment to the usefulness of the data from a price discovery

perspective. To reiterate, the fixed income market trades fairly infrequently (see table below – showing most bonds trade less than once a day); therefore, a ten minute longer time period will not change the value of the data. However, we stress that poor quality data will have more significant adverse impacts on the usefulness of the data.

% ISINs (for each month) traded within monthly number of transactions categories for the period 1 July 2010 to 30 June 2011¹⁴

| Asset Class | % ISINs (for each month) traded within ‘monthly number of transactions’ categories | | | | | |
|------------------|--|--------------|---------------|---------|----------------|-------------|
| | < 20 trades | 20-50 trades | 50-100 trades | 100-200 | 200-400 trades | >400 trades |
| Government bonds | 7.60% | 1.32% | 7.82% | 22.95% | 29.97% | 30.34% |
| Supranationals | 48.19% | 24.84% | 15.88% | 8.33% | 2.44% | 0.31% |
| Corporate bonds | 63.80% | 21.13% | 10.10% | 4.38% | 0.59% | 0.00% |
| Covered bonds | 82.17% | 14.33% | 2.96% | 0.47% | 0.00% | 0.08% |
| High Yield | 53.83% | 32.33% | 10.42% | 2.50% | 0.92% | 0.00% |
| Securitisation | 99.70% | 0.30% | 0.00% | 0.00% | 0.00% | 0.00% |

Source: nine investment firms

We do highlight that we would encourage firms and venues to use the 15 minutes period as a maximum limit and try to publish sooner in all cases.

(iii) The real-time limit should be phased in

ESMA could consider introducing a regime that allows for gradual implementation. The risks associated with price transparency can be mitigated if the transparency requirements are implemented gradually. This would allow for the market impact to be studied and the calibration to be adjusted if required. It would also enable market participants to prepare the operational requirements of the framework.

We would propose for real time publication to start with a time limit of 60 minutes following implementation of MiFID II. This should then be brought down to 30 minutes and then down to 15 minutes. A similar approach was followed in the US when price transparency was introduced under TRACE (Trade Reporting and Compliance Engine).

<ESMA_QUESTION_140>

¹⁴ Trade data for a random sample of 608 ‘traded’ ISINs over the period 1 July 2010 to 30 June 2011 was used for the back-testing analysis. See: <http://www.afme.eu/WorkArea/DownloadAsset.aspx?id=6821> for the full report.

Q141: Do you agree with the proposed text or would you propose an alternative option? Please provide reasons for your answer.

<ESMA_QUESTION_141>

AFME Response

FIXED INCOME No. AFME does not agree with the proposed text.

AFME agrees with ESMA (under paragraph 55) that the higher the minimum qualifying size the longer the permitted deferred period. However, we do not agree that for bonds and SFPs that there should be a different treatment on an asset class by asset class basis. However, we stress that for bonds and SFP, an IBIA approach should apply based on the issue size category.

We do not agree with ESMA that the size specific threshold and large in scale threshold should only apply to liquid instruments. The conditions under MiFIR Article 11 are not stated to be mutually exclusive.

MiFIR Articles 11 and 21 provides that all the details of the trade may be deferred in circumstances where there is a large in scale, a trade in an illiquid instrument or a trade above a size specific to the instrument. Publication of volume information may be allowed for an extended time period of deferral based on thresholding of the aforementioned conditions. We note that ESMA has not proposed a regime that adopts these principles set out under MiFIR. We urge ESMA to reconsider these principles and adopt a regime that incorporates this framework set out under MiFIR.

We also do not agree that the size specific threshold for liquid instruments could be similar to the time period of deferral proposed under the large in scale regime for equities (as suggested under paragraph 53). We stress that the equities market and fixed income market are not comparable. Even liquid instruments for fixed income are not highly liquid and are not comparable to equities. Generally, the equities market is highly liquid and predominantly trades on lit order book in small sizes.

The fixed income market requires market makers to take on risk to facilitate client trades. As such, in fixed income, if a market maker does not have sufficient time to hedge or unwind its position, then it will be exposed to undue risk. Therefore, we strongly recommend that the delay for the size specific to the instrument whereby it would cause undue risk to the liquidity provider and the large in scale threshold is sufficiently long to prevent the undue risk materialising. The undue risk in fixed income is the winner's curse. Therefore, the deferral regime needs to be calibrated to the risk – the winner's curse.

In the market maker model, transparency can create a winner's curse, making it costly for dealers to hedge their positions and unwind their risk. This works as follows. After a market maker executes a transaction with an investor, they enter the interdealer market to hedge their risk. Even after hedging their risk, they will hold on to a certain level of credit risk (the larger the size of the position, the greater the risk), over time they will unwind that position and risk. However, if the trade is made public before the market maker can hedge and unwind his risk position, other dealers can benefit by taking up contrarian positions in the interdealer market, thereby making it difficult for the successful bidder to offset the risk of the position. Market makers will need to compensate for this risk of adverse price movements by increasing the transaction costs that they charge to investors. Investors will require compensation for these increased costs from the issuers of bonds (governments and companies), in the form of higher borrowing costs. Therefore, an appropriate time delay for price publication and extended delay of the volume sufficient to permit hedging and unwinding of risk prevents these adverse effects.

Winner's curse

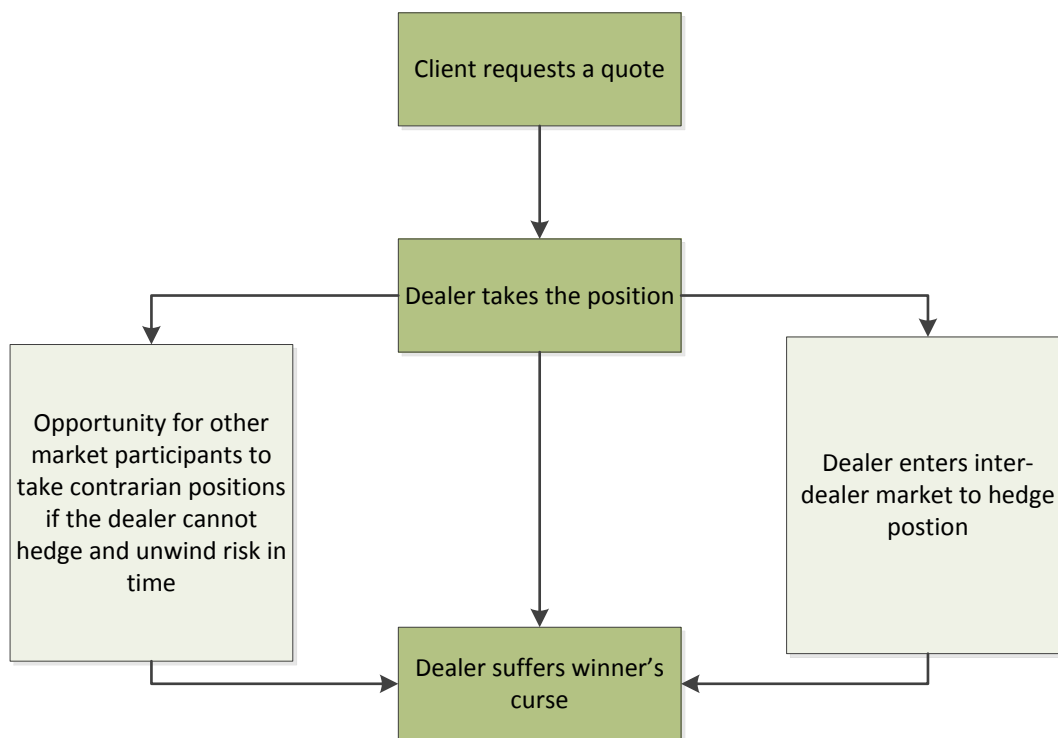

- Transaction costs for investors increase
- Borrowing costs for issuers increase

Hedging and unwinding risk

When a market maker takes on a risk position, there are three important types of risks that need to be considered: the interest rate risk, the credit risk and the issue specific risk. Issue specific risk remains with the market maker until the position has been completely unwound; it is the risk to the market maker in the event his position is known and other dealers move against him prior to being able to unwind the position.

There are three main ways in which interest rate exposure can be hedged: (i) a futures trade; (ii) a government bond trade; and (iii) a swaps trade. These are described below.

Execution time of the hedge depends on the instrument that needs to be used. The less depth there is in the market, the longer the hedge takes. We also note that there is no such thing as a perfect hedge.

With regards to the credit risk that the market maker is exposed to when it takes on a position, there are three ways in which the market maker offsets its position: (i) via an equivalent credit risk bond trade; (ii) via a CDS trade; and (iii) unwinding the risk position by selling the bond.

Hedging and unwinding risk positions can take a significant amount of time because the fixed income market does not have a lot of depth. Further, the time taken for hedging and unwinding of credit risk increases as either the trade size increases (whether or not the bond is liquid) or the liquidity of the instrument decreases.



We strongly oppose the ESMA proposed deferrals. We believe that they are inappropriate for the fixed income market and believe they are too short to serve the purpose for which they are intended – to mitigate undue risk to liquidity providers (i.e. market makers).

<ESMA_QUESTION_141>

Q142: Do you agree that the intra-day deferral periods should range between 60 minutes and 120 minutes?

<ESMA_QUESTION_142>

AFME Response

FIXED INCOME

No. AFME does not agree with an intra-day period for volumes.

- (i) *AFME agrees with the proposed deferrals for price information (the lower end proposed by ESMA)*

We note that we do not agree with the real time limit set as 5 minutes from the time of execution (please refer to our response to **DP Question 140**).

- (ii) ***AFME does not agree with the deferrals for volume information for trades greater than LIS and trades in illiquid instruments***

The time periods for volume omission proposed by ESMA are too short and, as such, we propose extending these to the degree necessary to ensure that market makers have sufficient time to hedge their positions and protect themselves from the risks they take by providing liquidity to the market. We propose that for transactions above large in scale, for an extended deferral to apply, which would be 6-12 months.

We believe that the proposal conflates the provisions of Article 11(1) of MiFIR, which permit deferred publication of any trade details based on the size or type of transaction, with Article 11(3)(b) of MiFIR which permits, in conjunction with an authorisation of deferred publication, the omission of the volume of an individual transaction during an extended time period of deferral. The proposed text takes a very limited view of what constitutes an "extended" time period of volume omission as permitted by Article 11(3)(b) of MiFIR.

In particular, it is vital that the size of transactions in illiquid instruments and liquid instruments when traded above the LIS threshold are masked for an extended period of time. Whilst we appreciate that ESMA does not have the power to permit an indefinite masking of size (as per the US CFTC regime) we would urge ESMA to exercise its powers pursuant to Article 11(4)(d) of MiFIR to provide for the masking of trade size for a sufficiently long period of time to ensure that liquidity providers can de-risk effectively. In many illiquid markets it can take several months for liquidity providers to hedge/unwind their exposures and, in liquid markets, large trades are often only proxy-hedged initially, then warehoused by liquidity providers for significant periods of time. It can take weeks or months to fully exit such positions. The inability to de-risk before the size of a LIS or illiquid trade is made public will act as a significant deterrent to the provision of liquidity.

For price formation purposes there is little value to general market participants in knowing the exact size of a trade, particularly compared to the adverse consequences to liquidity providers of excessive transparency of trade size. It should be sufficient for the market to know that a large or illiquid trade has taken place and this can be achieved by including an appropriate "flag" when the other details of the trade are published after the initial, shorter, deferral period.

In addition to ensuring that market-makers and other liquidity providers have sufficient time to

hedge their exposures, there are other reasons why an extended time period of deferral is needed in respect of volume. There are circumstances in which the publication of trade size may contribute to market instability. A planned cross jurisdictional, cross currency acquisition is a practical example of this. Such transactions have significant exchange rate risk and it is common for the take-over to be preceded by large foreign exchange forward transactions (sometimes conditional on completion of the transaction) some days or weeks in advance of expected finalisation of the take-over. In the absence of extended volume omission, a very large foreign exchange transaction would be published, which would give rise to rumour and speculation, could result in distortion of other market prices, and could even imply a leakage of material non-public information. The period of volume omission needs to extend at least beyond the typical tenors of these transactions. Similarly, pre-hedging of new bond issues can give rise to activity in interest rate swaps, and large trades being published post-trade without volume omission would give rise to rumour, speculation and ultimately market instability.

We believe that a 6-12 month delay is appropriate for a number of reasons:

- 6-12 months would provide market makers with sufficient time to hedge/unwind their risks in large and/or illiquid trades. As discussed in response to **DP Question 141**, the larger the size and/or the more illiquid the trade, the more difficult it is to hedge/unwind risk. More often than not, trades take more than a day to hedge positions/unwind risk. Very often, the risk of a trade can take months to unwind. We stress, again, it is essential that ESMA adopts a risk-based calibration that is fit for purpose.
- To demonstrate the many months that it could take to unwind a risk position, AFME has analysed TRAX data¹⁵. The analysis involved calculating the length of time it took investment firms to unwind positions from the date of a trade (based on its buy/sells). Only entities submitting data to TRAX were considered (to ensure that investors, which are typically buy-to-hold, were not included in the calculations - this would cause distortions). The test sample was comprised of 729 corporate bonds. AFME would be happy to discuss its methodology further.

| <= 1 day | >1 - 30 days | 31 - 90 days | 91 - 180 days | 180+days |
|----------|--------------|--------------|---------------|----------|
| 21% | 24% | 16% | 9% | 29% |

Source: TRAX

We note that AFME's calculations are work-in-progress and are imperfect. One significant

¹⁵ AFME has undertaken testing on trade data provided by TRAX. 10,091 traded fixed income bonds were randomly chosen from six asset classes (government bonds, supranationals, corporate bonds, high yield, covered bonds and securitisation). Trade data for these securities was tested over the period 1 October 2011 to 30 September 2013. Given that these securities were chosen at random, we can assume that this universe is proportionally representative.

clarification regarding the data is it includes trades undertaken for the treasury departments of the reporting investment firm. Treasury departments are typically buy-to-hold. As such, we would assume that the majority of the positions relating to the longest holding period are treasury department trades and not dealer trades. As such there are distortions in the data, which AFME will continue to work on.

The results clearly indicate that only 21% of trades are unwound in a day. This demonstrates intraday volume transparency and this is most likely to be the smaller size liquid trade population. Further, 62% of trades are unwound in 90 days. The data clearly demonstrates (despite the caveats) that unwinding of risk takes weeks/months rather than minutes.

- We note that in the US, the TRACE reporting system, the volume information for block trades (greater than USD 5mm for investment grade corporates and USD 1mm for high yield bonds) are deferred by 18 months. A deferral of 6-12 months would be broadly consistent with the principles in TRACE – ensuring greater levels of global harmonisation.

We note that under MiFIR Article 21(4) competent authorities may allow the publication of several transactions in an aggregated form for the period of deferral for indefinitely for sovereign debt. As such, if ESMA does not wish to implement a regime with involves deferrals of many months, whereby no volume information (other than a LIS flag) is published; it has the option to consider a regime where aggregated information is provided in the period of the deferral. We note that aggregation, however, is only workable when there are sufficient trades to aggregate (i.e. if there has only been one trade, it cannot be aggregated).

(iii) ***AFME proposal for delays for liquid instruments***

We propose the following time delays (please note that as per our proposal under **DP Question 112**, we propose an issue size based approach):

For instruments with an issue size EUR >=5bn & 500mm-5bn

Superliquid & liquid

| Size of transaction | Deferral period | Details to be published after the deferral period |
|---|--|--|
| Size is below the threshold for size specific to the instrument and large in scale | N/A | Publication of all details as close to real time as is technically possible and no later than 15 minutes |
| Size is equal or above size specific to the instrument but below large in scale threshold | 60 minutes all details | All details to be published after the deferral period is over |
| Size is equal or above large in scale threshold | Price: 120 minutes Volume extended delay: 6-12 months | Price to be published after the delay with an indication that the size is above LIS Volume to be published after the extended delay |

As discussed in response to **Question 112**, instruments with issue sizes equal to or less than EUR 500mm in size should be treated as illiquid.

(iv) **Details to be published during the deferral period if requested by the Competent Authority**

We highlight that there could be inconsistencies across different EU jurisdictions if different competent authorities apply different regimes. This would introduce an unlevel playing field across the EU. Further, it could disincentivise cross-jurisdictional transactions on the basis that the trade in one jurisdiction could require no time delay and another could permit a longer delay and introduce difficulties in achieving a good quality data set as firms may not be able to delegate their reporting requirements because their jurisdiction require different regimes.

Such an inconsistent approach will introduce operational difficulties to achieving non-duplicative, high quality public data (since different firms will be subject to different requirements). We strongly recommend a harmonised approach.

<ESMA_QUESTION_142>

Q143: Do you agree that the maximum deferral period, reserved for the largest transactions, should not exceed end of day or, for transactions executed after 15.00, the opening of the following trading day? If not, could you provide alternative proposals? Please provide reasons for your answer.

<ESMA_QUESTION_143>

AFME Response

FIXED INCOME

No. AFME does not agree with ESMA's proposal

Market makers can require weeks or months not days to hedge/unwind their risk. We refer to our response to **Question 142** for reasons and our alternative proposal. We strongly disagree with the time delays for the publication of volume information – intraday deferrals are not a meaningful delay. We propose a 6-12 month delay.

FOREIGN EXCHANGE

For FX, the GFXD would like to propose a modified version of ESMA's proposal which is reflected in Table 14 below. The key changes we would like to suggest are:

- Liquid trades above large-in-scale should be treated similarly to illiquid trades. When determining whether a particular product is liquid for the trading obligation, MiFIR recognizes that products may only be liquid up to a certain size. Similarly liquid trades above large-in-scale are treated similarly to illiquid trades in the pre-trade transparency regime as well (i.e. they are exempt). We would propose ESMA maintains this concept for post-trade transparency as well.
- There should not be a concept of end-of-day. As discussed previously, FX is a global 24 hour * 5.5 days/week market which does not have a concept of end-of-day. An arbitrary time (e.g. 15:00 CET) could lead to adverse market behavior if trades conducted at 14:59 CET are reported up to 12-24 hours sooner than trades conducted at 15:01 CET. We would propose, for illiquid trades (including liquid above LIS), that the deferral period be 48 hours after the trade occurred. That will ensure that the time a trade is conducted does not impact its reporting timeline, and, if sufficient masking is in place, allow enough time for liquidity providers to begin to risk manage their illiquid position.
- Under MiFIR Article 11(3) (b), ESMA has been delegated to determine what the extended period of deferral should be interpreted as. For illiquid trades (including liquid above large in scale), we would propose that the actual size not reported for an extended period

of deferral (e.g. 18 months). We believe that this proposal is in-line with the Level 1 text. The reasons for this are as follows:

- Consistency with global regulation: Given the cross-border function of FX in its role of underpinning the global payments system and the high volume and value of transactions occurring on a highly frequent basis, the GFXD's continued view is that any regulation should be harmonized at a global level where possible under the Level 1 requirements. Cross-border markets cannot operate in conflicting regulatory landscapes and the natural outcome, should this be the case, is unwanted fragmentation of what is an already highly automated, transparent FX market. As transparency obligations in Asia are going through their initial design phases and the US is already live with its transparency requirements, the GFXD recommends that the approach in Europe with respect to the publication of post trade data should at this stage be consistent, where possible, between the US and Europe.
- The implications of applying 2 different transparency obligations to the same trade could result in the trade data being made publically available in one region before the other and the contents inconsistent. This could lead to regulatory arbitrage and increased difficulty for market participants to hedge illiquid or large positions. For instance, if a European counterparty wanted to transact in a less liquid emerging market currency, of size (i.e. USD 1 billion v KZT) and their broker was a US Swap-Dealer, then once executed, it could transpire that the European Counterparty has to publish the full details of the trade (including volume) real-time, whilst the US swap-dealer would be able to cap their (deferred) real-time publication at USD 250 million. The real-world impact to publically reporting the full notional in Europe will create considerable difficulties in hedging or covering the full 1 billion USD v KZT notional in the market.
- It would be increasingly likely that the US Swap-Dealer would be less willing to enter into the transaction in the first place, and if they were to, then they would have to incur increased risk and considerable costs to either hold the position on their books until they could unwind in the market or hedge immediately, as the increased transparency would inform the market as to their position. Such an unintended consequence would therefore limit the ability in this instance for the European Counterparty to execute the transaction, and if that transaction was to fund a specific investment, then that investment could be at risk.
- On a macro-economic level these restrictions will have negative implications for business growth agendas either at a specific firm level or country level, specifically in those situations requiring FX activity.
- Information relating to mergers and acquisitions: The process and execution of funding a cross-border merger or acquisition and the impact of the market having sight of the large orders or trades that are executed to facilitate and hedge deals should be considered. Given that deals can take multiple months and sometimes years to conclude, are contingent on particular terms being met through the lifecycle, it is important that any information relating to deals is kept to a minimum to prevent any chance of 'front-running'. Size of FX orders or trades executed to hedge being published may lead to the market being able to infer the potential for, or near conclusion of, a merger or acquisition.



- TRACE Reporting: Similar deferrals of size publication are already in existence under the Financial Industry Regulatory Authority's (FINRA) Trade Reporting and Compliance Engine (TRACE) in the US, where the publication of the actual size for large in scale trades is deferred up to 18 months from trade date.

Table 14: Proposed Deferral Periods for FX

| Size of Transaction | Deferral Period (if Authorised by CA) | Details Published <u>During</u> Deferral Period | Details Published <u>After</u> Deferral Period if requested by the Competent Authority |
|---|---|--|--|
| Non-equity instruments assessed as having a liquid market | | | |
| Size below large-in-scale and size-specific thresholds | None | Publication of all details within 15 minutes | N/A |
| Size below large-in-scale but above size-specific thresholds | 60 minutes | All details to be published as close to real time as technically possible and no later than 15 minutes except volume, which can be omitted (indicated by a flag) for 60minutes | All details to be published after the deferral period is over |
| Liquid instruments above large-in-scale threshold * | 120 minutes With 18 months volume omission | All details to be published as close to real time as technically possible and no later than 15 minutes except volume, which can be omitted (indicated by a flag) for 18 months | All details except volume to be published after the deferral period is over Actual volume made public after 18 months |
| Non-equity instruments assessed as having an illiquid market | | | |
| All products without a liquid market | 48 hours With 18 months volume omission | All details to be published after 48 hours minutes except volume, which can be omitted (indicated by a flag) for 18 months | All details except volume to be published after the deferral period is over Actual size made public after 18 months |

Finally, we would also like to clarify that as the text implies that each NCA within Europe can apply a deferral in their own market, that we consider this to be ineffective when trying to implement consistent regulations across European jurisdictions, and again suggest that there has to be a consistent application of deferrals across Europe.

<ESMA_QUESTION_143>

Q144: Do you consider there are reasons for applying different deferral periods to different asset classes, e.g. fixing specific deferral periods for sovereign bonds? Please provide arguments to support your answer.

<ESMA_QUESTION_144>

AFME Response

FIXED INCOME

AFME partially agrees.

AFME believes that there should be a different regime for equities, fixed income and derivatives. However, there should not be different periods across the different asset classes for bonds/SFPs. To qualify, there should not be a different regime for sovereign bonds.

However, we do propose that there should be different deferral periods on the basis of issue size category (greater than EUR 5bn, between EUR 500m and 5bn and less than EUR 500mm). Please see our response to DP Question 112 for details on issue size categorisation.

FOREIGN EXCHANGE

For FX, the GFXD believes that differing deferrals could be applied for different asset classes. Each asset class has its own characteristics with respect to market conditions, liquidity profiles and trading patterns. Additionally, the GFXD would like to propose a modified version of ESMA’s proposal which is reflected in Table 15 below. The key changes we would like to suggest are:

- Liquid trades above large-in-scale should be treated similarly to illiquid trades. When determining whether a particular product is liquid for the trading obligation, MiFIR recognizes that products may only be liquid up to a certain size. Similarly liquid trades above large-in-scale are treated similarly to illiquid trades in the pre-trade transparency regime as well (i.e. they are exempt). We would propose ESMA maintains this concept for post-trade transparency as well.
- There should not be a concept of end-of-day. As discussed previously, FX is a global 24 hour * 5.5 days/week market which does not have a concept of end-of-day. An arbitrary time (e.g. 15:00 CET) could lead to adverse market behavior if trades conducted at 14:59 CET are reported up to 12-24 hours sooner than trades conducted at 15:01 CET. We would propose, for illiquid trades (including liquid above LIS), that the deferral period be 48 hours after the trade occurred. That will ensure that the time a trade is conducted does not impact its reporting timeline, and, if sufficient masking is in place, allow enough time for liquidity providers to begin to risk manage their illiquid position.
- Under MiFIR Article 11(3) (b), ESMA has been delegated to determine what the extended period of deferral should be interpreted as. For illiquid trades (including liquid above large in scale), we would propose that the actual size not reported for an extended period of deferral (e.g. 18 months). We believe that this proposal is in-line with the Level 1 text. The reasons for this are as follows:
 - Consistency with global regulation: Given the cross-border function of FX in its role of underpinning the global payments system and the high volume and value of transactions occurring on a highly frequent basis, the GFXD's continued view is that any regulation should be harmonized at a global level where possible under the Level 1 requirements. Cross-border markets cannot operate in conflicting regulatory landscapes and the natural outcome, should this be the case, is unwanted fragmentation of what is an already highly automated, transparent FX market. As transparency obligations in Asia are going through their initial design phases and the US is already live with its transparency requirements, the GFXD recommends that the approach in Europe with respect to the publication of post trade data should at this stage be consistent, where possible, between the US and Europe.
 - The implications of applying 2 different transparency obligations to the same trade could result in the trade data being made publically available in one region before the other and the contents inconsistent, This could lead to regulatory arbitrage and increased difficulty for market participants to hedge illiquid or large positions. For instance, if a European counterparty wanted to transact in a less liquid emerging market currency, of size (i.e. USD 1 billion v KZT) and their broker was a US Swap-Dealer, then once executed, it could transpire that the European Counterparty has to publish the full details of the trade (including volume) real-time, whilst the US swap-dealer would be able to cap their (deferred) real-time publication at USD 250 million. The real-world impact to publically reporting the full notional in Europe will create considerable difficulties in hedging or covering the full 1 billion USD v KZT notional in the market.
 - It would be increasingly likely that the US Swap-Dealer would be less willing to enter into the transaction in the first place, and if they were to, then they would have to incur increased risk and considerable costs to either hold the position on their books until they could unwind in the market or hedge immediately, as the increased transparency would inform the market as to their position. Such an

unintended consequence would therefore limit the ability in this instance for the European Counterparty to execute the transaction, and if that transaction was to fund a specific investment, then that investment could be at risk.

- On a macro-economic level these restrictions will have negative implications for business growth agendas either at a specific firm level or country level, specifically in those situations requiring FX activity.
- Information relating to mergers and acquisitions: The process and execution of funding a cross-border merger or acquisition and the impact of the market having sight of the large orders or trades that are executed to facilitate and hedge deals should be considered. Given that deals can take multiple months and sometimes years to conclude, are contingent on particular terms being met through the lifecycle, it is important that any information relating to deals is kept to a minimum to prevent any chance of ‘front-running’. Size of FX orders or trades executed to hedge being published may lead to the market being able to infer the potential for, or near conclusion of, a merger or acquisition.
- TRACE Reporting: Similar deferrals of size publication are already in existence under the Financial Industry Regulatory Authority’s (FINRA) Trade Reporting and Compliance Engine (TRACE) in the US, where the publication of the actual size for large in scale trades is deferred up to 18 months from trade date.

Table 15: Proposed Deferral Periods for FX

| Size of Transaction | Deferral Period (if Authorised by CA) | Details Published <u>During</u> Deferral Period | Details Published <u>After</u> Deferral Period if requested by the Competent Authority |
|---|---|--|--|
| Non-equity instruments assessed as having a liquid market | | | |
| Size below large-in-scale and size-specific thresholds | None | Publication of all details within 15 minutes | N/A |
| Size below large-in-scale but above size-specific thresholds | 60 minutes | All details to be published as close to real time as technically possible and no later than 15 minutes except volume, which can be omitted (indicated by a flag) for 60minutes | All details to be published after the deferral period is over |
| Liquid instruments above large-in-scale threshold * | 120 minutes With 18 months volume omission | All details to be published as close to real time as technically possible and no later than 15 minutes except volume, which can be omitted (indicated by a flag) for 18 months | All details except volume to be published after the deferral period is over Actual volume made public after 18 months |
| Non-equity instruments assessed as having an illiquid market | | | |
| All products without a liquid market | 48 hours With 18 months volume omission | All details to be published after 48 hours minutes except volume, which can be omitted (indicated by a flag) for 18 months | All details except volume to be published after the deferral period is over Actual size made public after 18 months |

Finally, we would also like to clarify that as the text implies that each NCA within Europe can apply a deferral in their own market, that we consider this to be ineffective when trying to implement consistent regulations across European jurisdictions, and again suggest that there has to be a consistent application of deferrals across Europe.

<ESMA_QUESTION_144>

Q145: Do you support the proposal that the deferral for non-equity instruments which do not have a liquid market should be until the end of day + 1? Please provide reasons for your answer.

<ESMA_QUESTION_145>

AFME Response

FIXED INCOME

No. AFME disagrees.

(i) T+1 delay

For the reasons set out above in answer to **DP Question 142**, a T+1 delay for illiquid instruments is not appropriate or sufficient to ensure that market makers will have sufficient time to hedge their risks and unwind their positions. The more illiquid an instrument, the more difficult it is for a market maker to hedge and unwind risk. Without a meaningful deferral, it will discourage market makers from participating in illiquid markets, which will introduce procyclical effects, and will make commitment of capital expensive. Therefore, we strongly recommend that illiquid instruments benefit from the maximum extended time delay of 6-12 months (that we recommend for LIS trades for liquid instruments).

We note that even with a 6-12 month deferral for volume, we note that there will be significant adverse impacts on illiquid markets if the price is published with a deferral of 48 hours. As illiquid markets have such little depth, other market participants will be able to immediately identify the market maker with the position and be able to take contrarian positions.

(ii) ESMA can optimise the levels of transparency by introducing real time post trade transparency for small trades for illiquid instruments (greater than EUR 500mm in issue size) rather than setting the liquidity threshold inappropriately low and minimising deferrals for large trades

Further, as set out in answer to **Question 141**, we do not agree with ESMA that the size specific threshold and large in scale threshold should only apply to liquid instruments. The conditions under MiFIR Article 11 are not stated to be mutually exclusive. As discussed in our response to **DP Question 112**, except for issue sizes below <500mm, we propose for there to be real-time reporting for below a size specific threshold for illiquid instruments to ensure optimum transparency that mitigates risks.

We note that ESMA has set low thresholds, we understand, as a means to optimise the level of transparency that the MiFID II regime will introduce. We believe that it is inappropriate for the levels to be set unduly low purely for the purpose of optimising transparency levels. If illiquid instruments are deemed liquid, they will be subject to the same pre and post trade transparency regimes as actual liquid instruments. As noted above, if an instrument does not trade every day, it cannot be liquid. We believe that there will be unintended consequences if the thresholds are set in this way, in that it will become too expensive for market makers to commit capital for facilitate trades in illiquid instruments – this will create procyclical effects (illiquid instruments will become more illiquid) and costs to investors/borrowing costs for issuers will increase.

Another means of optimising post trade transparency, is to look to where the concentration of trades are. We note that the ESMA scenarios capture a significant amount of trade volume but the proportion of transactions is significantly less (on average 22% less). The reason for this is that a significant proportion of trade flow is in illiquid instruments in small sizes. The majority of trade flow is not in larger size trades. For example, in government bonds, approximately 16% of trades take place in sizes of less than EUR 1mm in instruments that trade less than 9 times a day. Conversely, only trades in sizes greater than EUR 20mm in government bonds that trade more than 20 times per day only make up approximately 6% of trade flow. Further, for corporate bonds, approximately 60% of trade flow takes place in sizes of less than EUR 500k in bonds that trade less than three times per day but less than 0.01% of trade flow is generated from large trades of greater than EUR 10mm in instruments that trade approximately 10 times a day.

As such, we recommend that instead of inappropriately low thresholds for liquidity (that capture illiquid instruments), small trade sizes for instruments without a liquid market to be subject to

real time publication for the purposes for post trade transparency. As such, transparency will be optimised without compromising the non-liquid markets. For example, the ESMA scenarios achieve 35.26%-75.40% “liquid” transparency levels for all bonds; however, the AFME proposed liquidity levels, which includes small illiquid trades for EUR 500mm-5bn, achieves 72-78% of transactions subject to the “liquid” regime.

Instruments with EUR <=500mm issue sizes should be deemed illiquid outright, and, as such, should not be subject to the “liquid” regime.

AFME’s proposed transparency deferrals for illiquid instruments are:

For instruments with an issue size EUR >5bn & EUR 500mm-5bn

| Size of transaction | Deferral period | Details to be published after the deferral period |
|--|---|--|
| Size is below the threshold for size specific to the instrument and large in scale | N/A | Publication of all details as close to real time as is technically possible and no later than 15 minutes |
| Size is equal or above size specific to the instrument | Price: 48 hours Volume extended delay: 6-12 months | Price to be published after the delay with an indication that the volume is LIS Volume to be published after the extended delay |

For instruments <500mm

As discussed in answer to **DP Question 112**, small issue sizes equal to or less than EUR 500mm in issue size should be deemed illiquid and should receive the maximum deferral irrespective of the trade size.

| Size of transaction | Deferral period | Details to be published after the deferral period |
|----------------------|---|--|
| Illiquid instruments | Price: 48 hours Volume extended delay: 6-12 months | Price to be published after the delay with an indication that the volume is LIS Volume to be published after the extended delay |

FOREIGN EXCHANGE

For FX, the GFXD would like to propose a modified version of ESMA’s proposal which is reflected in Table 16 below. The key changes we would like to suggest are:

- Liquid trades above large-in-scale should be treated similarly to illiquid trades. When determining whether a particular product is liquid for the trading obligation, MiFIR recognizes that products may only be liquid up to a certain size. Similarly liquid trades above large-in-scale are treated similarly to illiquid trades in the pre-trade transparency

regime as well (i.e. they are exempt). We would propose ESMA maintains this concept for post-trade transparency as well.

- There should not be a concept of end-of-day. As discussed previously, FX is a global 24 hour * 5.5 days/week market which does not have a concept of end-of-day. An arbitrary time (e.g. 15:00 CET) could lead to adverse market behavior if trades conducted at 14:59 CET are reported up to 12-24 hours sooner than trades conducted at 15:01 CET. We would propose, for illiquid trades (including liquid above LIS), that the deferral period be 48 hours after the trade occurred. That will ensure that the time a trade is conducted does not impact its reporting timeline, and, if sufficient masking is in place, allow enough time for liquidity providers to begin to risk manage their illiquid position.
- Under MiFIR Article 11(3) (b), ESMA has been delegated to determine what the extended period of deferral should be interpreted as. For illiquid trades (including liquid above large in scale), we would propose that the actual size not reported for an extended period of deferral (e.g. 18 months). We believe that this proposal is in-line with the Level 1 text. The reasons for this are as follows:
 - Consistency with global regulation: Given the cross-border function of FX in its role of underpinning the global payments system and the high volume and value of transactions occurring on a highly frequent basis, the GFXD's continued view is that any regulation should be harmonized at a global level where possible under the Level 1 requirements. Cross-border markets cannot operate in conflicting regulatory landscapes and the natural outcome, should this be the case, is unwanted fragmentation of what is an already highly automated, transparent FX market. As transparency obligations in Asia are going through their initial design phases and the US is already live with its transparency requirements, the GFXD recommends that the approach in Europe with respect to the publication of post trade data should at this stage be consistent, where possible, between the US and Europe.
 - The implications of applying 2 different transparency obligations to the same trade could result in the trade data being made publically available in one region before the other and the contents inconsistent, This could lead to regulatory arbitrage and increased difficulty for market participants to hedge illiquid or large positions. For instance, if a European counterparty wanted to transact in a less liquid emerging market currency, of size (i.e. USD 1 billion v KZT) and their broker was a US Swap-Dealer, then once executed, it could transpire that the European Counterparty has to publish the full details of the trade (including volume) real-time, whilst the US swap-dealer would be able to cap their (deferred) real-time publication at USD 250 million. The real-world impact to publically reporting the full notional in Europe will create considerable difficulties in hedging or covering the full 1 billion USD v KZT notional in the market.
 - It would be increasingly likely that the US Swap-Dealer would be less willing to enter into the transaction in the first place, and if they were to, then they would have to incur increased risk and considerable costs to either hold the position on their books until they could unwind in the market or hedge immediately, as the increased transparency would inform the market as to their position. Such an unintended consequence would therefore limit the ability in this instance for the European Counterparty to execute the transaction, and if that transaction was to fund a specific investment, then that investment could be at risk.

- On a macro-economic level these restrictions will have negative implications for business growth agendas either at a specific firm level or country level, specifically in those situations requiring FX activity.
- Information relating to mergers and acquisitions: The process and execution of funding a cross-border merger or acquisition and the impact of the market having sight of the large orders or trades that are executed to facilitate and hedge deals should be considered. Given that deals can take multiple months and sometimes years to conclude, are contingent on particular terms being met through the lifecycle, it is important that any information relating to deals is kept to a minimum to prevent any chance of ‘front-running’. Size of FX orders or trades executed to hedge being published may lead to the market being able to infer the potential for, or near conclusion of, a merger or acquisition.
- TRACE Reporting: Similar deferrals of size publication are already in existence under the Financial Industry Regulatory Authority’s (FINRA) Trade Reporting and Compliance Engine (TRACE) in the US, where the publication of the actual size for large in scale trades is deferred up to 18 months from trade date.

Table 16: Proposed Deferral Periods for FX

| Size of Transaction | Deferral Period (if Authorised by CA) | Details Published <u>During</u> Deferral Period | Details Published <u>After</u> Deferral Period if requested by the Competent Authority |
|---|---|--|--|
| Non-equity instruments assessed as having a liquid market | | | |
| Size below large-in-scale and size-specific thresholds | None | Publication of all details within 15 minutes | N/A |
| Size below large-in-scale but above size-specific thresholds | 60 minutes | All details to be published as close to real time as technically possible and no later than 15 minutes except volume, which can be omitted (indicated by a flag) for 60minutes | All details to be published after the deferral period is over |
| Liquid instruments above large-in-scale threshold * | 120 minutes With 18 months volume omission | All details to be published as close to real time as technically possible and no later than 15 minutes except volume, which can be omitted (indicated by a flag) for 18 months | All details except volume to be published after the deferral period is over Actual volume made public after 18 months |
| Non-equity instruments assessed as having an illiquid market | | | |
| All products without a liquid market | 48 hours With 18 months volume omission | All details to be published after 48 hours minutes except volume, which can be omitted (indicated by a flag) for 18 months | All details except volume to be published after the deferral period is over Actual size made public after 18 months |

The GFXD would also like to clarify that as the text implies that each NCA within Europe can apply a deferral in their own market, that we consider this to be ineffective when trying to implement consistent regulations across European jurisdictions, and again suggest that there has to be a consistent application of deferrals across Europe. We would also like to suggest that any reporting requirements should be aligned between EMIR and MiFIR to prevent any unintended consequences of trade data or market positions being made available to the market.

<ESMA_QUESTION_145>

Q146: Do you think that one universal deferral period is appropriate for all non-equity instruments which do not have a liquid market or that the deferrals should be set at a more granular level, depending on asset class and even sub asset class. Please provide reasons for your answer.

<ESMA_QUESTION_146>

FIXED INCOME

Yes. AFME agrees (based on the deferrals ESMA has proposed for the price information) (however, this is contingent on how the framework develops)

FOREIGN EXCHANGE

For FX, the GFXD supports the view that there should be consistency across all FX sub-product groups i.e. those represented in Annex 3.6.1 on page 134 of the Discussion Paper.

With specific reference to Annex 3.6.1 on page 134 of the Discussion Paper, the GFXD would like to state that the reference to 'cash settled forwards' be replaced with physically (deliverable) settling FX forward transactions, because cash settled forwards are non-deliverable forward transactions. A non-deliverable forward is an FX financial instrument that involves two transacting parties executing an FX forward contract on the basis of non-delivery (i.e. cash, not physical, settlement) which involves the fixing (i.e. valuation) of the contract and therefore settlement in single reference currency. We also suggest that the 'FX Swap' product type should be broken down at the sub-product type to 'Deliverable Swaps' and 'Non-Deliverable Swaps'. Finally, we would like to state, with reference to the ESMA EMIR Q&A, TR Question 1, that cross-currency swaps are 'financial instruments should be classified as interest rates, in line with current market practice' rather than as FX instruments. Table 17 below shows a representative illustration of how Annex 3.6.1 could look for FX.

Table 17: Suggested Annex 3.6.1 for FX

<ESMA_QUESTION_146>

Q147: Do you agree with the proposal that during the deferred period for non-equity instruments which do not have a liquid market, the volume of the transaction should be omitted but all the other details of individual transactions must be published? Please provide reasons for your answer.

<ESMA_QUESTION_147>

AFME Response

FIXED INCOME

No. AFME does not agree.

For illiquid trades the information of the details of the trade should only be made available after a **deferral** (except as we propose for sizes smaller than SSTI for trades in instruments with issue sizes greater than EUR 500mm).

The more illiquid an instrument, the more difficult it is for a market maker to hedge and unwind risk. Without a meaningful deferral, it will discourage market makers from participating in

illiquid markets, which will introduce procyclical effects, and will make commitment of capital expensive.

For volume, the information should be available after an **extended deferral**. Therefore, we strongly recommend that illiquid instruments benefit from the maximum extended time delay of 6-12 months for volume (that we recommend for LIS trades for liquid instruments).

We note that even with a 6-12 month deferral for volume, we note that there will be significant adverse impacts on illiquid markets if the price is published with a deferral of 48 hours. As illiquid markets have such little depth, other market participants will be able to immediately identify the market maker with the position and be able to take contrarian positions.

FOREIGN EXCHANGE For FX, the GFXD would like to propose a modified version of ESMA's proposal which is reflected in Table 18 below. The key changes we would like to suggest are:

- Liquid trades above large-in-scale should be treated similarly to illiquid trades. When determining whether a particular product is liquid for the trading obligation, MiFIR recognizes that products may only be liquid up to a certain size. Similarly liquid trades above large-in-scale are treated similarly to illiquid trades in the pre-trade transparency regime as well (i.e. they are exempt). We would propose ESMA maintains this concept for post-trade transparency as well.
- There should not be a concept of end-of-day. As discussed previously, FX is a global 24 hour * 5.5 days/week market which does not have a concept of end-of-day. An arbitrary time (e.g. 15:00 CET) could lead to adverse market behavior if trades conducted at 14:59 CET are reported up to 12-24 hours sooner than trades conducted at 15:01 CET. We would propose, for illiquid trades (including liquid above LIS), that the deferral period be 48 hours after the trade occurred. That will ensure that the time a trade is conducted does not impact its reporting timeline, and, if sufficient masking is in place, allow enough time for liquidity providers to begin to risk manage their illiquid position.
- Under MiFIR Article 11(3) (b), ESMA has been delegated to determine what the extended period of deferral should be interpreted as. For illiquid trades (including liquid above large in scale), we would propose that the actual size not reported for an extended period of deferral (e.g. 18 months). We believe that this proposal is in-line with the Level 1 text. The reasons for this are as follows:
 - Consistency with global regulation: Given the cross-border function of FX in its role of underpinning the global payments system and the high volume and value of transactions occurring on a highly frequent basis, the GFXD's continued view is that any regulation should be harmonized at a global level where possible under the Level 1 requirements. Cross-border markets cannot operate in conflicting regulatory landscapes and the natural outcome, should this be the case, is unwanted fragmentation of what is an already highly automated, transparent FX market. As transparency obligations in Asia are going through their initial design phases and the US is already live with its transparency requirements, the GFXD recommends that the approach in Europe with respect to the publication of post trade data should at this stage be consistent, where possible, between the US and Europe.
 - The implications of applying 2 different transparency obligations to the same trade could result in the trade data being made publically available in one region before the other and the contents inconsistent, This could lead to regulatory

arbitrage and increased difficulty for market participants to hedge illiquid or large positions. For instance, if a European counterparty wanted to transact in a less liquid emerging market currency, of size (i.e. USD 1 billion v KZT) and their broker was a US Swap-Dealer, then once executed, it could transpire that the European Counterparty has to publish the full details of the trade (including volume) real-time, whilst the US swap-dealer would be able to cap their (deferred) real-time publication at USD 250 million. The real-world impact to publically reporting the full notional in Europe will create considerable difficulties in hedging or covering the full 1 billion USD v KZT notional in the market.

- It would be increasingly likely that the US Swap-Dealer would be less willing to enter into the transaction in the first place, and if they were to, then they would have to incur increased risk and considerable costs to either hold the position on their books until they could unwind in the market or hedge immediately, as the increased transparency would inform the market as to their position. Such an unintended consequence would therefore limit the ability in this instance for the European Counterparty to execute the transaction, and if that transaction was to fund a specific investment, then that investment could be at risk.
- On a macro-economic level these restrictions will have negative implications for business growth agendas either at a specific firm level or country level, specifically in those situations requiring FX activity.
- Information relating to mergers and acquisitions: The process and execution of funding a cross-border merger or acquisition and the impact of the market having sight of the large orders or trades that are executed to facilitate and hedge deals should be considered. Given that deals can take multiple months and sometimes years to conclude, are contingent on particular terms being met through the lifecycle, it is important that any information relating to deals is kept to a minimum to prevent any chance of 'front-running'. Size of FX orders or trades executed to hedge being published may lead to the market being able to infer the potential for, or near conclusion of, a merger or acquisition.
- TRACE Reporting: Similar deferrals of size publication are already in existence under the Financial Industry Regulatory Authority's (FINRA) Trade Reporting and Compliance Engine (TRACE) in the US, where the publication of the actual size for large in scale trades is deferred up to 18 months from trade date.

Table 18: Proposed Deferral Periods for FX



| Size of Transaction | Deferral Period (if Authorised by CA) | Details Published <u>During</u> Deferral Period | Details Published <u>After</u> Deferral Period if requested by the Competent Authority |
|---|---|--|--|
| Non-equity instruments assessed as having a liquid market | | | |
| Size below large-in-scale and size-specific thresholds | None | Publication of all details within 15 minutes | N/A |
| Size below large-in-scale but above size-specific thresholds | 60 minutes | All details to be published as close to real time as technically possible and no later than 15 minutes except volume, which can be omitted (indicated by a flag) for 60minutes | All details to be published after the deferral period is over |
| Liquid instruments above large-in-scale threshold * | 120 minutes With 18 months volume omission | All details to be published as close to real time as technically possible and no later than 15 minutes except volume, which can be omitted (indicated by a flag) for 18 months | All details except volume to be published after the deferral period is over Actual volume made public after 18 months |
| Non-equity instruments assessed as having an illiquid market | | | |
| All products without a liquid market | 48 hours With 18 months volume omission | All details to be published after 48 hours minutes except volume, which can be omitted (indicated by a flag) for 18 months | All details except volume to be published after the deferral period is over Actual size made public after 18 months |

Finally, we would also like to clarify that as the text implies that each NCA within Europe can apply a deferral in their own market, that we consider this to be ineffective when trying to implement consistent regulations across European jurisdictions, and again suggest that there has to be a consistent application of deferrals across Europe.

<ESMA_QUESTION_147>

Q148: Do you agree that publication in an aggregated form with respect to sovereign debt should be authorised for an indefinite period only in limited circumstances? Please give reasons for your answers. If you disagree, what alternative approaches would you propose?

<ESMA_QUESTION_148>

AFME Response

FIXED INCOME

No. AFME does not agree

ESMA has proposed that (i) publication in an aggregated form with respect to sovereign bonds should be authorised for an indefinite period only in limited circumstances; (ii) extended deferrals for sovereign debt should only be applied in limited circumstances; (iii) additional deferrals permitted for sovereign debt would not be available for sovereign debt issued by third countries; and (iv) when the conditions which necessitate such action have passed, the conditions for authorising an indefinite time period of deferral should also lapse and all the details of the transaction should be made public

We do not agree that publication should be authorised for an indefinite period only in limited circumstances. MiFIR Article 21(4) does not provide that the aggregation should only apply in limited circumstances. We stress that the aggregation and other deferrals have been introduced to ensure that liquidity providers are not exposed to excessive risks and are not discouraged from committing capital to facilitate client trades. We recommend that the aggregation should be based on the need to mitigate these risks. Therefore, we suggest that ESMA calibrate to these risks. We believe that aggregation is another tool that ESMA can use to optimise transparency but minimise unintended consequences.

In terms of extended deferrals, we do not believe that these apply exclusively to sovereign debt or that there should be a different regime for sovereign debt. MiFIR Article 21(4) provides that the deferral regime for sovereign debt and non-sovereign debt differs in the aggregation of trade information: (a) in the case of non-sovereign debt, NCAs may allow the publication of several

transactions in an aggregated form during an extended period of deferral; and (b) in the case of sovereign instruments NCAs may allow the publication of several transactions in an aggregated form for an indefinite period of time.

We believe that third country sovereign debt should receive the same beneficial treatment as EU-sovereign debt. We believe that an inconsistent approach will introduce a global unlevel playing field and will discourage cross-jurisdictional trading with an adverse impact on Europe. We believe that ESMA should introduce equivalence provisions into the implementing provisions.

Finally, we do not agree with ESMA's proposal that indefinite does not mean indefinite. We believe MiFIR Article 21(4) is clear and unambiguous that non-sovereign debt will only remain aggregated for an extended time period but sovereign debt trade data will remain aggregated on an indefinite basis where conditions are met based on the criteria set out in Article 11. We strongly suggest that if aggregation is applied to sovereign bonds, it should be applied on an indefinite basis

<ESMA_QUESTION_148>

Q149: In your view, which criteria and/or conditions would it be appropriate to specify as indicating there is a need to authorise extended/indefinite deferrals for sovereign debt??

<ESMA_QUESTION_149>

AFME Response

FIXED INCOME

Generally, AFME believes that if appropriate delays and extended delays are set for all bond and SFPs such that they mitigate risks for liquidity providers, it will not be necessary to set a preferential treatment for sovereign bonds.

We believe that other types of debt (e.g. corporate bonds, covered bonds, securitisations) are of equal importance to the funding of economic growth in Europe. We therefore are against the singling out of one specific asset class, and instead propose a single framework that calibrates transparency on the basis of the liquidity of the individual instrument that does not disproportionately favour one asset. We believe that the proposed AFME proposed framework delivers the appropriate calibration, while safeguarding the liquidity and stability of the market.

<ESMA_QUESTION_149>

Q150: In your view, could those transactions determined by other factors than the valuation of the instrument be authorised for deferred publication to the end of day? Please provide reasons for your answer.

<ESMA_QUESTION_150>

AFME Response

FIXED INCOME

AFME recommends that transactions determined by other factors than the valuation of the instrument should be excluded from the scope of publication. Under Article 21(5)(b), ESMA has been asked to determine the application of the post trade transparency requirements to *“transactions involving the use of those financial instruments for collateral, lending or other purposes where the exchange of financial instruments is determined by factors other than the current market valuation of the financial instrument.”* We recommend that, in line with ESMA’s recommendations for SFT transactions, other trades that are not price forming should also be out of scope. For example, technical trades (such as interaffiliate transactions undertaken for the purposes of risk management) should not be published. Publication of non-price forming trades would not provide informational value for the purposes of price discovery and would be distortive.

We should be grateful for clarification from ESMA that intragroup transactions undertaken for the purposes of transferring risk within corporate groups do not need to be trade reported – i.e. an investment firm transferring risk in this way to another group entity should not be considered to have concluded a transaction for the purposes of Article 20 and 21 MiFIR. This would be equivalent to the requirements of the CFTC’s Part 43 reporting rules. Such transactions facilitate the appropriate risk management within a financial group, and do not have any relevance to the price formation process.

We provide the following by way of an example: Group entity A (an investment firm) purchases some bonds from its client. Such bonds are then immediately sold, on a back-to-back (i.e. same price, same quantity) basis, to Group entity B because Group entity B is where the group’s risk in respect of the relevant product is housed. We consider that the trade between Group entity A and its client is the only trade which should be reported in this instance, on the basis that it is this trade which is important to the price formation process, rather than the second trade which is purely undertaken for the purposes of intragroup organisational purposes. Similarly, where Group entity A purchases such bonds through a trading venue, rather than directly from a client, and then enters into a back-to back risk transfer transaction in respect of such bonds with Group entity B, only one trade should be reported to the market. That trade should, per our discussion above, be reported by the relevant trading venue.

AFME also believes that reporting primary trades could prove misleading where you would end up with lots (often hundreds) of late booked trades (after pricing and syndicate allocations had been determined) either with spurious trade times (reflecting booking time which often runs into the night) or simply very late bookings (certainly not anywhere near 5 minutes of execution). In addition, these trades are not price determining, at this stage everyone is a price taker. The consolidated tape would show a significant distortion in the market and exaggerate liquidity from a calibration perspective (the bond could in practice be totally illiquid post trade date if locked up by the buy-side).

FOREIGN EXCHANGE

For FX, the GFXD recommends that only those transactions which are determined by the valuation of the instrument should be subject to the post-trade transparency obligations (which includes price forming post-trade events) and would therefore be consistent with the CFTC requirements under Part 43 of the Dodd-Frank Act. Transactions whose publication will not contribute to the price forming process, such as compressions, prime brokerage (traditional, reverse give-ups, 4 way and customer-to customer) and transactions entered into for dealer risk management purposes (i.e. internal operational reasons rather than client trades) should not be reported.



The GFXD also requests clarity on the trade reporting requirements for block v allocated trades and suggests that as with other recommendations, that any European approach is implemented in-line with the approaches used in other jurisdictions, such as the US.

<ESMA_QUESTION_150>

3.9. The transparency regime of non-equity large in scale orders and transactions

Q151: Do you agree with the proposed option? Which option would be more suitable for the calibration of the large in scale requirements within an asset class?

<ESMA_QUESTION_151>

AFME Response

FOREIGN EXCHANGE

For FX, the GFXD agrees with ESMA and supports Option 2 in the process to calibrate the large in scale thresholds. Specifically for FX, the GFXD believes that a more granular COFIA model is more relevant and recommends that the large in scale thresholds should be applied to the sub-product, currency pair and maturity of a transaction (e.g. a 3 month EUR/USD Vanilla Option).

FIXED INCOME

No. AFME does not agree with the proposed option.

(i) *Large in scale should not be computed at the level of asset classes or classes of financial instruments*

First, we disagree with ESMA's opinion that the post trade and pre trade large in scale should be computed at the level of asset classes or classes of financial instruments for the sake of consistency with the current regime for shares. The fixed income market is not the same as the equities market and the same regime should not be applied.

(ii) *Option 1 should apply – there should be a super-liquid and liquid category for issue sizes of EUR >=5bn (as long as the EUR 500mm-5bn framework is appropriately calibrated – only a liquid/illiquid category is necessary)*

We agree with option 1. As proposed in our response to **DP Question 112**, we suggest that bonds SFPs should be categorised by issue size and there should be two liquid categories: super-liquid and liquid. Such an approach would permit liquidity to be optimised according to the liquidity band of the instrument. It would also be able to capture the dynamic nature of liquidity – if the liquidity of an instrument changes or there is a change in market condition (e.g. market stress or boom), instruments would simply change liquidity category. For example, a bond is typically most liquid immediately after issuance and becomes less liquid over time – these changes would be captured in such a model.

We propose there is no need to have three liquidity categories; instruments with a low liquidity will be captured as illiquid. Further, we do not agree with the proposal to have different treatments for asset classes. We believe this is duplicative and does not add value. A categorisation

by issuance size is the most appropriate – as set out in AFME’s response to **DP Question 112**. We reiterate that a super-liquid category is not needed for the issue size category of 500mm-5bn if the liquid/illiquid threshold is set appropriately.

AFME proposal

| | The minimum size qualifying orders/transactions as large in scale compared with normal market size | |
|---------------|--|-------------------------------|
| | Super-liquid (higher liquidity band) | Liquid (lower liquidity band) |
| EUR >5bn | X1 | Y1 |
| EUR 500mm-5bn | n/a | Y2 |
| EUR <500mm | n/a | n/a |

(iii) Centralised calibration is essential

ESMA has set out that that the disadvantages to Option 1 is that its initial implementation and ongoing computations would be costly and time-demanding since it would require the development of a database similar to the current MiFID database for all non-equity financial instruments that are under the scope of the new MiFID regime.

We believe that the importance of developing an economically sound MiFID regime for fixed income outweighs the costs to develop supporting infrastructure by regulators and industry. ESMA has identified that the liquidity calibration should be based on frequency of trades and ADT, which are European-wide parameters. In-on-of-itself, such a calibration would need to be undertaken centrally – such a calibration cannot be undertaken at NCA or investment firm level. Further, given the liquidity-sensitive nature of fixed income instruments, we believe the maintenance of a single central list of instruments is more critical for fixed income and is unavoidable. Simply because the scale of the application of MiFID to fixed income is greater than for equities, does not justify infrastructure that is not fit for purpose. AFME strongly recommends that the regime is calibrated through a single central calibrating entity for maintaining all static and reference data as well as undertaking dynamic calibration that uses data from the entire European market. Having NCAs collecting the same data and undertaking the same calculations individually will result in an inconsistent, unworkable and highly fragmented regime. Such a fragmented regime is in direct contradiction of the objectives set out in MiFIR (Recital 2) to: “*In the context of the future European supervision architecture, the European Council of 18 and 19 June 2009 stressed the need to establish a European single rule book applicable to all financial instruments in the internal market*”. Given the inevitable operational need for a centralised calibration (based on the other proposals of ESMA for fixed income), we believe a more dynamic approach calibrated at instrument level would be operationally feasible (please see AFME’s responses to **DP Questions 132 and 178**).

(iv) Option 2 – a COFIA approach is not appropriate for bonds and SFPs

Further, ESMA sets out that the advantage of Option 2 is that it is simpler “*to implement on an ongoing basis insofar in it would not require periodic calculation on an instrument by instrument basis: once the threshold has been determined for each class, a transaction above such a size would be large in scale*”. AFME does not agree with this statement. As AFME has set out in response to Question 113, a COFIA approach is not workable or meaningful for bond and SFPs – as such, thresholds for large in scale based on COFIA. We also stress that a COFIA approach is not simpler operationally and requires more intensive centralised calibration.

(v) *In a package trade, all components should receive the benefit of a deferral is one component is above the large in scale threshold*

ESMA should give due consideration to the trade reporting requirements for instruments traded as part of a Package Transaction, as first mentioned in AFME’s response to Q103. By a Package Transaction we mean the following (1) the Package has two or more components that are priced as a package with simultaneous execution of all components and (2) the execution of each component is contingent on the execution of the other components. A package is designed to provide desired risk-return characteristics effectively in the form of a single transaction with efficiencies in execution cost and reduction in risk (market and operational) achieved through concurrent execution.

AFME’s recommendation is that where a component transaction of the package benefits from a deferral, the entire package should equally be able to benefit from the same period of deferral. Because the package is priced as a whole, the pricing of individual components may not be comparable to the pricing of comparable instruments in the market when traded on a stand-alone basis, and therefore we expect it to be of benefit to market participants for the whole package to be made public at the same time. This would also be consistent with our recommended treatment of packages for pre-trade transparency (not to subject a package to pre-trade transparency where at least one leg benefits from a waiver).

<ESMA_QUESTION_151>

Q152: Do you consider there are reasons for opting for different options for different asset classes? Please provide arguments.

<ESMA_QUESTION_152>

AFME Response

FIXED INCOME

Yes. AFME believes that there are reasons.

AFME believes that a different approach is appropriate for bonds and SFPs vs derivatives vs equities. However, for bonds, a more granular approach should not be adopted (i.e. there should not be a different approach for sovereign bonds and corporate bonds).

As set out in response to **DP Question 113**, an IBIA approach is essential for bonds and SFP. However, a COFIA approach may be appropriate for derivatives. As such, the options adopted will be dependent on whether adopts the IBIA and COFIA approach for the bonds, SFPs and derivatives.

However, as provided in our response to **DP Questions 112 and 151**, there does need to be issue size differentiation.

FOREIGN EXCHANGE

The GFXD considers that there may be suitable reasons for each asset class to opt for different options, but suggests that it would be best placed for each asset class to comment accordingly.<ESMA_QUESTION_152>

Q153: Do you agree that the choice between the two options should be consistent with the approach adopted for the assessment of liquidity? If not, please provide arguments.

<ESMA_QUESTION_153>

AFME Response

FIXED INCOME

Yes. AFME agrees.

FOREIGN EXCHANGE

The GFXD supports the opinion that the options for determining liquidity and large in scale should be consistent and for FX this is a more granular COFIA model and recommends that the large in scale thresholds should be applied to the sub-product, currency pair and maturity of a transaction (e.g. a 3 month EUR/USD Vanilla Option).

<ESMA_QUESTION_153>

Q154: Do you agree with the proposed approach? If no, which indicator would you consider more appropriate for the determination of large in scale thresholds for orders and transactions?

<ESMA_QUESTION_154>

AFME Response

FIXED INCOME

No. AFME does not agree with the proposed approach.

(i) *There does not need to be a consistent approach with large in scale and average trade size for liquidity calibration – ADT is not workable for large in scale*

First, AFME strongly disagrees with using ADT for calculating the threshold for large in scale. ESMA notes that it has a preference for Option 1 because it is consistent with the stated preference on average size in DP Section 3.6 as a proxy for average trade size. AFME recommends that there does not need to be a consistent approach for determining large in scale and average trade size for the purposes of liquidity because (i) MiFID/R does not provide that they are the same thresholds; and (ii) the purpose of the thresholds are different.

Specifically, MiFIR Article 2(a) provides that the definition of liquid market should consider the average size of transactions, whereas, MiFIR Article 11(1)(a) provides that NCAs may defer publication in respect of transactions that are large in scale compared with the normal market size for that bond. Further, “average trade size” under Article 2 is a condition for identifying whether or not an instrument has a liquid market. For this purpose, ADT is a good parameter because it determines the volume turnover of an instrument in a given time period, which is an important consideration in determining the liquidity of an instrument. For example, a bond may trade highly frequently; however, if total volume turnover is small, the instrument is not liquid. Large in scale, however, is a threshold used for the purposes of publication deferrals. Looking to the purpose of the deferrals, we understand that they are to ensure that liquidity providers are not

discouraged from committing capital to facilitate client trades by permitting market makers to have sufficient time hedge and unwind their risks.

With respect to the purpose of the deferral for large in scale compared to the normal trade size, ADT is not an appropriate proxy. ADT calculated by dividing the total volume turnover by the number of trading days. This measure does not approximate trade size that is large such that market makers would require a longer time period of deferral. For example, an instrument could have an ADT of 20mm but have an average daily frequency of 10 trades. However, depending on the liquidity of the instrument and the issue size, a trade significantly smaller in size could be large in scale such that it would need a longer period of deferral for hedging/unwinding of risk.

(ii) Neither ADT or AVT should be used as a proxy – ESMA should look to the purpose of the deferral and adopt a risk based approach

Second, AFME does not agree with using either ADT or AVT as a proxy for Large in Scale. We believe that threshold should be calculated on the basis of the purpose of the threshold – i.e. a risk based model. As such, we do not agree with either Option 1 or 2 – with regard to how Large in Scale should be calculated. A statistical measure of a central tendency is not correlated to the purpose of the threshold and the risks associated with the transparency provisions. A more policy orientated model is also not appropriate (i.e. minimum number of financial instruments/trading volume) because, again, it is not based on the purpose of the threshold or the risks associated with the regime. In times of market stress, the transparency regime should be sensitive to ensure that market makers are not discouraged from committing capital and in times of market boom, transparency is maximised. A target level of transparency is not sensitive to the dynamics and risks of the market.

(iii) AFME proposal for Large in Scale thresholds for post trade deferrals for bonds and SFPs

AFME proposes the thresholds for Large in Scale for the purposes of deferrals contained in the table below. We note that these thresholds only apply to the thresholds for superliquid and liquid that AFME has proposed in response to **DP Question 112**. Again, we note that we propose in instrument by instrument approach (IBIA) with issue size categories.

| | The minimum size qualifying orders/transactions as large in scale compared with normal market size | |
|-----------|--|-------------------------------|
| | Super-liquid (higher liquidity band) | Liquid (lower liquidity band) |
| EUR >5bn | EUR 20mm | EUR 10mm |
| 500mm-5bn | n/a | EUR 2.5mm |

These thresholds have been based on surveying dealers as to what is a large in scale transaction, whereby a longer time deferral would be needed for the purposes of hedging and unwinding risk. We recommend for ESMA to set the thresholds using a risk based approach – the thresholds can be reviewed by an specific ESMA taskforce set up for the purpose of reviewing the transparency thresholds. Therefore, for post trade deferrals, the Large in Scale threshold, as identified by ESMA in paragraph 22, should be based on giving the market maker sufficient time to hedge and unwind its risk position.



We note that the EUR 2.5 mm threshold is also approximately consistent with the block size for investment grade corporates under TRACE (we note that, as discussed in response to **DP Question 112**, the majority of corporate bonds fall within the EUR 500mm to 5bn issue size category) – where the threshold is USD 5mm.

We note that we have not proposed a Large in Scale threshold for bonds and SPFs with issue sizes less than EUR 500mm because we recommend that all instruments with small issue sizes should be treated as illiquid and, as such, the Large in Scale threshold need not apply.

FOREIGN EXCHANGE For FX, the GFXD considers that Option 2 would give a better representation of the average size of transactions, namely the total turnover over a period divided by the number of transactions in that period (i.e. the average turnover of transactions or AVT). Given that the FX market forms the basis of the global payments system, the market is typified as consisting of a high number of low notional transactions. We believe that Option 1 (total turnover divided by the number of trading days) would give an artificially high representation of what could constitute an average transaction size and if implemented could unintentionally include illiquid trades in any calculations as being liquid.<ESMA_QUESTION_154>

Q155: Do you agree that the proxy used for the determining the large in scale thresholds should be the same as the one used to assess the average size of transactions in the context of the definition of liquid markets? Please provide arguments.

<ESMA_QUESTION_155>

AFME Response

FIXED INCOME

No. AFME does not agree.

We recommend for ESMA to adopt a risk-based approach. Please see AFME's response to **DP Question 154**.

FOREIGN EXCHANGE

For FX, the GFXD agrees that the proxy used for the determining the large in scale thresholds should be the same as the one used to assess the average size of transactions in the context of the definition of liquid markets. Given that the FX market forms the basis of the global payments system, the market is typified as consisting of a high number of low notional transactions. We believe that the average daily turnover (total turnover divided by the number of trading days) would give an artificially high representation of what could constitute an average transaction size and if implemented could unintentionally classify illiquid trades as being liquid.

<ESMA_QUESTION_155>

Q156: In your view, which option would be more suitable for the determination of the large in scale thresholds? Please provide arguments.

<ESMA_QUESTION_156>

AFME Response



FIXED INCOME

AFME does not agree with either option.

We recommend for ESMA to adopt a risk-based approach. Please see AFME's proposal in **DP Question 154**.

FOREIGN EXCHANGE

For FX, the GFXD believes that Option 2, namely setting the large in scale thresholds on the basis of a more policy orientated method would be more appropriate. As mentioned in our responses to previous questions, the GFXD would support an approach where European and US regulatory transparency obligations are aligned as closely as possible, even if the CFTC approach results in a higher threshold than a statistical measure of central tendency. Whilst there may be future updates to both jurisdictional obligations, the US transparency regulations are currently live within the market, and any deviance for a cross-jurisdictional market like FX will result in an unwarranted bifurcation of the market for the reasons discussion in our response to question 141.

<ESMA_QUESTION_156>

Q157: Alternatively which method would you suggest for setting the large in scale thresholds?

<ESMA_QUESTION_157>

AFME Response

FIXED INCOME

AFME recommends for ESMA to adopt a risk-based approach and form an ongoing ESMA task-force to determine thresholds. Please see AFME's proposal to **DP Question 154**.

<ESMA_QUESTION_157>

Q158: In your view, should large in scale thresholds for orders differ from the large in scale thresholds for transactions? If yes, which thresholds should be higher: pre-trade or post-trade? Please provide reasons to support your answer.

<ESMA_QUESTION_158>

AFME Response

FIXED INCOME

No. AFME does not believe the large in scale waiver for post trade needs to differ from pre trade because pre trade waiver is only relevant non-RFQ and non-voice trading systems. However, as we note in response to **DP Question 163**, the risks for pre trade and post trade differ (please see below). As such, depending on the resulting post trade framework, the pre trade large in scale threshold may need to differ. Please also see AFME's response to **DP Question 154**.

(i) *Pre trade risks differ from post trade risks*

The risk associated with the post trade threshold is the time permitted for the market maker to unwind and hedge risk. The pre trade risks to the market maker is much greater than the post trade risks because the price formation process can be intervened with:

- other dealers could price against the market maker with regards and result in a race to the bottom in pricing that does not reflect market risk. Further, the disclosure of prices pre trade could result in predatory pricing practices; and
- other dealers could take contrarian positions against the market maker prior to execution, increasing the cost of hedging or unwinding of the market maker's risk.

Requests for quotes on and off venues are privately negotiated. In venues, it is typical for a real money client to request a quote from multiple dealers. The responses that are returned to the client are private (bilaterally); in other words, dealers party that are to the request for quote will not see each other's quotes. This allows market makers to protect their risk by ensuring that no-one can move the market against the potentially winning quote. Once the client has secured the best price within the live RFQ system and the trade is subsequently accepted by the dealer, that winning dealer is privy to immediate cover information, i.e. the differential between the accepted price and the next best price. The other dealers will know, after a rules-determined time period, if they covered, tied or if they traded away (typically meaning they provided the 3rd or less best price). Again the post trade information that is disseminated is deliberately designed to ensure that winner's curse is reduced as much as possible and is only available to those dealers that participated in the auction.

(ii) *Treatment of package trades – all components should benefit from the waiver when one component meets the LIS threshold*

ESMA should give due consideration to the Pre-Trade Transparency requirements for instruments traded as part of a Package Transaction, as we defined them in response to **DP Question 112**. AFME's recommendation is that where one or more component transactions of the package benefits from a waiver, the entire package should equally be able to benefit from the same waiver.

Simultaneous execution of a package with a single counterparty using a single execution method alleviates the timing and mechanical risks and lowers bid/offer costs to those of the intended risk of the package. Exposing one component transaction to pre-trade transparency requirements will jeopardise the ability of market participants to execute the entire package (primarily because exposure of an order in one transaction gives rise to the possibility of another party unrelated to the intended package trading that component transaction). Inability to execute packages will result in significantly increased costs and risks to market participants. These costs and risks arise primarily from three sources: (1) separately trading the components of a Package Transaction incurs the possibility of the market moving between executions of each component because such executions cannot be precisely time-matched, (2) there are likely to be differences in contract specifications, mode of execution, clearing/settlement workflows and relative liquidity when components of a Packaged Transaction are executed separately and/or on different venues, and (3) accessing different sources of liquidity for the various components when traded across different venues or over-the-counter incurs additional bid/offer spreads.

Therefore it is imperative that the entire transaction benefit from a waiver from Pre-Trade Transparency in order that the entire package can be agreed between participants away from a venue. This would also be consistent with our recommended treatment of packages for Post-Trade Transparency (to allow the entire package to benefit from deferrals to Post-Trade Transparency where at least one leg benefits from a waiver).

FOREIGN EXCHANGE

For FX, the GFXD believes that the large in scale thresholds for post trade obligations should be higher than the large in scale thresholds for pre trade obligations, primarily due to the ability to

implement waivers for pre trade obligations versus a deferral for post trade transparency obligations. It is of critical importance to the wellbeing of the market that the positions of liquidity providers are not publically exposed, nor that their positions be calculated or implied. The exposure of a liquidity providers position to the market will have the following impacts: i) the provider may be unable to effectively hedge their position; ii) the costs of executing will be increased and these costs will be reflected in wider spreads to the client; iii) the provider may decide to stop offering quotes in certain instrument should they be unable to effectively manage their subsequent position

<ESMA_QUESTION_158>

Q159: Do you agree that the large in scale thresholds should be computed only on the basis of transactions carried out on trading venues following the implementation of MiFID II? Please, provide reasons for the answer.

<ESMA_QUESTION_159>

AFME Response

FIXED INCOME

Yes. AFME agrees for the reasons ESMA has set out

FOREIGN EXCHANGE

For FX, the GFXD supports the view that market data should be gathered from the trading venues following the implementation of MiFID II.

<ESMA_QUESTION_159>

Q160: Do you think that the condition for deferred publication of large in scale transactions currently applying to shares (transaction is between an investment firm that deals on own account and a client of the investment firm) is applicable to non-equity instruments? Please provide reasons for your answer.

<ESMA_QUESTION_160>

AFME Response

FIXED INCOME

AFME recommends that an investment firm should benefit from the deferred publication regime whenever it assumes risk in a transaction.

FOREIGN EXCHANGE

For FX, the GFXD does not support this approach and understands that an investment firm should benefit from the deferred publication regime whenever it assumes risk in a transaction. The FX market trades on a principal v principal basis. If transactions executed on a principal v principal basis are not included, the implications as discussed previously will apply, such as the unwillingness of market makers to enter into large transactions or their inability to accurately hedge positions.

<ESMA_QUESTION_160>

Q161: Do you agree that the large in scale regime should be reviewed no earlier than two years after application of MiFIR in practice?

<ESMA_QUESTION_161>

AFME Response

FIXED INCOME Yes. AFME agrees.

FOREIGN EXCHANGE

The GFXD suggests that ESMA adopt a similar approach to that observed by the CFTC in the US upon the publication of trade data in accordance with the CFTCs rule part 43. All transactions should be considered large in scale, until such a period that ESMA is able to sufficiently gather enough data from the trade repositories to enable the completion of a study to accurately set both the large in scale and the size specific to the instrument thresholds. We agree that this period, as consistently supported for all data gathering exercises should be no shorter than 2 years.

<ESMA_QUESTION_161>

3.10. Size specific to the instrument

Q162: Do you agree with the above description of the applicability of the size specific to the instrument? If not please provide reasons for your answer.

<ESMA_QUESTION_162>

AFME Response

FIXED INCOME

Yes. AFME agrees with the ESMA's description of the applicability of the size specific to the instrument for the reasons ESMA gives.

FOREIGN EXCHANGE

For FX, the GFXD agrees with ESMA's description of the applicability of the size specific to the instrument.

<ESMA_QUESTION_162>

Q163: Do you agree with the proposal that the size specific to the instrument should be set as a percentage of the large in scale size? Please provide reasons for your answer.

<ESMA_QUESTION_163>

AFME Response

No. AFME does not agree.

(i) *Size specific to the instrument should be determined using a risk-based approach*

We agree with ESMA that the methodology to calculate size specific to the instrument should have regard to not exposing liquidity providers to undue risk, with a view regarding whether liquidity providers would be able to hedge their risk. However, we stress that (as discussed in answer to **DP Question 142**), many bonds cannot be hedged easily (and as such the position needs to be unwound before the market maker has offloaded his risk). Therefore, undue risk of liquidity providers means that the market maker is unable to hedge risk or unwind his position (within a given timeframe).

There are further risks for pre trade. Under MiFID II, there are two types of pre trade risk (to which the SSTI threshold relates): (i) disclosure of pre trade quotes; and (ii) makings quotes available as an SI to multiple clients on a firm basis.

The post trade threshold is the time permitted for the market maker to unwind and hedge risk. The **disclosure** pre trade risks to the market maker are much greater than the post trade risks because the price formation process can be intervened with:

- other dealers could price against the market maker with regards and result in a race to the bottom in pricing that does not reflect market risk. Further, the disclosure of prices pre trade could result in predatory pricing practices; and
- other dealers could take contrarian positions against the market maker prior to execution, increasing the cost of hedging or unwinding of the market maker's risk.

Requests for quotes on and off venues are privately negotiated. In venues, it is typical for a real money client to request a quote from multiple dealers. The responses that are returned to the client are private (bilaterally); in other words, dealers party that are to the request for quote will not see each other's quotes. This allows market makers to protect their risk by ensuring that no-one can move the market against the potentially winning quote. Once the client has secured the best price within the live RFQ system and the trade is subsequently accepted by the dealer, that winning dealer is privy to immediate cover information, i.e. the differential between the accepted price and the next best price. The other dealers will know, after a rules-determined time period, if they covered, tied or if they traded away (typically meaning they provided the 3rd or less best price). Again the post trade information that is disseminated is deliberately designed to ensure that winner's curse is reduced as much as possible and is only available to those dealers that participated in the auction.

With regard to the size specific to the instrument threshold under the SI pre trade regime, whereby quotes have to be made available to other clients, there are additional risks. This requirement for SIs means that market makers would face inventory risks. Specifically, when a market maker agrees to provide a quote to a client, it is subject to the risk of all its clients trading on the price. Therefore, whilst under the current regime, a market maker would only have to price in the risk of one trade, a market maker under MiFID II needs to price in the risk of multiple trades (and the risks associated with hedging and unwinding). As such, as the size of the trade increases, the risk increases in magnitude.

We do not agree with ESMA (under paragraph 11), that size specific to the instrument should be linked to the concept of SMS in the equities regime. MiFID/R is clear that the purpose of size specific to the instrument is to introduce a threshold that is calibrated to the risks of liquidity providers. This is a completely different concept to standard market size – which is a threshold to determine the standard tick size. Further, the equities market is very different from the fixed income market, in that it is not dependent on market makers committing capital to facilitate trades.

Unlike a single class of shares, each fixed income security is dissimilar in terms of maturity, coupon, interest rate, liquidity, and rating. This creates imbalances in the number of buy and

sells orders placed by investors for a bond at any one time, especially in the current time of market stress. In this context, dealers’ own account trading has a crucial role in ensuring continuous markets and allowing client’s orders to be matched gradually over time. If market makers are discouraged from committing capital, clients’ flows would be unmatched. Such unmatched flows cause two problems: one is that the bond’s price may change abruptly, even if there has been no shift in either supply or demand for the bond. Second is that either buyers have to pay more, or sellers have to accept lower prices, if they want to make their trade immediately. It is therefore crucial that the new transparency regime is appropriately calibrated in order to protect liquidity in the market place.

Therefore, the size specific to the instrument threshold should be calibrated to the features and risks of the fixed income market and not the equities market.

Further, AFME understands that the outcome of Level 1 discussions during the Irish and Lithuanian Presidencies showed no intention for the size specific to the instrument threshold to be linked to “normal” size (or standard size). Stakeholders drew attention to the view that the concept of “normal market size” for non-equity instruments is fundamentally flawed as the EU markets for non-equities are very heterogeneous and predominantly professional, characterised by large value transactions by a small number of participants. Therefore, calculating an average “normal” size would mean that only extremely large non-equity transactions will be able to benefit from deferral/omission and this will result in non-equity liquidity providers most often having no time to hedge their risk.

(ii) AFME proposal

AFME proposes for ESMA to take a risk-based approach to calculating the threshold. Specifically, we propose the following thresholds are appropriate for bonds and SFPs. The thresholds have been based on surveying market participants as to what thresholds would cause undue risk and checking these thresholds against the number of transactions and volumes that would fall above/below the thresholds (with the aim of achieving optimal transparency).

i. For post trade transparency

| Issue size category | Size specific to the instrument |
|--|---------------------------------|
| Issue size EUR >5bn (liquid and illiquid instruments) | EUR 1mm |
| Issue size EUR 500mm-5bn (liquid and illiquid instruments) | EUR 500,000 |

We note that ESMA has set low liquidity thresholds, we understand, as a means to optimise the level of transparency that the MiFID II regime will introduce. We believe that it is inappropriate for the levels to be set unduly low purely for the purpose of optimising transparency levels. If illiquid instruments are deemed liquid, they will be subject to the same pre and post trade transparency regimes as actual liquid instruments. As noted above, if an instrument does not trade every day, it cannot be liquid. We believe that there will be unintended consequences if the thresholds are set in this way, in that it will become too expensive for market makers to commit capital for facilitate trades in illiquid instruments – this will create procyclical effects (illiquid instruments will become more illiquid) and costs to investors/borrowing costs for issuers will increase.

Another means of optimising post trade transparency, is to look to where the concentration of trades are. We note that the ESMA scenarios capture a significant amount of trade volume but the proportion of transactions is significantly less (on average 22% less). The reason for this is

that a significant proportion of trade flow is in illiquid instruments in small sizes. The majority of trade flow is not in larger size trades. For example, in government bonds, approximately 16% of trades take place in sizes of less than EUR 1mm in instruments that trade less than 9 times a day. Conversely, only trades in sizes greater than EUR 20mm in government bonds that trade more than 20 times per day only make up approximately 6% of trade flow. Further, for corporate bonds, approximately 51% of trade flow takes place in sizes of less than EUR 500k in bonds that trade less than three times per day but less than 0.01% of trade flow is generated from large trades of greater than EUR 10mm in instruments that trade approximately 10 times a day.

As such, we recommend that instead of inappropriately low thresholds for liquidity (that capture illiquid instruments), small trade sizes for instruments without a liquid market to be subject to real time publication for the purposes for post trade transparency. As such, transparency will be optimised without compromising the non-liquid markets. For example, the ESMA scenarios achieve 35.26%-75.40% “liquid” transparency levels for all bonds; however, the AFME proposed liquidity levels, which includes small illiquid trades for EUR 500mm-5bn, achieves 74.7% of transactions subject to the “liquid” regime.

As such, we recommend that the liquidity thresholds are set higher and for small trade sizes for instruments without a liquid market to not benefit from time delays for post trade transparency and for the size specific to the instrument threshold to apply to illiquid instruments for post trade transparency. This principle should not apply to pre trade transparency.

Analysing the TRAX data, our proposed thresholds provide the following levels of transparency:

Transparency for corporate bond sample set with issue sizes >EUR 500mm and EUR <5bn

| Real time price and volume | Percentage of all transactions | Percentage of all volume |
|---|---------------------------------------|---------------------------------|
| Real time price and volume | 75.0% | 9.49% |
| 60 minutes price and volume | 0.80% | 2.02% |
| 120 minutes price | 7.99% | 6.04% |
| 48 hours price | 2.21% | 82.4% |
| 6-12 months volume | 3.02% | 88.5% |
| Trades <SSTI (liquid and illiquid) Set at 500k | 75.0% | 9.49% |
| Trades >SSTI and <LIS (liquid) | 0.80% | 2.02% |
| Trades >LIS (liquid) | 7.99% | 6.04% |
| Trades >SSTI (illiquid) | 2.21% | 82.4% |



Source: TRAX¹⁶

ii. For pre trade transparency

If a risk-based approach is applied, the thresholds for the SSTI for pre trade should differ from the post trade threshold.

As ESMA has identified in the Discussion Paper, the SSTI waiver for pre trade transparency is only relevant for trading that has not been undertaken through request-for-quote or voice trading systems. On this basis and on the basis of the risks associated with pre trade transparency described above, we propose a threshold of EUR 150,000

| Issue size category | Size specific to the instrument |
|---------------------|---------------------------------|
| All | EUR 150,000 |

We believe that a EUR 150,000 threshold is appropriate for pre trade because:

- There are more risks relating to pre trade compared to post trade, which results in a need for a lower threshold;
- MiFIR Article 9(b) provides that the threshold should take into account whether the relevant market participants are retail or wholesale investors – pre trade transparency poses a greater risk to the wholesale market than the retail market – therefore, the threshold should ensure the retail market is captured by the requirements but the scope of the wholesale market should be limited;
- During the co-legislative process, the European Parliament identified EUR 100,000 as the threshold for pre trade transparency;
- The median trade size for corporate bonds is EUR 150,000; and
- Minimum quoting obligations exist on certain venues for trades below a certain size, which are good working examples of pre trade regimes in Europe. The size of those thresholds is below EUR 150,000. For example, EURO TLX has a liquidity provider quoting obligation on its venue. The standard size thresholds for those obligations are: EUR 100,000 for government bonds, EUR 50,000 for non-government bonds and EUR 25,000 for SFPs.
- Trades of EUR 150,000 or less make up approximately 97% of volume and 48% of transactions liquid corporate bonds of issue sizes greater than EUR 500mm and less than EUR 5bn based on AFME’s proposed liquidity thresholds in response to **DP Question 112** (using the TRAX data).

¹⁶ AFME has undertaken testing on trade data provided by TRAX. 10,091 traded fixed income bonds were randomly chosen from six asset classes (government bonds, supranationals, corporate bonds, high yield, covered bonds and securitisation). Trade data for these securities was tested over the period 1 October 2011 to 30 September 2013. Given that these securities were chosen at random, we can assume that this universe is proportionally representative.

FOREIGN EXCHANGE

For FX, the GFXD believes that a size specific threshold at lower size (e.g. EUR 10,000.00) would ensure that systematic internalisers are better able to honor further requests to trade at that quote, given it will have a lower chance of breaching that systematic internalisers commercial and risk limits and therefore agrees with ESMA's proposal that the size specific to the instrument should be set as a percentage of the large in scale size. We believe that this offers the most efficient (cost and implementation) method of setting the threshold. Given the significant transparency that already exists in the FX markets today we believe the intent of the size specific threshold should be to provide investors with access to quotes that have the highest chance of resulting in a trade, especially given the reference to retail investors in MiFIR Article 9 (5) (d):

the size specific to the financial instrument referred to in paragraph 1(b) and the definition of request-for-quote and voice trading systems for which pre-trade disclosure may be waived under paragraph 1;

When determining the size specific to the financial instrument that would expose liquidity providers to undue risk and takes into account whether the relevant market participants are retail or wholesale investors, in accordance with paragraph 1(b), ESMA shall take the following factors into account:

- (i) whether, at such sizes, liquidity providers would be able to hedge their risks;*
- (ii) where a market in the financial instrument, or a class of financial instruments, consists in part of retail investors, the average value of transactions undertaken by those investors;*
- (e) the financial instruments or the classes of financial instruments for which there is not a liquid market where pre-trade disclosure may be waived under paragraph 1.*

<ESMA_QUESTION_163>

Q164: In your view, what methodologies would be most appropriate for measuring the undue risk in order to set the size specific threshold?

<ESMA_QUESTION_164>

AFME Response

FIXED INCOME

AFME recommends for ESMA to adopt a risk based approach by forming a taskforce that identifies the appropriate thresholds on an ongoing basis.

FOREIGN EXCHANGE

For FX, the GFXD believes that each market maker will manage (via their own risk and commercial policies) the risk they are willing to take from each client segment and each particular type of FX instrument.

The GFXD believes it is more appropriate to establish the intention behind the size specific threshold and to use that on an asset/financial instrument specific basis to help set suitable thresholds rather than trying to calibrate a very subjective and dynamic parameter such as 'undue risk'. Given the significant transparency that already exists in the FX markets today we



believe the intent of the size specific threshold should be to provide investors with access to quotes that have the highest chance of resulting in a trade, especially given the reference to retail investors in MiFIR Article 9 (5) (d). A size specific threshold at lower size (e.g. EUR 10,000.00) would ensure that SIs are better able to honor further requests to trade at that quote, given it will have a lower chance of breaching that SI's commercial and risk limits.

<ESMA_QUESTION_164>

Q165: Would you suggest any other practical ways in which ESMA could take into account whether, at such sizes, liquidity providers would be able to hedge their risks?

<ESMA_QUESTION_165>

AFME Response

FIXED INCOME

Yes .We refer to AFME's proposals in Question 163.

FOREIGN EXCHANGE

The GFXD believes that each firm will manage their own market risks accordingly and that this will depend on the location and activity of each investment firm. For instance a firm located in a specific emerging market (EM) country is more likely to be able to offset any market risks in that EM currency compared to a counterparty that is long the same risk but resides in a country whose market is open at different times to the EM country. For this reason the GFXD does not believe that a standard approach should be applied to all market participants.

<ESMA_QUESTION_165>

Q166: Do you agree with ESMA's description of how the size specific to the instrument waiver would interact with the large in scale waiver? Please provide reasons for your answer.

<ESMA_QUESTION_166>

AFME Response

FIXED INCOME

No. AFME does not agree.

Please see AFME's proposals in Question 163 with regards to the thresholding of SSTI.

Further, the Large in Scale waiver should also apply to RFQ and voice trading systems in addition to the SSTI waiver. Under paragraph 13, ESMA has stated that the large in scale waiver will not be necessary where a SSTI waiver has been granted. For clarification, we stress that the large in scale pre trade waiver does provide an additional benefit for RFQ and voice trading systems (under MiFIR Article 9(1)). If an RFQ/voice trading system benefits from an SSTI waiver, the venue will still be required to make public at least indicative pre trade bid and offer prices which are close to trading interests (under MiFIR Article 8(4)). No such requirement is applicable to the large in scale waiver.

<ESMA_QUESTION_166>



Q167: Do you agree with ESMA’s description of how the size specific to the instrument deferrals would interact with the large in scale deferrals? In particular, do you agree that the deferral periods for the size specific to the instrument and the large in scale should differ and have any specific proposals on how the deferral periods should be calibrated? Please provide reasons for your answer.

<ESMA_QUESTION_167>

AFME Response

FIXED INCOME

No. AFME does not agree. Please see AFME’s response to Question 163.

FOREIGN EXCHANGE

For FX, the GFXD agrees with ESMA’s description of how the size specific to the instrument deferrals would interact with the large in scale deferrals. We believe that the larger the trade (implication being the liquidity is reduced as notional increases) the longer the deferral period should be, and that given the global nature of the FX markets and as mentioned in our response to question 141 we would support an approach where European and US regulatory transparency obligations are aligned as much as possible under MiFIR. This would mean that any deferrals in Europe could be more/less than those currently referenced.

<ESMA_QUESTION_167>

3.11. The Trading Obligation for Derivatives

Q168: Do you agree that there should be consistent categories of derivatives contracts throughout MiFIR/EMIR?

<ESMA_QUESTION_168>

AFME Response

FOREIGN EXCHANGE

For FX, the FX table included within Annex 3.6.1 (Financial instruments taxonomy and metrics for the calculation of the liquidity criteria (average size of transaction) on page 134 of the Discussion Paper references similar taxonomy to that which is included within the ISDA product taxonomy (http://www2.isda.org/attachment/NTQzOQ--/ISDA_OTC_Derivatives_Taxonomies_o_version2012-10-22.xls) and should be used by trading venues and market participants alike to harmonize classification across the FX asset class.

As described previously, the GFXD believes that the FX asset class should be categorized to the sub-product, currency pair level and maturity (e.g. a 3 month EUR/USD Vanilla Option).

With specific reference to Annex 3.6.1 on page 134 of the Discussion Paper, the GFXD would like to state that the reference to ‘cash settled forwards’ be replaced with physically (deliverable) settling FX forward transactions, because cash settled forwards are non-deliverable forward transactions. A non-deliverable forward is an FX financial instrument that involves two transacting parties executing an FX forward contract on the basis of non-delivery (i.e. cash, not physical, settlement) which involves the fixing (i.e. valuation) of the contract and therefore settlement in single reference currency. We also suggest that the ‘FX Swap’ product type should be broken down at the sub-product type to ‘Deliverable Swaps’ and ‘Non-Deliverable Swaps’. Finally, we



would like to state, with reference to the ESMA EMIR Q&A, TR Question 1, that cross-currency swaps are ‘financial instruments should be classified as interest rates, in line with current market practice’ rather than as FX instruments. Table 19 below shows a representative illustration of how Annex 3.6.1 could look for FX.

Table 19: Suggested Annex 3.6.1 for FX

| Financial Instrument | Product Types | Sub-Product Types | Recommended Liquidity sub-categories |
|------------------------------|---------------|--|--------------------------------------|
| Foreign Exchange Derivatives | Futures | N/A | Currency Pair Maturity |
| | Options | Non-Deliverable Option - NDO (only European type options are NDO - not any other FX options settled in non-deliverable currency) | |
| | | Vanilla Option (European and American) | |
| | Forwards | Deliverable Forward | |
| | | NDF | |
| | FX Swaps | Deliverable FX Swap | |
| | | Non-Deliverable FX Swap | |
| | Others | Simple exotic (Barrier & Digital) | |
| | | Complex Exotic | |



<ESMA_QUESTION_168>

Q169: Do you agree with this approach to the treatment of third countries?

<ESMA_QUESTION_169>

AFME Response

FOREIGN EXCHANGE

For FX, the GFXD agrees with the proposed approach to third countries.

<ESMA_QUESTION_169>

Q170: Do you agree with the proposed criteria based anti-avoidance procedure?

<ESMA_QUESTION_170>

AFME Response

FOREIGN EXCHANGE

For FX, the GFXD agrees with the proposed criteria based anti-avoidance procedure and that alignment to EMIR is of key consideration.

<ESMA_QUESTION_170>

Q171: Do you think it would be reasonable for ESMA to consult venues with regard to which classes of derivatives contracts are traded on venue? Do you think venues would be well placed to undertake this task?

<ESMA_QUESTION_171>

AFME Response

FOREIGN EXCHANGE

For FX, the GFXD recommends that as per Article 32 of MiFIR, ‘Trading obligation procedure’ that ESMA should conduct as part of its assessment into the trading obligation a public consultation at which stage we would expect the market to comment on which products are traded on venues. Given that there is a commercial element to a venue stating that it is able to trade a financial instrument, we would expect any assessment of this to be performed in a non-commercial manner, independently to the venues with final approval being made the relevant NCA or ESMA, as per our response to question 101.

The GFXD also requests clarity on the requirement in Article 18.1 of MiFIR ‘Obligation for systematic internalisers to make public firm quotes in respect of bonds, structured finance products, emission allowances and derivatives’ where it is required that investment firms shall make public firm quotes in respect of bonds, structured finance products, emission allowances and derivatives traded on a trading venue..’. Whilst the GFXD expects ESMA to publish a list of those financial instruments that are subject to a trading obligation, the GFXD requests that a similar list is maintained for those products that are offered by trading venues but are not subject to a trading obligation. As referenced in the Bank of England Semi-Annual FX Survey for October 2013, (<http://www.bankofengland.co.uk/markets/Pages/forex/fxjsc/default.aspx>), of the \$2.58 trillion executed per day in London just over half of this was conducted on a bi-lateral basis:

- \$1.31 trillion bi-lateral trading through interdealer direct, customer direct, single electronic trading systems

- \$1.27 trillion multi-lateral trading through electronic broking systems, multi electronic trading systems, voice broker

When this notional data is combined with the current challenges faced by the FX markets in clearing physically settling FX products, it could be concluded that at the inception of MiFIR, there will still be a considerable percentage of the FX market that remains either traded multi-laterally and is not subject to a trading obligation, or is traded bi-laterally. It could also be concluded that there could be a considerable over-lap in the types of financial instruments that are traded via both methods. It will therefore be increasingly difficult for each SI to consult each multi-lateral trading venue each time it executes a trade as a SI in order to validate whether that financial instrument had previously been traded on a multi-lateral venue and to then determine which transparency obligations apply to that trade. This process would be more efficient (both commercially and operationally) and would result in more transparency to the market if a SI could consult a single list that has been published by ESMA containing all financial instruments that can be traded on a trading venue.

<ESMA_QUESTION_171>

Q172: The discussion in section 3.6 on the liquid market for non-equity instruments around ‘average frequency’, ‘average size’, ‘number and type of active market participants’ and average size of spreads is also relevant to this chapter and we would welcome respondent’s views on any differences in how the trading obligation procedure should approach the following:

<ESMA_QUESTION_172>

AFME Response

172(i) Regarding ‘average frequency’ for FX, the GFXD would like to refer to our previous answer to question 103 of the Discussion Paper. Specifically, the GFXD agrees with ESMA in that the threshold would be set as a combination of the minimum number of transactions plus a minimum number of active trading days (i.e. a minimum number of transactions per day). A financial instrument would be considered liquid only if both requirements were met. Additionally, we suggest that it would be preferable to calculate the ‘average frequency’ using the number of transactions over a consecutive time period, the period being of sufficient time to allow the collated data to be normalized, considering disruption events or other events that cause unusual trading patterns.

172 (ii) For FX, the GFXD recommends that the time period will need to vary on an asset class basis (e.g. FX v Equity) due to the differing characteristics and trading patterns in each asset class. These are not homogenous.

172 (iii) For FX, the GFXD would like to refer to our previous answer to question 104 of the Discussion Paper in that the average size of transactions should be calculated by the total turnover over a period divided by the number of transactions in that period (i.e. the average turnover of transactions or AVT).

Given the unique nature of the FX market, in that it forms the basis of the global payments system, the market is typified as consisting of a high number of low notional transactions. We believe that the total turnover divided by the number of trading days method would give an artificially high representation of what could constitute an average transaction size and if implemented could unintentionally include illiquid trades in any calculations as being liquid.

172 (iv) For FX, the GFXD has performed additional analysis on the data collated in 2012 as part of the Financial Markets Lawyers Group (FMLG) analysis as part of The Foreign Exchange Committee and Financial Markets Lawyers Group Request for Interpretative Relief Regarding the Obligation to Provide Pre-Trade Mid-Market Quote under the CFTCs part 23 obligations. This data was based on a represented executable pricing data for select currencies (in order of market share EUR, AUD, MXN, TRY, TWD, ILS) supplied by major FX banks who participate on the FMLG based on ranking in the Bank for International Settlements (BIS) 31 CCYs compared to publicly available data published the same time on Bloomberg for the month of November 2012. Results for these currencies are illustrated in the tables below.

As a point of reference, according to the BIS Triennial Central Bank Survey Foreign exchange turnover in April 2013: preliminary global results report (<http://www.bis.org/publ/rpfx13fx.pdf>), the market share for the top 5 BIS currencies is: USD is (87%), EUR (33.4%), JPY (23%), GBP (11.8%) and AUD (8.6%).

In order to make the Bid-Ask spread more tangible, they have been converted into a dollar amount (per million USD of traded notional). The GFXD believes that by taking the Bid-Ask spread and converting it to a USD amount is more meaningful as this directly measures the economic impact of the Bid-Ask spreads.

Conclusions:

- Bid-Ask Spreads in USD terms: the dollar value of the Bid-Ask spread for the instrument, per million dollars notional and provides an indication of liquidity in the market. For instance, a 2Y ILS Forwards has a Bid-Ask of over USD 5,000, while a EUR/USD 6M forward has a Bid-Ask of less than USD 100 (50 times less). One of them is clearly very liquid, the other is not. This data is illustrated in Table 20.
- The ratio of Bid-Ask spread to mid, $[(Ask-Bid) / [(Ask+Bid)/2]]$: In FX, unlike some other asset classes, the relative size of the mid price compared to the Bid-Ask spread can distort the ratio and therefore provide an inaccurate representation of liquidity. This is illustrated in Table 21, we can see that by using this approach, USD/MXN appears to be more liquid than EUR/USD, due to the fact that the USD/MXN mid-point is circa 16 times larger than the EUR/USD mid, which is not reflected in the relative size of the Bid-Ask spreads. Consequently, the ratio proposed by ESMA is not a valid determination of relative liquidity in the FX market.

The GFXD recommended indicator of liquidity would therefore be to use a US dollar equivalent of the bid-ask.

Table 20: Results for the USD equivalent of the Bid-Ask spread, as defined in the previous section, both for forwards and options, and for 6m, 1Y and 2Y tenors.

| Forwards | | | | | | |
|-----------------------|---------|----------|----------|----------|----------|----------|
| 6M | EUR/USD | AUD/USD | USD/MXN | USD/TRY | USD/TWD | USD/ILS |
| Bid-Ask Spread | \$ 84 | \$ 99 | \$ 373 | \$ 1,432 | \$ 846 | \$ 768 |
| 1Y | EUR/USD | AUD/USD | USD/MXN | USD/TRY | USD/TWD | USD/ILS |
| Bid-Ask Spread | \$ 214 | \$ 328 | \$ 397 | \$ 2,479 | \$ 1,003 | \$ 1,537 |
| 2Y | EUR/USD | AUD/USD | USD/MXN | USD/TRY | USD/TWD | USD/ILS |
| Bid-Ask Spread | \$ 741 | \$ 1,145 | \$ 2,139 | \$ 5,063 | \$ 1,850 | \$ 5,869 |

| Options | | | | | | |
|-----------------------|----------|----------|-----------|----------|-----------|----------|
| 6M | EUR/USD | AUD/USD | USD/MXN | USD/TRY | USD/TWD | USD/ILS |
| Bid-Ask Spread | \$ 1,753 | \$ 1,798 | \$ 3,758 | \$ 5,420 | \$ 5,316 | \$ 3,673 |
| 1Y | EUR/USD | AUD/USD | USD/MXN | USD/TRY | USD/TWD | USD/ILS |
| Bid-Ask Spread | \$ 2,437 | \$ 2,558 | \$ 5,180 | \$ 4,530 | \$ 7,201 | \$ 5,166 |
| 2Y | EUR/USD | AUD/USD | USD/MXN | USD/TRY | USD/TWD | USD/ILS |
| Bid-Ask Spread | \$ 4,610 | \$ 4,896 | \$ 12,417 | \$ 9,218 | \$ 12,638 | \$ 6,537 |

Table 21: the ratio of Bid-Ask spread to mid as defined in the previous section, both for forwards and options, and for 6m, 1Y and 2Y tenors.

| Ratio of Bid-Ask spread to mid of Forwards | | | | | | |
|--|---------|---------|---------|---------|---------|---------|
| Tenor/Currency Pair | EUR/USD | AUD/USD | USD/MXN | USD/TRY | USD/TWD | USD/ILS |
| 6M | 4% | 1% | 2% | 6% | 10% | 13% |
| 1Y | 5% | 1% | 1% | 5% | 7% | 14% |
| 2Y | 8% | 2% | 3% | 5% | 9% | 27% |

| Ratio of Bid-Ask spread to mid of Options | | | | | | |
|---|---------|---------|---------|---------|---------|---------|
| Tenor/Currency Pair | EUR/USD | AUD/USD | USD/MXN | USD/TRY | USD/TWD | USD/ILS |
| 6M | 4% | 4% | 7% | 12% | 24% | 9% |
| 1Y | 3% | 3% | 6% | 10% | 21% | 8% |
| 2Y | 4% | 4% | 8% | 7% | 21% | 11% |

<ESMA_QUESTION_172>

Q173: Do you have a view on how ESMA should approach data gathering about a product's life cycle, and how a dynamic calibration across that life cycle might work? How frequently should ESMA revisit its assumptions? What factors might lead the reduction of the liquidity of a contract currently traded on venue? Are you able to share with ESMA any analysis related to product lifecycles?

<ESMA_QUESTION_173>

AFME Response

FOREIGN EXCHANGE

For FX, the GFXD has no view on how ESMA should approach data gathering about a product's life cycle and suggests that life cycle data is not relevant to FX.

<ESMA_QUESTION_173>

Q174: Do you have any suggestions on how ESMA should consider the anticipated effects of the trading obligation on end users and on future market behaviour?

<ESMA_QUESTION_174>

AFME Response

FOREIGN EXCHANGE

For FX, the GFXD recommends that ESMA studies the impact that the CFTCs trading obligation has had on the global FX markets, as well as the wider derivatives markets. ISDA have produced numerous reports which describe these impacts (<http://www2.isda.org/news/isda-publishes-research-note-analyzing-impact-of-mat-regulation-on-market-fragmentation>).

As discussed in our previous answers, the FX market forms the basis of the global payments system, it is characterized by a high number of market participants, is global in nature and executes across borders using many different execution venues. The GFXD strongly believes that financial regulations need to consider such factors and that global harmonization is required to prevent any unintended consequences, such as the fragmentation of market liquidity.

The GFXD also suggests that ESMA considers the financial implications that the regulatory agendas in both Europe and the rest of the world are having on market participants. Considering market turnover and the composition of market participants it is highly likely that a transaction will be exposed to the regulations of at least 2 separate jurisdictions:

- **Market turnover:** As mentioned previously, the Bank of International Settlements in their Triennial Central Bank Survey: Foreign Exchange Turnover in April 2013 (<http://www.bis.org/publ/rpfx13fx.pdf>) reported that 41% of the global FX market is executed in London, and collectively over 75% is executed from 5 global centres. The same report states that the US dollar was on one side of 87% of all transactions, and the euro on 33% of transactions.
- **Composition of the market:** Examining the market participants, and if we only consider the 23 global banks that the GFXD represents (as per Euromoney collectively they represent over 90% of the Inter-dealer market), then as each of these is registered as a US Swap Dealer they will have joint obligations in both Europe and the US.

Each regulatory obligation will incur a separate cost to market participants, and any difference in the same obligation will increase that cost, be it for pre/post trade reporting, a trading obligation or any other regulatory deliverable. These increased costs will be ultimately funded by one participant to the trade and it is likely that any 'available' funds will be required to be spent on im-

plementing regulatory obligations, rather than funding growth activities – ultimately impacting the wider growth agenda in Europe.

The GFXD commissioned Oliver Wyman to write a report (published in January 2012) on the impact of the proposed Financial Transaction Tax (FTT) in Europe (<http://gfma.org/correspondence/item.aspx?id=198>). Within that paper, reference is made to the attractiveness to doing business in Europe should transaction costs rise due to regulatory obligations. We feel that such analysis is applicable when considering the application of any European regulatory deliverables and the behavioural changes in the paper were characterized as follows:

- **Relocation:** The ability of organization to trade in different countries is of course dependant on the characteristics of the counterparty. Global dealer flows are portable, and could be estimated to be moved to the more favourable region, financial counterparties are again expected to be portable, whilst corporate and other non-financials are unlikely to be able to move
- **Substitution:** If market participants are not able to relocate, then there exists the possibility that they could trade different products that are not exposed to the same regulatory demands
- **Reduction in speculative trading:** The market may reduce its appetite for speculative trading and therefore reduce liquidity for end users such as corporates and other non-financials

Whilst this study focuses on the impact of a proposed FTT on the FX markets, we believe that the ‘attractiveness to business’ argument is portable across other regulatory deliverables that could increase costs to the end-user (such as a trading obligation). The report stated that for the FX markets in Europe, volume, by notional is split:

- 40% is dealer-to-dealer and it is estimated that 60-80% of this volume could be portable to regions outside of the EU
- 12% is dealer-to-hedge fund and it is estimated that 70% of such transactions could be portable
- 35% is remaining financial institutional trading, it is expected that 30-35% of such business could be portable
- 13% is dealer-to-corporate and it is estimated that 30-35% of such flow could move outside of the EU

This data suggests that a large % of FX activity currently executed in Europe could be portable to other jurisdictions outside of Europe. To try and size this number, the report also looks at the potential reduction in USD average daily volume. Again, this data was specifically used to demonstrate the impact of the FTT, but we feel that such information is portable to other regulatory deliverables that could have an increased financial cost on the end-user, illustrated below in Figure 1.

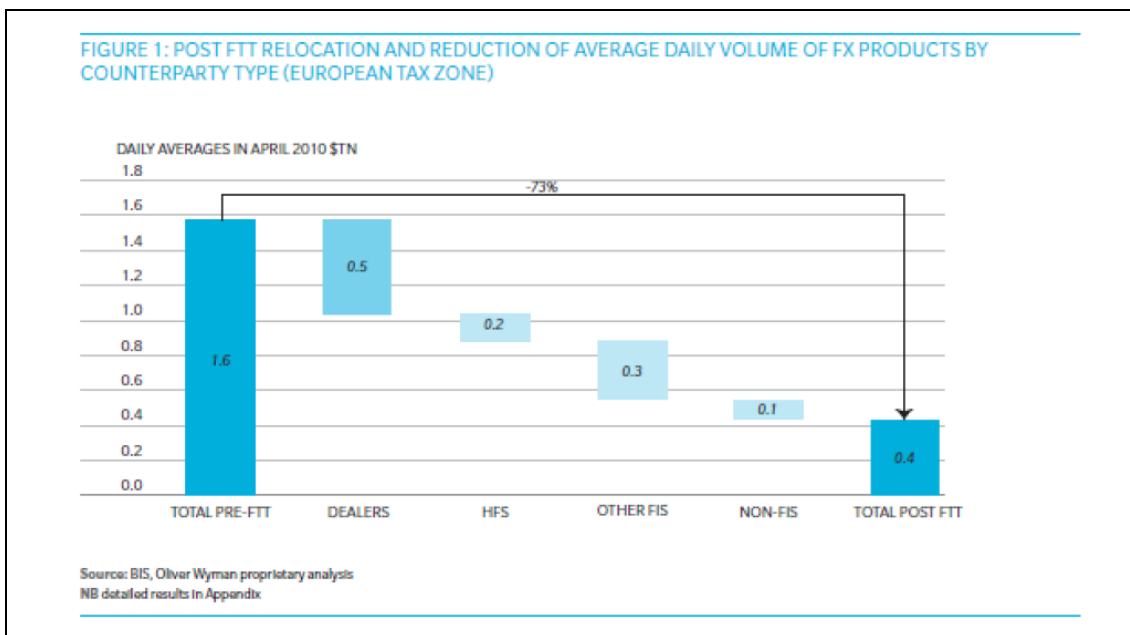

Finally, it should be reflected that any such shift in the trading practices of FX market participants could impact the oversight and control that central banks have on their respective currencies and market participants.

<ESMA_QUESTION_174>

Q175: Do you have any other comments on our overall approach?

<ESMA_QUESTION_175>

AFME Response

FOREIGN EXCHANGE

The GFXD does not have any further comments.

<ESMA_QUESTION_175>

3.12. Transparency Requirements for the Members of ESCB

Q176: Do you agree that the above identifies the types of operations that can be undertaken by a member of the ESCB for the purpose of monetary, foreign exchange and financial stability policy and that are within the MiFID scope? Please give reasons to support your answer.

<ESMA_QUESTION_176>

AFME Response

FIXED INCOME

Yes. AFME agrees with ESMA's approach that only a member of the ESCB is in a position to clarify whether a trade is for monetary, FX or FSB policy operations.

<ESMA_QUESTION_176>

Q177: What is your view about the types of transactions for which the member of the ESCB would be able to provide prior notification that the transaction is exempt?

<ESMA_QUESTION_177>

AFME Response

FIXED INCOME

Unfortunately, we do not believe that the test proposed by ESMA is workable in practice. In order for the exemption to be workable, the clarification must be provided prior to or at the point of execution. This is because the investment firm/venue must know whether to apply the transparency requirements prior to execution (the transparency requirements need to be complied with prior to execution and after execution but before settlement). However, legal documents are exchanged on the settlement date (i.e. two days or more after execution of the trade). Therefore, ESMA's proposed clarification could only occur after the transparency requirements would need to be met.

We propose that either (i) the member of the ESCB provides a clarification when requesting a quote, which would require operational builds (special flags) and there would also be transparency compliance concerns for investment firms/venues (i.e. how would they demonstrate that the ESCB has provided the clarification and thereby complied with the transparency requirements); or (ii) the request for the quote by the member of the ESCB should be taken as prima facie evidence that the trade is for monetary, FX or FSB policy operations.

AFME recommends the second option.

<ESMA_QUESTION_177>

3.13. Article 22, MiFIR: Providing information for the purposes of transparency and other calculations

Q178: Do you have any comments on the content of requests as outlined above?

<ESMA_QUESTION_178>

AFME Response

FIXED INCOME

We note that it will be highly challenging for ESMA to collect accurate and appropriate data for the purposes of calibrating the SI and liquidity calibrations, especially if a centralised infrastructure is not put in place. We emphasise that ESMA should give careful thought to how it intends to collect data from all appropriate sources, such that the information it collects is accurate and pertains to the entire market (and not just a subset that would skew the results) – the SI and liquidity calculation is dependent on ESMA producing high quality and complete pan European data. ESMA needs to have a way to collate European-wide data correctly and from all venues. AFME provides its recommendations and ideas below as to how this could be achieved.

As ESMA has observed, the content of the data templates for the purposes of Article 22 depend on the calibration regimes. Our proposals are based on the key aspects of AFME's proposals for the liquidity and SI calibration:

- An IBIA approach is necessary for bonds and SFPs;

- Calibration should be based on European-wide calculations of ADT, frequency of trades, number of market participants and spread; and
 - Calibration is undertaken on a dynamic monthly basis for liquidity and quarterly for SI.
- (i) To ensure data can be consolidated for the production of a calibration, ESMA needs to ensure that the data is non-duplicative and is of good quality, which can be achieved through a clear data quality protocol**

We strongly suggest for there to be trade publication protocols in place to ensure that post trade information is not of poor quality. Therefore, we have proposed an expanded list of fields (public and non-public fields) when a firm chooses to have the APA apply the data protocols (as set out in our response to **DP Questions 132, 178 and 361**). If the investment firm does not apply the protocols, it will need to apply the protocols in-house using the same data fields.

We recommend that this can be achieved by having clear data quality protocols in place whereby each individual transaction shall be made public once through a venue and if the trade isn't on venue, through a single APA (as required under Article 21(2)) – this will enable each data set provided by each venue or APA for the purposes of calibration to be unique and consolidatable.

The protocol that we propose is

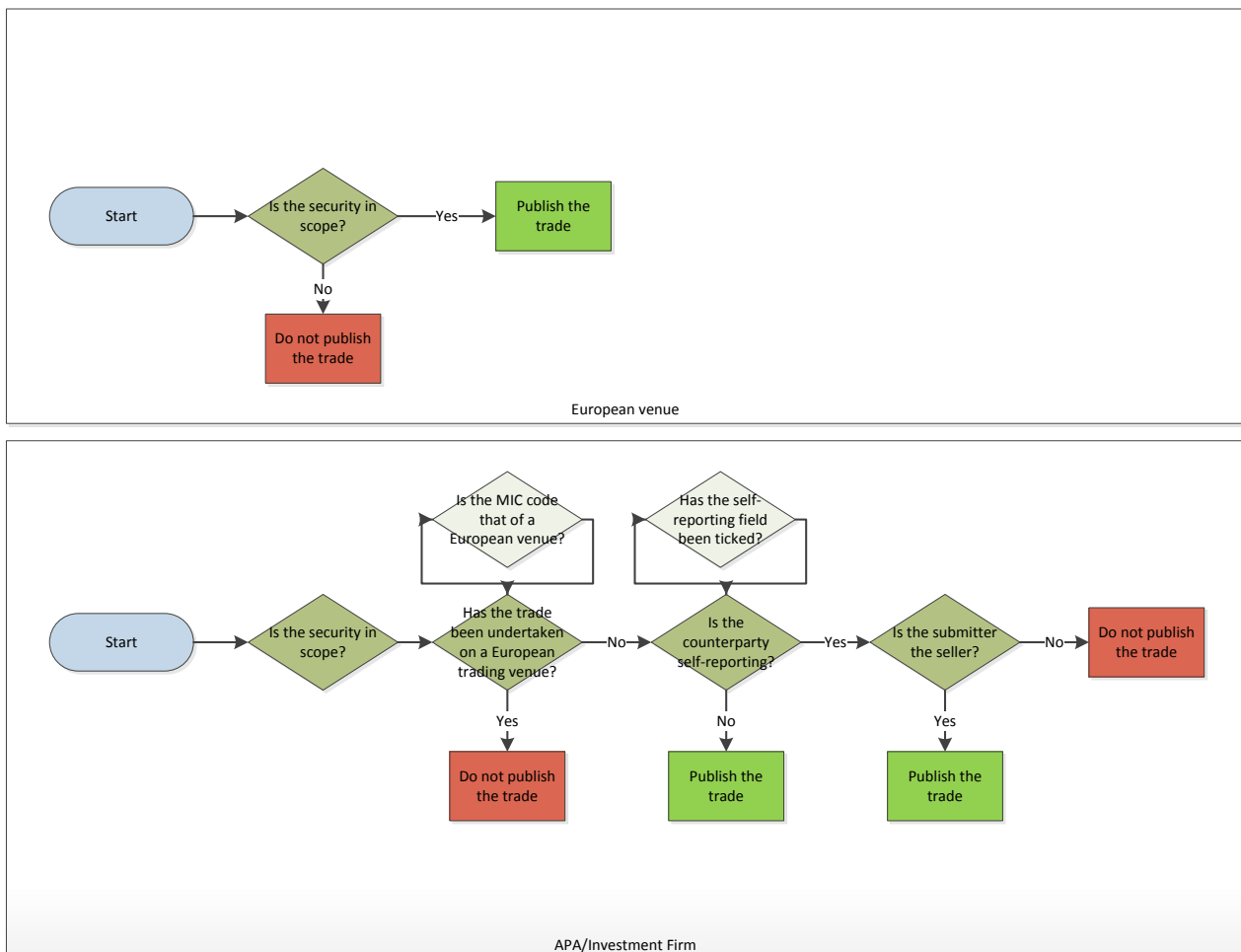

The waterfall works as follows: (i) European venues always publish their trades; and (ii) the APA receiving the information from an investment firm or the investment firm applies the following logic:

- If the trade has been undertaken on a European venue, the APA should not publish the trade/the investment firm should not submit the trade to the APA – **the trade should be suppressed**
- If the trade has not been undertaken on a European trading venue, if the counterparty of the submitting investment firm/of the investment firm is not a self-reporting entity, then the APA should publish the trade/the investment firm should submit the trade to the APA – **the trade should be published**; and
- If the counterparty of the submitting investment firm/of the investment firm is a self-reporting entity, the APA should only publish the trade/the investment firm should only submit the trade to the APA if the investment firm is the seller

(ii) Since each APA and venue publishes unique data sets, these entities can submit aggregate data to NCAs, which can in turn be aggregated

We believe that the calibration exercises can be highly data intensive but does not need to be. Since each APA and venue publishes unique data sets, these entities can submit aggregate data to NCAs, which can then be easily aggregated.

For example, for the calculation of ADT and trading frequency, venues and APAs simply need to provide by ISIN, the total number of trades and the total volume of trades. ESMA then simply needs to add up the aggregate reports, which is not complex or operationally onerous. We do note, however, the quality of the aggregate reports and the final aggregate data used by ESMA to produce the calibrations that will be dependent on the consistency of application of the data quality protocols.

The aggregation protocol is illustrated below:

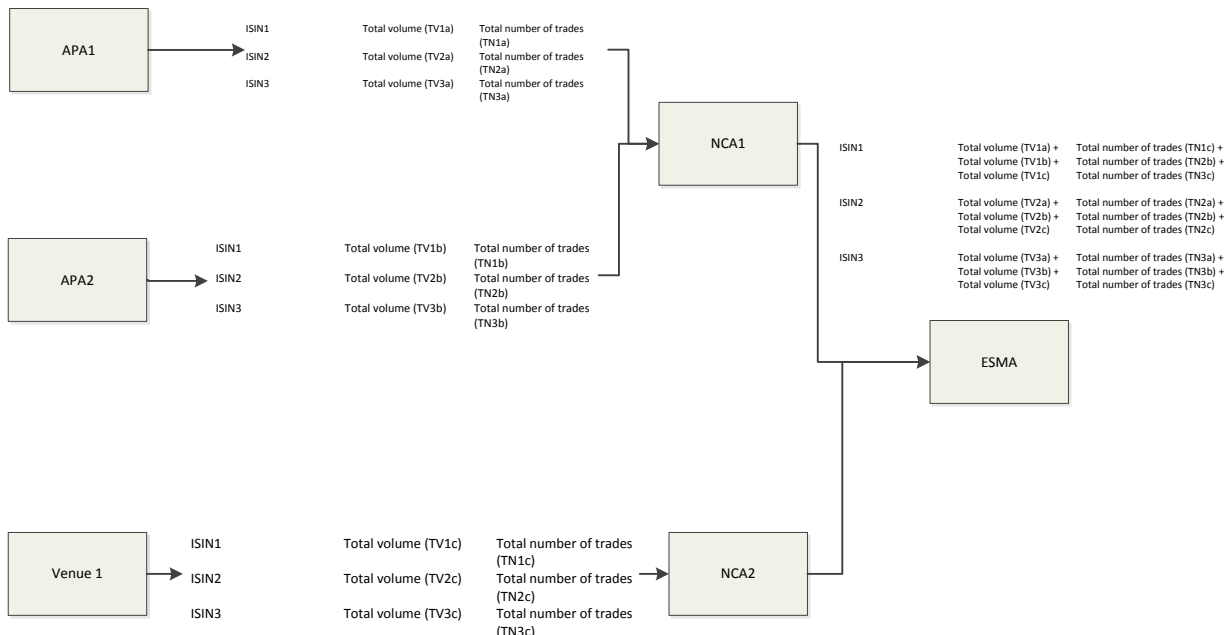

For the calculation of ADT and frequency of trades, AFME proposed APAs to submit data in the following template on **a monthly basis** on trades that are publishable by the APA and venue (i.e. not suppressed trades as a result of the waterfall or technical trades):

| ISIN code | Total volume traded (converted to EUR) | Total number of trades |
|-----------|--|------------------------|
| | | |
| | | |
| | | |

ESMA will only then need to aggregate these templates across the different venues and APAs. After aggregating the information, ESMA needs to publish the calibration in a machine readable way to all market participants.

Whilst it is essential that ISINs are used to achieve standardization, we highlight that a significant portion of ISINs are not freely available. Specifically, there are costs and licensing constraints associated with ISINs listed in the US and Canada, which are structured to contain an embedded CUSIP within the ISIN structure that causes CUSIP issuers to demand licenses from companies that redistribute the ISINs within their reporting templates.

(iii) Centralised calibration is critical

We believe that the importance of developing an economically sound MiFID regime for fixed income outweighs the costs to development of supporting infrastructure by regulators and industry. ESMA has identified that the liquidity calibration should be based on frequency of trades and ADT, which are European-wide parameters. In-on-of-itself, such a calibration would need to be undertaken centrally – such a calibration cannot be undertaken at NCA or investment firm level. Further, given the liquidity-sensitive nature of fixed income instruments, we believe the maintenance of a single central list of instruments is more critical for fixed income and is unavoidable. Simply because the scale of the application of MiFID to fixed income is greater than for equities, does not justify infrastructure that is not fit for purpose. AFME strongly recommends that the regime is calibrated through a single central calibrating entity for maintaining all static and reference data as well as undertaking dynamic calibration that uses data from the entire European market. Having NCAs collecting the same data and undertaking the same calculations individually will result in an inconsistent, unworkable and highly fragmented regime. Such a fragmented regime is in direct contradiction of the objectives set out in MiFIR (Recital 2) to: *“In the context of the future European supervision architecture, the European Council of 18 and 19 June 2009 stressed the need to establish a European single rule book applicable to all financial instruments in the internal market”*. Given the inevitable operational need for a centralised calibration (based on the other proposals of ESMA for fixed income), we believe a more dynamic approach calibrated at instrument level would be operationally feasible (please see AFME’s responses to **DP Questions 132 and 178**).

(iv) It is critical that ESMA is clear about what transactions should contribute to the calculations and ensures that the data is received from trading venues/APAs/CTPs only reflects such transactions

As discussed in response to **DP Question 135**, it is essential that ESMA clarifies which transactions should be included in the calculations and how that data should be presented/standardised. Providing clear definitions and processes is critical – it is essential that all firms/venues/APAs populate fields/flags consistently. We emphasise that our recommendations in response to **DP Question 135** apply to Section 3.13. Some examples are provided below:

With regards to trades that we recommend to be out of scope for the purposes of calibration: we believe that transactions determined by other factors than the valuation of the instrument. Under Article 21(5)(b), ESMA has been asked to determine the application of the post trade transparency requirements to “*transactions involving the use of those financial instruments for collateral, lending or other purposes where the exchange of financial instruments is determined by factors other than the current market valuation of the financial instrument.*” We recommend that, in line with ESMA’s recommendations for SFT transactions, other trades that are not price forming should also be out of scope. For example, technical trades (such as interaffiliate transactions undertaken for the purposes of risk management) should not be published. Publication of non-price forming trades would not provide informational value for the purposes of price discovery and would be distortive.

AFME also believes that reporting primary trades could prove misleading where you would end up with lots (often hundreds) of late booked trades (after pricing and syndicate allocations had been determined) either with spurious trade times (reflecting booking time which often runs into the night) or simply very late bookings (certainly not anywhere near 5 minutes of execution). In addition, these trades are not price determining, at this stage everyone is a price taker. The consolidated tape would show a significant distortion in the market and exaggerate liquidity from a calibration perspective (the bond could in practice be totally illiquid post trade date if locked up by the buy-side).

Further, for calculations involving trade count, the calculation of average frequency of transactions, it is essential that block-level trades are used rather than allocations. Even though matching is a very important process, it is essential that the allocations are not included in the trade frequency count. Rather, it should be the block level trades that are counted. For example, if a bank undertakes a trade of EUR 50mm notional with a client and that client allocates the EUR 50mm to 100 different funds, the trade count should be one (one trade of EUR 50mm and not 100 trades of EUR 500,000). Counting at the allocation level would be misleading and would incorrectly inflate the number of trades. It is essential that this is clarified by ESMA.

<ESMA_QUESTION_178>

Q179: Do you have proposals on how NCAs could collect specific information on the number and type of market participants in a product?

<ESMA_QUESTION_179>

AFME Response

FIXED INCOME

As proposed by AFME in response to Question 105, we propose for the number of market participants to be based on the number of participants on venue rather than the whole market – venues will simply have to provide the list of LEIs per instrument (i.e. participants that have traded in that instrument in the given period). This will be operationally simpler.

Alternatively, if ESMA calibrates the number of market participants based on all counterparties to that instrument in a given period on and off venue, APAs will need to collect LEI data from investment firms submitting the information, produce aggregate LEI reports for each instrument, which will then need to be consolidated centrally.

<ESMA_QUESTION_179>

Q180: Do you consider the frequency of data requests proposed as appropriate?

<ESMA_QUESTION_180>
TYPE YOUR TEXT HERE



<ESMA_QUESTION_180>

Q181: How often should data be requested in respect of newly issued instruments in order to classify them correctly based on their actual liquidity?

<ESMA_QUESTION_181>

AFME Response

FIXED INCOME

No. AFME proposes for APAs and venues to provide NCAs with at least monthly data submissions – since the calibration AFME is proposing is month-end. It is far more complex to request irregular reports than reports that need to be provided at regular set dates. We propose that an automated system will enable the reports to be aggregated quickly and easily (we suggest that a live feed is necessary between the NCAs and ESMA – otherwise bottlenecks will appear in the calibration process).

<ESMA_QUESTION_181>

Q182: What is your view of ESMA’s initial assessment of the format of data requests and do you have any proposals for making requests cost-efficient and useful for all parties involved?

<ESMA_QUESTION_182>

AFME Response

FIXED INCOME

AFME agrees with ESMA’s initial assessment. We suggest ESMA investigates whether the FIX protocol is a viable option. Standard market formats should at least be used (e.g. XML).

<ESMA_QUESTION_182>

Q183: Do you consider a maximum period of two weeks appropriate for responding to data requests?

<ESMA_QUESTION_183>

AFME Response

FIXED INCOME

No. AFME disagrees.

As discussed in response to DP **Question 180**, we propose for APAs and venues to provide NCAs with at least monthly data submissions – since the calibration AFME is proposing is month-end.

It is far more complex to request irregular reports than reports that need to be provided at regular set dates. Therefore, rather than ESMA requesting information on an ad-hoc basis, venues and APAs should be required to produce regular reports to be submitted on preset dates. This is far more operationally simple and more cost-effective.

<ESMA_QUESTION_183>

Q184: Do you consider a storage time for relevant data of two years appropriate?

<ESMA_QUESTION_184>

AFME Response



FIXED INCOME

Yes. AFME agrees.

<ESMA_QUESTION_184>

4. Microstructural issues

4.1. Microstructural issues: common elements for Articles 17, 48 and 49 MiFID II

Q185: Is there any element that has not been considered and/or needs to be further clarified in the ESMA Guidelines that should be addressed in the RTS relating to Articles 17, 48 and 49 of MiFID II?

<ESMA_QUESTION_185>

AFME Response

AFME is very concerned that there is a stacking of investment firm responsibilities with those of national competent authorities (NCAs), direct electronic access (DEA) providers, clearers and trading venues (TVs): the regulation should seek to avoid that in addition to an NCA checking firms' compliance, DEA providers, clearers and trading venues will do the same work, individually and all in different formats at different moments (but as proposed, at least twice a year) in order to satisfy their own requirements.

Forcing trading venues and DEA providers to audit or review their counterparties, i.e. investment firms, in order to be compliant themselves, on top of the primary obligations of investment firms would mean investment firms may become subject to audits and inquiries from numerous trading venues and service providers, at least twice a year, leading to immense documentary exercises without any tangible benefits. This might entail endless paper pushing without any real benefit and will be an onerous demand on firms' resources. This will also put small-to-medium sized firms at an unnecessary implementation disadvantage: it will take them just as much work to go through the process as it will large firms. To the extent any regulatory obligations overlap, investment firms should be able to satisfy these to the NCA and use a confirmation of good standing or the DEA user's own authorisation as a 'central point of approval' for DEA providers, clearers and trading venues.

Additionally requirements in general do not appear proportional. A proportional application of the Guidelines should take into account the nature, scale and complexity of different businesses. By definition, this should encompass some flexibility for firms to exercise discretion as to which, and to what extent, requirements apply to their businesses. While ESMA explicitly states it "recognises that the risks stemming from algorithmic trading activities (for firms themselves and/or for the fair and orderly functioning of markets) are not homogenous across all firms," ESMA has nevertheless removed any discretion for firms when it goes on to state that the extensive list of organisational requirements in the following section "should constitute a minimum." We believe this statement is fundamentally contrary to the proportionality principle. Therefore, we recommend ESMA adopt an approach that simplifies the nature, scale and complexity factors and requires reviews 'annually or more frequently if circumstances give rise.' In conducting a holistic business review, our view is that organisations will not likely change significantly every six months. A more frequent self-assessment should be undertaken only in the event of a material change in the nature, scale, and complexity of the investment firm.



<ESMA_QUESTION_185>

Q186: Do you agree with the definition of ‘trading systems’ for trading venues?

<ESMA_QUESTION_186>

AFME Response

Yes

<ESMA_QUESTION_186>

Q187: Do you agree that the requirements under Articles 48 and 49 of MiFID II are only relevant for continuous auction order book systems and quote-driven trading systems and not for the other systems mentioned above?

<ESMA_QUESTION_187>

AFME Response

Yes

<ESMA_QUESTION_187>

Q188: Which hybrid systems, if any, should be considered within the scope of Articles 48 and 49, and why?

<ESMA_QUESTION_188>

TYPE YOUR TEXT HERE

<ESMA_QUESTION_188>

Q189: Do you agree with the definition of “trading system” for investment firms?

<ESMA_QUESTION_189>

AFME Response

Overall AFME has concerns as to the implications on the SI structure and how it would work with such a definition. Additionally we would like to seek clarification as to the meaning of ‘high frequency generation of orders’. In the context of the definition, would anything which was not deemed ‘high frequency’ mean it would not be classed as falling under the definition of ‘trading systems for investment firms’?

Only systems that generate/initiate orders should be in scope (i.e. not an investment firms back office). Systems that receive orders should be excluded (e.g. Pre-/post trade)

FOREIGN EXCHANGE:

For FX, the GFXD agrees with the above definition for instruments in scope as defined in MiFID Annex C4. Where instruments fall out of scope of the definition of financial instruments these requirements will not apply.



Finally, for the Microstructural Issues section of the Discussion Paper, unless the GFXD has submitted a specific response for FX, the GFXD supports the submissions made by the Association for Financial Markets in Europe (AFME).

<ESMA_QUESTION_189>

Q190: Do you agree with the definition of ‘real time’ in relation to market monitoring of algorithmic trading activity by investment firms?

<ESMA_QUESTION_190>

AFME Response

At the point at which a problem is manifest, under the continuous monitoring regimes that investment firms already employ it is expected that an alert would be generated within 5 seconds and appropriate action then taken where necessary. However it should be noted that 5 seconds is nevertheless a short period of time. AFME would seek clarification as to what is deemed to be an ‘appropriate action’ in this instance.

FOREIGN EXCHANGE

For FX the GFXD agrees with the above definition for instruments in scope. Generally, Investment firms already have existing policies, procedures and controls in place to monitor algorithmic trading across all instruments.

<ESMA_QUESTION_190>

Q191: Is the requirement that real time monitoring should take place with a delay of maximum 5 seconds appropriate for the risks inherent to algorithmic trading and from an operational perspective? Should the time frame be longer or shorter? Please state your reasons.

<ESMA_QUESTION_191>

AFME Response

See response to question 190 above

FOREIGN EXCHANGE:

For FX the GFXD agrees with the above requirements for instruments in scope. Generally, Investment firms already have existing policies, procedures and controls in place to monitor algorithmic trading across all instruments.

<ESMA_QUESTION_191>

Q192: Do you agree with the definition of ‘t+1’ in relation to market monitoring of algorithmic trading activity by investment firms?

<ESMA_QUESTION_192>

AFME Response

No. Although we would agree with the definition from an equities perspective we would note that from a fixed income perspective this may be more challenging to carry out. When looking at market monitoring of algorithmic trading activity for fixed income by investment firms 't+1' seems ambitious. It is the current state of play that underlying data is available from trading venues on the next trading day. Therefore it would be more efficient to have t+1 apply to the end of the following trading day in order to receive the underlying data from the trading venues and subsequently (at the end of that trading day) be able to monitor algo trading activity. The exchange dependency on some data would make T+1 as it is defined (i.e. at the start of the next trading day) very inefficient in terms of data collection and submission.

FOREIGN EXCHANGE:

For FX, the GFXD does not agree with this definition and would like to reference that specifically for FX that the FX market operates globally, on a cross jurisdictional basis, is open 24 hours a day, for 5.5 days of the week. The market does not operate to pre-determined open/close times and it is not appropriate to apply a T+1 rule based on 'before market opening'.

<ESMA_QUESTION_192>

Q193: Do you agree with the parameters to be considered to define situations of 'severe market stress' and 'disorderly trading conditions'?

<ESMA_QUESTION_193>

AFME Response

No. From a fixed income perspective AFME would like to note the following:

Severe Market Stress: members feel that the definition used for 'severe market stress' seems slightly ambiguous even in the context of Article 17. Market stress is not a system capacity e.g. an increased message count has no relation to market stress and we would thus see this as a flawed indicator of such 'severe market stress'. AFME members feel that this should be related to the liquidity work being carried out under MiFID II and should not be related to IT system requirements or capacities.

Disorderly Trading Conditions: Clarity is sought as to the definition of 'disorderly' and how this would be quantified, evaluated and how long a market must be 'disorderly' to be determined to be a 'disorderly trading condition'. There may be fluctuations in market activity such as monthly ECB announcements which could lead to slight fluctuations in the market however this should not be seen as a 'disorderly trading condition'. It is difficult to 'test' a disorderly trading condition and by way of its current definition it is not clear what would constitute a 'disorderly' market condition.

FOREIGN EXCHANGE:

For FX, the GFXD does not agree with the text and believes that the definition of 'severe market stress' as currently stated in the proposal as "...increase in the number of messages being sent to and received from systems of one trading venue causing a risk to the systems performance" is limited and cannot be only a quantitative measure.

FX is a highly electronic and global market. Market Stress can be triggered by external or economic distress events that can lead to drop in liquidity leading to "severe market stress" and "disorderly trading conditions". GFXD recommends the use of both qualitative and quantitative



factors to measure such conditions and should not be limited to the measures defined in the proposal.

<ESMA_QUESTION_193>

Q194: Do you agree with the above approach?

<ESMA_QUESTION_194>

AFME Response

No. Overall we have no concerns with the approach as proposed. However, in relation to questions and proposals which are focused on requirements of trading venues it seems most appropriate for trading venues to address these questions. However we would like to note that it should be considered that a third party or an EU authority should carry out assessments of trading venues rather than trading venues carrying out self assessments. It is a concern that there may not be a clear differentiation between trading venues when such a self assessment in terms of nature, scale and size takes place. Some smaller venues will have different data and monitoring systems/capabilities than larger trading venues.

<ESMA_QUESTION_194>

Q195: Is there any element that should be added to/removed from the periodic self-assessment?

<ESMA_QUESTION_195>

AFME Response

No

<ESMA_QUESTION_195>

Q196: Would the MiFID II organisational requirements for investment firms undertaking algorithmic trading fit all the types of investment firms you are aware of? Please elaborate.

<ESMA_QUESTION_196>

AFME Response

No. AFME consider that, in terms of fixed income particularly, not all investment firms are equal based on their size and trading activity in certain instruments. Larger sell side firms will be fairly homogeneous in terms of algo flow compared to smaller firms who may vary in terms of their algo flow intra-day.

<ESMA_QUESTION_196>

Q197: Do you agree with the approach described above regarding the application of the proportionality principle by investment firms? Please elaborate.

<ESMA_QUESTION_197>

AFME Response

No. Please see response to question 185 above.

Annually would be more appropriate given the nature of the investment firm is unlikely to change that significantly within a 6 month period.

The concept of proportionality should also be able to be applied on an activity by activity basis. Some activities may require a high degree of organisational oversight, but others less so.

<ESMA_QUESTION_197>

Q198: Are there any additional elements that for the purpose of clarity should be added to/removed from the non-exhaustive list contained in the RTS? Please elaborate.

<ESMA_QUESTION_198>

AFME Response

No. However, it is felt that an aggregated volume activity would be better suited rather than the requirements to provide a monetary value. Modelling pricing risks and the building of algos could be difficult and would lead to commercially sensitive information being made public.

<ESMA_QUESTION_198>

4.2. Organisational requirements for investment firms (Article 17 MiFID II)

Q199: Do you agree with a restricted deployment of algorithms in a live environment? Please elaborate

<ESMA_QUESTION_199>

AFME Response

From an equities perspective this is agreeable subject to the concerns raised in the responses to questions 201 and 202 below. However AFME would like to note that from a fixed income perspective AFME seeks clarification on the term 'restricted' for example is this in reference of only using a certain amount of liquidity during the trading day? Alternatively would this refer to total volume and firms only trade a 'restricted' proportion of this intra day? When conducting testing in a live environment clarification is sought as to the timeframe of this testing so as not to disrupt the market.

FOREIGN EXCHANGE

For FX, the GFXD does not agree with a prescriptive deployment of algorithms in a live environment. The FX marketplace is global and highly electronic operating 24 hours a day for 5.5 days of the week and due to the large number of market participants and their varied nature has resulted in the establishment of multiple smaller platforms that offer niche services and help dissipate concentration risks within the FX markets. Such smaller platforms are not as well suited as the larger platforms (such as the LSE in the equity markets) and as such are not resourced to provide the suitable resources required to enable live testing.

The GFXD is concerned that the support required at both the ECN and the investment firm is significant, as new processes and increased operational risks will need additional support and



suggests that ESMA considers this in its assessment of what testing is required. The GFXD suggests that any testing requirements take into account the special features of the venues in a proportionate manner.

<ESMA_QUESTION_199>

Q200: Do you agree with the parameters outlined for initial restriction? Please elaborate.

<ESMA_QUESTION_200>

AFME Response

AFME agrees in principle with the parameters for the controlled roll-out of algorithms but not all criteria can be applied in all cases. AFME would expect investment firms to have discretion on which limits are appropriate to be applied in any one roll out <ESMA_QUESTION_200>

Q201: Do you agree with the proposed testing scenarios outlined above? Would you propose any alternative or additional testing scenarios? Please elaborate.

<ESMA_QUESTION_201>

AFME Response

No. Subject to comments in responses to questions 200 and 202. Although members are in support of testing being carried out to ensure the efficient and orderly functioning of the markets (and investment firms already have in place quality testing as part of their IT development processes), the practicability of trying such intensive testing could be difficult. The build out implications at an investment firm level will be substantial and timely. In relation to production like liquidity, not all venues offer this form of testing environment at present especially not smaller trading venues as for them this form of testing would be more challenging operationally than for larger trading venues. In line with other testing timeframes AFME would strongly note once more that testing on an annual basis would be best suited.

During high volume intra-day it may also be more difficult to devise a test system to handle such situations. Adopting some form of replay capabilities would be a possible suggestion so as to carry out testing scenarios without affecting the market intra-day. Members would be able to comply with such testing should trading venues be able to provide such simulated environments, which currently they do not do.

It is worth noting that in some instances testing in line with the 'proportionality principle' is not possible. As an example for fixed income, in the case of small changes in algos which are expected to trade at very low levels such as once per week. The intensity therefore of having a three stage testing procedure for minimal procedures and changes in algos would not be practicable.

FOREIGN EXCHANGE

For FX, the GFXD would like to additionally add, specifically for the FX markets, that as FX is a global market, operating on a cross jurisdictional basis that any algo pre-trade controls or additional testing requirements should be applied consistently across global jurisdictions to prevent any market fragmentation, essentially favoring market participants that operate in regions with less stringent regulatory requirements. Additionally, complexity and different requirements set out by each regulatory authority could potentially add operational risk to the environment.



<ESMA_QUESTION_201>

Q202: Do you agree with ESMA’s approach regarding the conditions under which investment firms should make use of non-live trading venue testing environments? Please elaborate.

<ESMA_QUESTION_202>

AFME Response

No. Members are in agreement that it makes sense for investment firms to remain responsible for assessing the testing results and making changes to the algorithm, trading strategy or system as appropriate. However in terms of managing accuracy and stability for the trading venues it is felt that this responsibility lies with the trading venues themselves and not with the investment firms.

AFME considers that the requirement proposed in Paragraph 7 that “non-live testing should be performed for each individual market that a firm intends to access, i.e making use of the specific non-live trading venue testing environment for that market” is overly prescriptive in light of the benefits that it might bring.

The EU trading venues in which the majority of trading algorithms operate are very homogenous in the way that they operate. Indeed many individual markets operate on identical platforms (e.g Euronext). This homogeneity provides for the economies of scale that allow investment firms to provide cost-effective execution services to their clients across the continent.

The majority of differences between individual EU trading venues lie in the messaging protocols used by the venues to transmit market data and receive orders. In reality, trading algorithms used by AFME members rarely deal with these protocol differences directly: These tasks are performed by dedicated infrastructure which “normalises” the differences in venue-protocols and presents the trading algorithm with a common interface to all venues. Naturally such pieces of exchange-facing infrastructure must be tested thoroughly against each individual market that they interact with. AFME recognises that are situations where algorithms themselves must be adapted to the individual micro-structure of a market and that these situations should be tested with the relevant market. In other cases, however, testing an algorithm against every venue that it will send orders to will provide little benefit in terms of exercising generic code. AFME considers that overly prescriptive testing practices may inadvertently create a “Box Checking” culture in which the testers’ attention is diverted from exercising reasonable discretion as to how to eliminate risk efficiently.

AFME recognises the importance of testing in a non-live environment but would suggest that this requirement be modified to include “testing on a sufficient number of live testing environments to adequately represent the breadth of market structures to which the algorithm must adapt”

<ESMA_QUESTION_202>

Q203: Do you consider that ESMA should specify more in detail what should be the minimum functionality or the types of testing that should be carried out in non-live trading venue testing environments, and if so, which?

<ESMA_QUESTION_203>



AFME Response

No. Ensuring that trading venues carry responsibility for their own accuracy and stability management.

<ESMA_QUESTION_203>

Q204: Do you consider that the requirements around change management are appropriately laid down, especially with regard to testing? Please elaborate.

<ESMA_QUESTION_204>

AFME Response

Yes

<ESMA_QUESTION_204>

Q205: Do you agree with the proposed monitoring and review approach? Is a twice yearly review, as a minimum, appropriate?

<ESMA_QUESTION_205>

AFME Response

No. Members feel that in line with other 'testing' requirements noted in the DP an annual monitoring and review approach would be appropriate also in this context. It is felt particularly for fixed income and in line with the market environment that the environment does not change quickly enough to warrant a twice yearly review and monitoring approach.

In relation to 'low granularity' we would seek clarification as to the intended meaning of this phrase and what the requirements are for 'low granularity'. Additionally the real time aggregation and exposure of traders and clients is operationally challenging and we would ask you to revert to our response in questions 190.

The same risk monitoring systems should be applied to trading venues as well as investment firms to cover all market participants. Consideration should also be given to orders entered manually and what the implications on a risk monitoring system would be should manual orders also be considered in scope.

<ESMA_QUESTION_205>

Q206: To what extent do you agree with the usage of drop copies in the context of monitoring? Which sources of drop copies would be most important?

<ESMA_QUESTION_206>

AFME Response

AFME agrees with the necessity to reconcile and that reconciling trading logs with those of its partners is appropriate risk management, however AFME does not believe that only drop copies



are available to achieve this aim. Firms would not expect a full risk assessment in all circumstances as this very much depends on the frequency of trades occurring particularly by way on fixed income. The higher the frequency the more drop copies are generated, however with a lower frequency these may become a manual process. This would therefore also depend on what instruments you are trading and tie in with liquidity (as previously noted liquidity in the fixed income markets is different to that in the equities markets). As the frequency of trades increases the manual process would not be plausible however to require drop copies for all activities without taking into account the frequency of trades carried out would seem excessive.

<ESMA_QUESTION_206>

Q207: Do you agree with the proposed approach?

<ESMA_QUESTION_207>

AFME Response

Yes

<ESMA_QUESTION_207>

Q208: Is the proposed list of pre trade controls adequate? Are there any you would add to or remove from the list?

<ESMA_QUESTION_208>

AFME Response

No. AFME believes that some metrics (para 62 (iv) and (v) in particular) could be managed on a near real time basis as they may require consolidation of data spread across several systems. AFME furthermore seeks clarification as to whether this is worth taking into account the size of the firms in question or alternatively the volume traded to determine which pre trade controls may be adequate.

Regarding iv, typically clients would be limited in terms of exposure they may take overall but would still need to consolidate data across a number of markets and to an extent on a cross product basis (example ADR vs ORD). Such metrics are more accurately managed on a real time post trade basis than on a pre trade basis allowing scalability across venues and products. Metrics allocated to Options should not be directly related to order entry (i.e. volume, notional, price tolerance) and be monitored real time and trigger cancellation/suspension of trading rather than strictly request pre trade controls.

<ESMA_QUESTION_208>

Q209: To what extent do you consider it appropriate to request having all the pre-trade controls in place? In which cases would it not be appropriate? Please elaborate.

<ESMA_QUESTION_209>

AFME Response

AFME believes only a subset of these metrics should be made mandatory in all cases: Para 62 (i) price collars, so as to prevent triggering circuit breakers on exchanges; (ii) maximum order



value*; or (iii) volume or lots (normalised for the liquidity of the security); (vii) kill buttons, as it is essential to be able to prevent order entry in some cases.

* Value thresholds are difficult to apply to some types of instrument - such as futures.

The remainder of the metrics should be enforced either on a pre trade basis or on a real time post trade basis but should not be made mandatory to implement as a pre trade checks per se. In addition, they may be difficult to implement without risks in some cases. For instance, when an exchange connection is shared between DEA users, the number of messages sent to an exchange is function of clients and would not be easily predictable. An execution throttle could prevent a firm from being able to adjust its risks at critical points and have the inverse effect. In addition we believe such controls are redundant taking into account ESMA's proposal to obligate the exchange to monitor and throttle their member connections. We would, however, be supportive of the obligation to monitor such metrics near real time and believe it would bring a more flexible and appropriate framework to a sound risk management policies.

<ESMA_QUESTION_209>

Q210: Do you agree with the record keeping approach outlined above?

<ESMA_QUESTION_210>

AFME Response

No. AFME is concerned about the complexity/need to relate record keeping with individual parameters, unless parameters already subject to change control, and that the approach is far too granular.

<ESMA_QUESTION_210>

Q211: In particular, what are your views regarding the storage of the parameters used to calibrate the trading algorithms and the market data messages on which the algorithm's decision is based?

<ESMA_QUESTION_211>

AFME Response

AFME is concerned about the complexity/need to relate record keeping with individual parameters, unless those parameters are already subject to change control. AFME believes that the approach is far too granular.

<ESMA_QUESTION_211>

Q212: Do you consider that the requirements regarding the scope, capabilities, and flexibility of the monitoring system are appropriate?

<ESMA_QUESTION_212>

AFME Response



We are concerned that ESMA is introducing a new mandatory requirement for automated monitoring in paragraph 88 which could be potentially extremely burdensome for firms.

<ESMA_QUESTION_212>

Q213: Trade reconciliation – should a more prescriptive deadline be set for reconciling trade and account information?

<ESMA_QUESTION_213>

AFME Response

No we don't believe this is necessary – firms will need some discretion.

<ESMA_QUESTION_213>

Q214: Periodic reviews – would a minimum requirement of undertaking reviews on a half-yearly basis seem reasonable for investment firms engaged in algorithmic trading activity, and if not, what would be an appropriate minimum interval for undertaking such reviews? Should a more prescriptive rule be set as to when more frequent reviews need be taken?

<ESMA_QUESTION_214>

AFME Response

No AFME does not think that there should be a more prescriptive rule – firms will need some flexibility in applying the requirements. In line with other timeframes AFME would strongly note once more that such a periodic review should be carried out on an annual basis.

<ESMA_QUESTION_214>

Q215: Are there any elements that have not been considered and / or need to be further clarified here?

<ESMA_QUESTION_215>

AFME Response

No. Additionally it should be further clarified what 'assessing training and competency' means. It is not practical to require investment firms to assess the training and competency of clients. Firms can be expected to offer training but not assess competency.

FOREIGN EXCHANGE

For FX, the GFXD would like to state that as FX is a global market, operating on a cross jurisdictional basis that DEA participants that reside in different jurisdictions will result in challenges in implementing the DEA obligations under MiFID. The GFXD has continually supported the view that regulatory deliverables should be aligned on a global basis. Such an approach offers regulators the ability to accurately consolidate data across jurisdictional boundaries, allows market participants to transact on a consistent basis and prevents market fragmentation as well as exposing market participants to any undue, increased costs due to jurisdictional specific deliverables.



The GFXD therefore proposes that for FX there is a globally consistent implementation of regulatory obligations concerning Microstructural issues. We believe that, due to the cross border nature of the FX market, market participants should not be disadvantaged by inconsistent application.

<ESMA_QUESTION_215>

Q216: What is your opinion of the elements that the DEA provider should take into account when performing the due diligence assessment? In your opinion, should any elements be added or removed? If so, which?

<ESMA_QUESTION_216>

AFME Response

The nature of the proposed elements is such that DEA Users would become subject to onerous controls than members/participants of the trading venue. In particular, on para 95, Source Code is the intellectual property of its owner, it would not be available to the DEA provider, nor would it be the DEA provider's right to request it and so this sets up an obligation that the DEA provider is unable to fulfill. This means an unlevel playing field is created for DEA Users and members/participants of a trading venue, and many of these checks would be excessive with regard to DEA Users who are in fact authorised firms under MiFID II. Furthermore, training of the DEA Users employees by the DEA Provider seems excessive also.

FOREIGN EXCHANGE

For FX, the GFXD would like to state that as FX is a global market, operating on a cross jurisdictional basis that DEA participants that reside in different jurisdictions will result in challenges in implementing the DEA obligations under MiFID. The GFXD has continually supported the view that regulatory deliverables should be aligned on a global basis. Such an approach offers regulators the ability to accurately consolidate data across jurisdictional boundaries, allows market participants to transact on a consistent basis and prevents market fragmentation as well as exposing market participants to any undue, increased costs due to jurisdictional specific deliverables.

The GFXD therefore proposes that for FX there is a globally consistent implementation of regulatory obligations concerning Microstructural issues. We believe that, due to the cross border nature of the FX market, market participants should not be disadvantaged by inconsistent application.

<ESMA_QUESTION_216>

Q217: Do you agree that for assessing the adequacy of the systems and controls of a prospective DEA user, the DEA provider should use the systems and controls requirements applied by trading venues for members as a benchmark?

<ESMA_QUESTION_217>

AFME Response

Please see our response to question 216 above

FOREIGN EXCHANGE

For FX, the GFXD would like to state that as FX is a global market, operating on a cross jurisdictional basis that DEA participants that reside in different jurisdictions will result in challenges in implementing the DEA obligations under MiFID. The GFXD has continually supported the view that regulatory deliverables should be aligned on a global basis. Such an approach offers regulators the ability to accurately consolidate data across jurisdictional boundaries, allows market participants to transact on a consistent basis and prevents market fragmentation as well as exposing market participants to any undue, increased costs due to jurisdictional specific deliverables.

The GFXD therefore proposes that for FX there is a globally consistent implementation of regulatory obligations concerning Microstructural issues. We believe that, due to the cross border nature of the FX market, market participants should not be disadvantaged by inconsistent application.

<ESMA_QUESTION_217>

Q218: Do you agree that a long term prior relationship (in other areas of service than DEA) between the investment firm and a client facilitates the due diligence process for providing DEA and, thus, additional precautions and diligence are needed when allowing a new client (to whom the investment firm has never provided any other services previously) to use DEA? If yes, to what extent does a long term relationship between the investment firm and a client facilitate the due diligence process of the DEA provider? Please elaborate.

<ESMA_QUESTION_218>

AFME Response

Subject that regardless of length of relationship an investment firm should know-its-clients, AFME observes that a prior long term relationship between an investment firm and a client goes some way to facilitating the due diligence process for providing DEA, but would regard a users regulatory authorisation in Europe or the US, coupled with a good track record, as even more compelling

<ESMA_QUESTION_218>

Q219: Do you agree with the above approach? Please elaborate.

<ESMA_QUESTION_219>

AFME Response

No. AFME notes that at para 100 ESMA must mean the ability to cancel an order, rather than a trade.

AFME considers also that the requirements proposed are generally over prescriptive in light of the benefits they may bring.

Referring to para 105 (i), AFME does not believe it is the responsibility of the DEA Provider to be aware of what the DEA User is permitted to trade down to instrument level, and that the DEA User's regulatory permission and authorisation should suffice.

AFME considers also that the requirement proposed in Para 105 (iii) is overly prescriptive and could result in unintended consequences. DEA Users are unlikely to be motivated to train with



every DEA Provider which could lead to competitive tension as DEA Users concentrated to one or a few providers. Alternatively DEA Providers may be counterproductively incentivised to set training at an inappropriately low level to attract DEA Users. Instead User training should be defined in order that it is standardised, or be set according to competencies such as the possession of regulatory qualification or a training mandate set up within the authorised DEA User.

<ESMA_QUESTION_219>

Q220: Do you agree with the above approach, specifically with regard to the granular identification of DEA user order flow as separate from the firm's other order flow? Please elaborate.

<ESMA_QUESTION_220>

AFME Response

No, AFME is perplexed as to how, para 114 in particular, relates to Article 48 (10) which requires flagging of the algorithms of members/participants of a trading venue only. Under the German HFT Law, regulators there eventually determined this was too complex and impractical to implement.

<ESMA_QUESTION_220>

Q221: Are there any criteria other than those listed above against which clearing firms should be assessing their potential clients?

<ESMA_QUESTION_221>
TYPE YOUR TEXT HERE
<ESMA_QUESTION_221>

Q222: Should clearing firms disclose their criteria (some or all of them) in order to help potential clients to assess their ability to become clients of clearing firms (either publicly or on request from prospective clients)?

<ESMA_QUESTION_222>
TYPE YOUR TEXT HERE
<ESMA_QUESTION_222>

Q223: How often should clearing firms review their clients' ongoing performance against these criteria?

<ESMA_QUESTION_223>
TYPE YOUR TEXT HERE
<ESMA_QUESTION_223>

Q224: Should clearing firms have any arrangement(s) other than position limits and margins to limit their risk exposure to clients (counterparty, liquidity, operational and any other risks)? For example, should clearing firms stress-test clients' positions that could pose material risk to the clearing firms, test their own ability to meet initial margin and variation margin requirements, test their own ability to liquidate their clients' positions in an orderly manner and estimate the cost of the liquidation, test their own credit lines?

<ESMA_QUESTION_224>
TYPE YOUR TEXT HERE
<ESMA_QUESTION_224>



Q225: How regularly should clearing firms monitor their clients' compliance with such limits and margin requirements (e.g. intra-day, overnight) and any other tests, as applicable?

<ESMA_QUESTION_225>
TYPE YOUR TEXT HERE
<ESMA_QUESTION_225>

Q226: Should clearing firms have a real-time view on their clients' positions?

<ESMA_QUESTION_226>
TYPE YOUR TEXT HERE
<ESMA_QUESTION_226>

Q227: How should clearing firms manage their risks in relation to orders from managers on behalf of multiple clients for execution as a block and post-trade allocation to individual accounts for clearing?

<ESMA_QUESTION_227>
TYPE YOUR TEXT HERE
<ESMA_QUESTION_227>

Q228: Which type(s) of automated systems would enable clearing members to monitor their risks (including clients' compliance with limits)? Which criteria should apply to any such automated systems (e.g. should they enable clearing firms to screen clients' orders for compliance with the relevant limits etc.)?

<ESMA_QUESTION_228>
TYPE YOUR TEXT HERE
<ESMA_QUESTION_228>

4.3. Organisational requirements for trading venues (Article 48 MiFID II)

Q229: Do you agree with requiring trading venues to perform due diligence on all types of entities willing to become members/participants of a trading venue which permits algorithmic trading through its systems?

<ESMA_QUESTION_229>

AFME Response

Requirements here should ensure that trading venues perform the appropriate due diligence on all entities applying to become members/participants of a trading venue, regardless of the type of activity in which the member is involved. However, in line with the concerns raised in the response to question 185 above AFME feels that in performing that due diligence, venues should not seek to duplicate the work done by regulators where those participants are regulated and the approach should accordingly be different.

<ESMA_QUESTION_229>



Q230: Do you agree with the list of minimum requirements that in all cases trading venues should assess prior to granting and while maintaining membership? Should the requirements for entities not authorised as credit institutions or not registered as investment firms be more stringent than for those who are qualified as such?

<ESMA_QUESTION_230>

AFME Response

No, see response to question 229 above

<ESMA_QUESTION_230>

Q231: If you agree that non-investment firms and non-credit institutions should be subject to more stringent requirements to become member or participants, which type of additional information should they provide to trading venues?

<ESMA_QUESTION_231>

AFME Response

There is a great value and a correspondingly high bar for entry to the European regulated markets and trading venues; all entities wishing to access these markets as a member/participant should meet similar entry requirements.

<ESMA_QUESTION_231>

Q232: Do you agree with the list of parameters to be monitored in real time by trading venues? Would you add/delete/redefine any of them? In particular, are there any trading models permitting algorithmic trading through their systems for which that list would be inadequate? Please elaborate.

<ESMA_QUESTION_232>

AFME Response

AFME highlights that para 13 (i) imposes on the trading venue an option that has yet even to be decided upon by ESMA (see p233 CP)

<ESMA_QUESTION_232>

Q233: Regarding the periodic review of the systems, is there any element that has not been considered and/or needs to be further clarified in the ESMA Guidelines that should be included?

<ESMA_QUESTION_233>

AFME Response

AFME notes that trading venues should be obligated to monitor the member/participant's connection to the venue and should be obligated to ensure that the venue's own pre-trade risk con-

trols are working. If, for example, a material number of Members were to become disconnected this could potentially create disorderly markets.

<ESMA_QUESTION_233>

Q234: Do you agree with the above approach?

<ESMA_QUESTION_234>

AFME Response

Yes

<ESMA_QUESTION_234>

Q235: Do you think ESMA should determine minimum standards in terms of latency or is it preferable to consider as a benchmark of performance the principle “no order lost, no transaction lost”?

<ESMA_QUESTION_235>

AFME Response

AFME feels that both approaches can be complimentary. There is a level at which latency leads to a disorderly market as firms then cannot manage their risk effectively. However, acknowledging there is tolerance in systems for some increased latency, then a minimum standard of latency could relate to usual performance, deviating only up to a factor of 'X'.

<ESMA_QUESTION_235>

Q236: Do you agree with requiring trading venues to be able to accommodate at least twice the historical peak of messages?

<ESMA_QUESTION_236>

AFME Response

Yes

<ESMA_QUESTION_236>

Q237: Do you agree with the list of abilities that trading venues should have to ensure the resilience of the market?

<ESMA_QUESTION_237>

AFME Response

AFME agrees with the abilities listed in paragraph 31, however we would strongly disagree with giving exchanges the ability to modify live orders. Cancellation of orders is already permissible under many of the cases listed under paragraph 31. However, amending an order should not be permitted



<ESMA_QUESTION_237>

Q238: Do you agree with the publication of the general framework by the trading venues? Where would it be necessary to have more/less granularity?

<ESMA_QUESTION_238>

AFME Response

AFME partially agrees. Although we support throttling as an efficient mechanism to prevent over flooding of exchange trading platforms, this feature should be designed in such a way that it does not present risks to market participants. Currently these controls in place in some markets can present adverse effects to the members of the platform by throttling cancel requests in addition to new orders and order modifications. When the throttling prevents cancellation of orders, it directly impacts the member/participant and their ability to adjust and control their risk exposure, also impairing their ability to exit the market in a controlled fashion. Finally it also could lead to the member/participant not being able to terminate a client, an algo or any connection in accordance with the regulatory obligation to do so in an ordered fashion.

<ESMA_QUESTION_238>

Q239: Which in your opinion is the degree of discretion that trading venues should have when deciding to cancel, vary or correct orders and transactions?

<ESMA_QUESTION_239>

AFME Response

There can be no justification for a venue to have the ability to amend an order therefore the question only applies to cancellation of an order. AFME would seek to make the delineation between the discretion for a trading venue to set its rule book in relation to the cancellation or throttling of orders but its discretion should not go beyond this. Para 31 viii should be deleted

<ESMA_QUESTION_239>

Q240: Do you agree with the above principles for halting or constraining trading?

<ESMA_QUESTION_240>

AFME Response

AFME is comfortable with the principles for halting or constraining trading, and in fact feels that para 34 (vi) on disclosure is a progressive step.

<ESMA_QUESTION_240>

Q241: Do you agree that trading venues should make the operating mode of their trading halts public?

<ESMA_QUESTION_241>

AFME Response



Yes the operating mode should be public

<ESMA_QUESTION_241>

Q242: Should trading venues also make the actual thresholds in place public? In your view, would this publication offer market participants the necessary predictability and certainty, or would it entail risks? Please elaborate.

<ESMA_QUESTION_242>

AFME Response

Yes the limits should be public

<ESMA_QUESTION_242>

Q243: Do you agree with the proposal above?

<ESMA_QUESTION_243>

AFME Response

Yes

<ESMA_QUESTION_243>

Q244: Should trading venues have the ability to impose the process, content and timing of conformance tests? If yes, should they charge for this service separately?

<ESMA_QUESTION_244>

AFME Response

No, trading venues should supply the means to enable investment firms to fulfil their regulatory obligations without prohibitive charging. Conformance testing should be without charge and not represent an opportunity to create a revenue stream.

In line with the purpose and objectives of the regulation trading venues should not be in a position to profit from a requirement which would mean a loss to the wider market participants. Conformance testing should be without charge and not represent an opportunity to create a revenue stream. The ability to impose process, content and timing of conformance testing should be in the remit of the trading venues however larger trading venues may find this easier to implement than smaller trading venues.

<ESMA_QUESTION_244>

Q245: Should alternative means of conformance testing be permitted?

<ESMA_QUESTION_245>

AFME Response



The possibility to test in the live environment with test symbols should be enabled. This would be complementary to conformance testing and would aid controlled roll-out of software.

<ESMA_QUESTION_245>

Q246: Could alternative means of testing substitute testing scenarios provided by trading venues to avoid disorderly trading conditions? Do you consider that a certificate from an external IT audit would be also sufficient for these purposes?

<ESMA_QUESTION_246>

AFME Response

As noted in our response to question 193, the definition of ‘disorderly trading conditions’ is not clear and is difficult to apply without certain parameters to indicate at what stage a market would be under such ‘disorderly trading conditions’ and how certain events such as ECB announcement causing a shift in market activity would fall into this definition. Some trading venues do not provide testing systems and having an external IT audit would once more place the opportunity to make a profit from a regulatory requirements in the scope of external market participants. Should any such external IT audit be considered as an option we would suggest that further information is provided as to who would monitor such external IT audits and who would be responsible for ensuring that the audit is carried out sufficiently and in line with other requirements.

As per response to question 246 above it is extremely difficult to create test environments that are realistic. It may be more practical to test in a simulated environment provide by a third party whose interface behaves in the same way as the trading venue's.

FOREIGN EXCHANGE

For FX, the GFXD would like to state that as FX is a global market, operating on a cross jurisdictional basis that any testing obligations that unfairly disadvantage firms residing in the EU should be carefully validated especially when these are applied in cross-jurisdictional, global markets like FX. We believe that it would be impractical, given the large number of technology solutions deployed within the market to expect an external IT resource to be able to audit and sufficiently test such scenarios.

The GFXD has continually supported the view that regulatory deliverables should be aligned on a global basis. Such an approach offers regulators the ability to accurately consolidate data across jurisdictional boundaries, allows market participants to transact on a consistent basis and prevents market fragmentation as well as exposing market participants to any undue, increased costs due to jurisdictional specific deliverables.

The GFXD therefore proposes that for FX there is a globally consistent implementation of regulatory obligations concerning Microstructural issues. We believe that, due to the cross border nature of the FX market, market participants should not be disadvantaged by inconsistent application.

<ESMA_QUESTION_246>

Q247: What are the minimum capabilities that testing environments should meet to avoid disorderly trading conditions?

<ESMA_QUESTION_247>



AFME Response

Please see above and question 193 for views and comments in relation to ‘disorderly trading conditions’. We do not feel we can add anything further until clarification can be provided on this definition.

FOREIGN EXCHANGE

For FX, the GFXD would like to state that as FX is a global market, operating on a cross jurisdictional basis that any testing obligations that unfairly disadvantage firms residing in the EU should be carefully validated especially when these are applied in cross-jurisdictional, global markets like FX. The GFXD has continually supported the view that regulatory deliverables should be aligned on a global basis. Such an approach offers regulators the ability to accurately consolidate data across jurisdictional boundaries, allows market participants to transact on a consistent basis and prevents market fragmentation as well as exposing market participants to any undue, increased costs due to jurisdictional specific deliverables.

The GFXD therefore proposes that for FX there is a globally consistent implementation of regulatory obligations concerning Microstructural issues. We believe that, due to the cross border nature of the FX market, market participants should not be disadvantaged by inconsistent application.

<ESMA_QUESTION_247>

Q248: Do you agree with the proposed approach?

<ESMA_QUESTION_248>

AFME Response

No. AFME believes the controls listed above are consistent with those used today; however, we have strong reservations with points 48 (iii) order value and 48 (viii) market impact assessment.

48. (iii) – order value. Order value is simply the order price (i) multiplied by the order size (ii). Required order value in conjunction with (i) and (ii) is duplicative and unnecessary.

48. (viii) – market impact assessment. To be able to determine the market impact of an order it would be necessary for the system entering the order to know the entire order book at any time including liquidity not currently represented by the Trading Venue, be able to forecast order-book impact (including synthetic matching) according to the Trading Venue’s matching rules, and predict how other market participants will react to a new order entering the order book. In addition to being technologically in practice this, fundamentally, is not feasible.

<ESMA_QUESTION_248>

Q249: In particular, should trading venues require any other pre-trade controls?

<ESMA_QUESTION_249>

AFME Response

No. However, although we agree that there should be a standard level of controls for trading venues, it is important to note that different trading venues will have different capabilities e.g.



smaller vs larger trading venues. In addition to the above however it would be important to understand on who the onus lies to make sure that the pre trade controls are being carried out and how the results of any pre trade controls would be communicated to trading venues' participants.

<ESMA_QUESTION_249>

Q250: Do you agree that for the purposes of Article 48(5) the relevant market in terms of liquidity should be determined according to the approach described above? If, not, please state your reasons.

<ESMA_QUESTION_250>

AFME Response

From an equities perspective AFME would highlight that there can be more than one relevant market which will be the case where any market has a material market share of more than 5%

<ESMA_QUESTION_250>

Q251: Are there any other markets that should be considered material in terms of liquidity for a particular instrument? Please elaborate.

<ESMA_QUESTION_251>

AFME Response

See response to question 250 above.

<ESMA_QUESTION_251>

Q252: Which of the above mentioned approaches is the most adequate to fulfil the goals of Article 48? Please elaborate

<ESMA_QUESTION_252>

AFME Response

AFME prefers Option A. Option B sets up a conflict of interests and creates confidentiality issues

Although the importance of provisions and monitoring of DEA is acknowledged it is felt that investment firms should continue to manage their own limits and have the ability to monitor it from a much more granular level than trading venues may be able to. It would be a big ask for trading venues as it would also thus become the responsibility of the trading venues to monitor and identify which may become problematic. In terms of monitoring it would appear to add a layer of granularity which seems unnecessary if the same level of granularity is already explored at investment firms.

<ESMA_QUESTION_252>

Q253: Do you envisage any other approach to this matter?



<ESMA_QUESTION_253>

AFME Response

See response to question 252 above.

<ESMA_QUESTION_253>

Q254: Do you agree with the list of elements that should be published by trading venues to permit the provision of DEA to its members or participants?

<ESMA_QUESTION_254>

TYPE YOUR TEXT HERE

<ESMA_QUESTION_254>

Q255: Do you agree with the list of systems and effective controls that at least DEA providers should have in place?

<ESMA_QUESTION_255>

AFME Response

Different risk controls are appropriate at different points in the trade lifecycle and risk controls should not be unnecessarily duplicated at the client, investment firm and trading venue levels. It is not the role of the trading venue to assess and monitor the underlying client. The trading venue is responsible for its members and the DEA Provider is responsible for its clients.

<ESMA_QUESTION_255>

Q256: Do you consider it is necessary to clarify anything in relation to the description of the responsibility regime?

<ESMA_QUESTION_256>

TYPE YOUR TEXT HERE

<ESMA_QUESTION_256>

Q257: Do you consider necessary for trading venues to have any other additional power with respect of the provision of DEA?

<ESMA_QUESTION_257>

AFME Response

No, in fact AFME notes that these provisions do not necessarily take account of the ESMA view at section 4.4, para 12 of the DP that such indirect participants have not and should be forced into a direct contractual relationship with the trading venue

From a fixed income perspective we would also wish to make the following comments. In relation to point (2) regarding the ability to stop order we would seek further information and clarification as to the parameters which would warrant this to be carried out by a trading venue including on what basis a trading venue could stop orders transmitting.

Suspending and withdrawing DEA (point 3) to clients of investment firms would also need further clarification as to the indicators which would warrant such a step. It is important to know how the information that a client is being suspended or withdrawn would be communicated to the investment firm (who hold the relationship with the client) and aligning the transaction chain to be aware which part of the chain might be causing concerns to warrant any form of suspension/withdrawal. Should there not be a clear process for notification, a client could be unaware that they have been suspended/withdrawn and continue trading. We would also like clarification as to the outcome of liability should any suspension/withdrawal is carried out incorrectly and the timeframe such a mistake would take to rectify.

We have no additional comments in relation to point (4) as this is already being carried out.

In relation to point (5) we would seek further details in relation to the 'DEA legal framework' and how this would work in practice. For example it is not clear whether the implication here is to review each execution agreement between an investment firm and a client across all firms/members of the trading venues and what they would then envisage to do with the agreements and what actions would be taken.

<ESMA_QUESTION_257>

4.4. Market making strategies, market making agreements and market making schemes

Q258: Do you agree with the previous assessment? If not, please elaborate.

<ESMA_QUESTION_258>

AFME Response

No. AFME would encourage ESMA to be mindful of the difference in Art 17 (3) and Article 48 (2) when drafting proposed regulatory technical standards as they relate to market making under Articles 17 and 48. Article 17 (3) notes that where an investment firm is using an algorithmic trading strategy to pursue a market making strategy, a written agreement will be required between the firm and the respective trading venues (an RM, MTF or OTF). Article 48 (2) requires a written agreement where a market making strategy is pursued on an RM whether done through an algorithmic trading strategy or otherwise.

FX For FX, the GFXD would like to state that as FX is a global market, operating on a cross jurisdictional basis that any market making obligations imposed on an investment firms that reside within the EU will unfairly disadvantage such investment firms, especially when transacting in global markets like the FX market. The GFXD has continually supported the view that regulatory deliverables should be aligned on a global basis. Such an approach offers regulators the ability to accurately consolidate data across jurisdictional boundaries, allows market participants to transact on a consistent basis and prevents market fragmentation as well as exposing market participants to any undue, increased costs due to jurisdictional specific deliverables.

The GFXD therefore proposes that for FX there is a globally consistent implementation of regulatory obligations concerning Microstructural issues. We believe that, due to the cross border nature of the FX market, market participants should not be disadvantaged by inconsistent application.



Finally the GFXD agrees that in the context of ‘market making’ and ‘market making strategy’ requirements are only applicable to instruments in scope that are defined in MiFID annex C4.

<ESMA_QUESTION_258>

Q259: Do you agree with the preliminary assessments above? What practical consequences would it have if firms would also be captured by Article 17(4) MiFID II when posting only one-way quotes, but doing so in different trading venues on different sides of the order book (i.e. posting buy quotes in venue A and sell quotes in venue B for the same instrument)?

<ESMA_QUESTION_259>

AFME Response

No. AFME agrees with ESMA on its assertion in para 17 that a market making strategy is one where an investment firm operates firm, simultaneous two-way quote in at least one financial instrument on a single venue, therefore two-way quotes applying to single or multiple venues. This is not a two-way quote spread over two venues (one side on each venue) as may be misinterpreted in Article 17 (4) by use of "across venues".

Therefore idea of 'one way quotes' is not one which is within the remit of Art 17. Additionally consideration should be given, particularly from a fixed income viewpoint, of variances in liquidity for different financial instruments.

<ESMA_QUESTION_259>

Q260: For how long should the performance of a certain strategy be monitored to determine whether it meets the requirements of Article 17(4) of MiFID II?

<ESMA_QUESTION_260>

AFME Response

From an equities perspective 3 months would be agreeable.

From a fixed income perspective AFME believes that the timeframe in which a strategy should be monitored to determine whether it meets the requirements of Article 17 should be a continuous timeframe as well as taking into account that for fixed income liquidity in the market may prevent trading for prolonged periods of time. There may be a ‘break’ in trading a particular instrument for some days and then it is traded again. In this instance it is not clear whether this would be taken into account when determining whether a strategy would be considered to be one of market making.

<ESMA_QUESTION_260>

Q261: What percentage of the observation period should a strategy meet with regard to the requirements of Article 17(4) of MiFID II so as to consider that it should be captured by the obligation to enter into a market making agreement?

<ESMA_QUESTION_261>

AFME Response



From an equities perspective 80% would be agreeable.

From a fixed income perspective AFME believes that it is more complex to provide a definitive observation period and would wish ESMA to consider the notion of liquidity when looking at this concept for different asset classes (also within the fixed income asset classes themselves).

<ESMA_QUESTION_261>

Q262: Do you agree with the above assessment?

<ESMA_QUESTION_262>

AFME Response

Yes

<ESMA_QUESTION_262>

Q263: Do you agree with this interpretation?

<ESMA_QUESTION_263>

AFME Response

Provided this remains within the remit of Article 17 then AFME agrees with ESMA's interpretation that 'posting firm quotes' means a quote is firm as long as it is executable, i.e. that it can be matched against an opposite order.

<ESMA_QUESTION_263>

Q264: Do you agree with the above assessment? If not, please elaborate.

<ESMA_QUESTION_264>

AFME Response

Please see response to question 259 regarding one way quotes.

<ESMA_QUESTION_264>

Q265: Do you agree with the above interpretation?

<ESMA_QUESTION_265>

AFME Response

Yes

<ESMA_QUESTION_265>

Q266: Do you agree with the above proposal?



<ESMA_QUESTION_266>

AFME Response

AFME does not fully understand the intention of this proposal and would welcome further dialogue

<ESMA_QUESTION_266>

Q267: Do you agree with the above proposal?

<ESMA_QUESTION_267>

AFME Response

Yes

<ESMA_QUESTION_267>

Q268: Do you agree with the approach described (non-exhaustive list of quoting parameters)?

<ESMA_QUESTION_268>

AFME Response

From an equities perspective AFME agrees, however, particularly for fixed income, some issuers will consider your performance and the agreement with an investment firm may have with a platform. It should be noted that this investment firm should not be tied to a narrow obligation due to this agreement between venue and firm. Venues should take into account that market makers will perform their duties on multiple platforms.

In the case of primary dealer agreements we question whether these could be seen as market making and primary dealers must therefore apply to a venue and commit to provide liquidity all day every day which is not practicable. The continuous liquidity provision to numerous venues places much more responsibility on investment firms.

<ESMA_QUESTION_268>

Q269: What should be the parameters to assess whether the market making schemes under Article 48 of MiFID II have effectively contributed to more orderly markets?

<ESMA_QUESTION_269>

AFME Response

AFME believes this would be extremely challenging given all the factors that need to be taken into account when trying to assess what makes a more orderly market

<ESMA_QUESTION_269>

Q270: Do you agree with the list of requirements set out above? Is there any requirement that should be added / removed and if so why?

<ESMA_QUESTION_270>

AFME Response

On para 34.ix we respectfully request some clarification of the term “retreat from the market” in the ESMA text the under sub paragraph ix on page 267 that the investment firm “should commit to settle, close or transfer all open positions to another member in the case from retreating from the market”. We are unclear as to what circumstance this is intended to address. An investment firm surely ought not be under an obligation to transfer its entire book of trades to another member simply because it ceases to be willing to be a market maker. This might be a huge book of business with substantially offsetting positions (including many positions not executed on the relevant venue or any venue) that it intends to run to maturity. There should be no obligation to sell these positions provided the investment firm continues to service all operational and margining requirements in respect of the portfolio. If “retreat” from the market envisages the investment firm ceasing to have the ability or desire to perform these obligations on an ongoing basis then we agree that the portfolio ought be transferred – but this ought not be a provision of the market making agreement with a venue but, for cleared instruments, would be more suitably a provision of its clearing agreements.

Para 34.vii seems superfluous given it is already covered under remuneration schemes and is in place as good market practise. Para 34.viii would be better redrafted as "have robust post trade systems in place".

<ESMA_QUESTION_270>

Q271: Please provide views, with reasons, on what would be an adequate presence of market making strategies during trading hours?

<ESMA_QUESTION_271>

AFME Response

It is AFME's view that the adequate presence of market making strategies in equities has naturally and appropriately evolved to a level of 80% and AFME believes that this remains the appropriate level of presence going forward for market making strategies in equities during the normal continuous trading hours. From a fixed income perspective however we would like to suggest that this percentage could possibly has been averaged over a considerable period of time e.g. One month.

FOREIGN EXCHANGE:

For FX, the GFXD would like to reference that the FX market operates globally, on a cross jurisdictional basis, is open 24 hours a day, for 5.5 days of the week with regular trading occurring continuously during this period. Trading hours can also vary by global platform or individual instances of platforms in the regions serving the needs for the local market. Due to the extensive and varied nature of the trading hours and regions covered, any market making presence requirements should be determined in the accordance with the business operating day of the platform.



<ESMA_QUESTION_271>

Q272: Do you consider that the average presence time under a market making strategy should be the same as the presence time required under a market making agreement ?

<ESMA_QUESTION_272>

AFME Response

AFME does not fully understand this question and would welcome further dialogue.

<ESMA_QUESTION_272>

Q273: Should the presence of market making strategies during trading hours be the same across instruments and trading models? If you think it should not, please indicate how this requirement should be specified by different products or market models?

<ESMA_QUESTION_273>

AFME Response

AFME believes for cash equities the presence of market making strategies can be the same for all instruments and trading models during normal continuous trading hours. Consideration should be given, particularly from a fixed income viewpoint, of variances in liquidity for different financial instruments. It would be very difficult to define in an absolute sense what a reasonable bar should be for fixed income.

<ESMA_QUESTION_273>

Q274: Article 48(3) of MiFID II states that the market making agreement should reflect “where applicable any other obligation arising from participation in the scheme”. What in your opinion are the additional areas that that agreement should cover?

<ESMA_QUESTION_274>

AFME Response

Nothing to add

<ESMA_QUESTION_274>

Q275: Do you disagree with any of the events that would qualify as ‘exceptional circumstances’? Please elaborate.

<ESMA_QUESTION_275>

AFME Response

Yes. AFME believes that although the listed examples by ESMA are fair, it should be considered that these ‘exceptional circumstances’ should apply to specific market conditions rather than risk assessment issues. Market volatility and movement should be a clear indication of an ‘excep-



tional circumstance' should this change in 'orderly functioning of the market' be substantial enough to cause liquidity issues as well as disorderly market conditions.

<ESMA_QUESTION_275>

Q276: Are there any additional 'exceptional circumstances' (e.g. reporting events or new fundamental information becoming available) that should be considered by ESMA? Please elaborate.

<ESMA_QUESTION_276>

AFME Response

Exceptional circumstances must also take into consideration market events as well as natural disasters which should also be considered. The shifts of capital costs as well as sudden increases in margin requirements for one reason or another could also mean that an investment firm may no longer be able to provide market making. AFME also notes agreement with para 42 of ES-MAs proposal noting that 'In principle new information (e.g. reporting events or fundamental information) becomes available, it may give rise to significant and unexpected price movements, leading to operators of a market making strategy to suspect that the prices (buy and sell) it is posting no longer reflect the fundamental supply and demand characteristics in relation to the instrument it is trading (i.e. incompleteness of information between the market maker and other market making participants, which allow these market participants to exploit the market makers outstanding quotes).

<ESMA_QUESTION_276>

Q277: What type of events might be considered under the definition of political and macroeconomic issues?

<ESMA_QUESTION_277>

AFME Response

The following types of elements should be included however AFME believes that this should be a non-exhaustive list. Examples to be included are:

Outbreak of War

Sovereign default

Act of Terrorism

Social/Military unrest

Failure of major financial institution

<ESMA_QUESTION_277>



Q278: What is an appropriate timeframe for determining whether exceptional circumstances no longer apply?

<ESMA_QUESTION_278>

AFME Response

This depends on the circumstances and should be based on a case by case basis and may range from a number of seconds to a numbers of days

<ESMA_QUESTION_278>

Q279: What would be an appropriate procedure to restart normal trading activities (e.g. auction periods, notifications, timeframe)?

<ESMA_QUESTION_279>

AFME Response

AFME observes there may be some confusion in this section of the DP around the cessation of market making and closure of the market. A Market maker would notify the trading venue and simply start quoting.

Particularly for fixed income AFME seeks clarification and parameters as to the phrase 'normal trading conditions'. For fixed income this can vary in terms of liquidity and specific instruments. The restart should be the start of any normal day but there needs to be some form of notice period and time which needs to be as long if not longer than how long it would take them to respond.

Please also refer to our response in relation to question 190 and 'disorderly trading conditions'.

<ESMA_QUESTION_279>

Q280: Do you agree with this approach? If not, please elaborate.

<ESMA_QUESTION_280>

AFME Response

No. AFME seeks clarification and further dialogue upon para 43 (i) and (iii). Furthermore, AFME seeks clear and detailed wording as to the contractual arrangement, rules and reasoning by which venues are able to delete any transactions/orders. Additionally it must be indicated within what timeframe a venue will inform the investment firm that an action, such as deletion of a transaction/order, has been taken by a venue.

<ESMA_QUESTION_280>

Q281: Would further clarification be necessary regarding what is “fair and non-discriminatory”? In particular, are there any cases of discriminatory access that should be specifically addressed?

<ESMA_QUESTION_281>



AFME Response

Venues should not set an upper limit in terms of the number of market makers they allow other than for technological/capacity reasons - i.e. There needs to be fair, reasonable and non-discriminatory access

<ESMA_QUESTION_281>

Q282: Would it be acceptable setting out any type of technological or informational advantages for participants in market making schemes for liquid instruments? If yes, please elaborate.

<ESMA_QUESTION_282>

AFME Response

AFME feels this is dependent on what these technological advantages and informational advantages should incorporate. It should be possible to determine market making schemes without excessive regulatory oversight. We would seek for as much flexibility here as possible.

It is going to lead different investment firms to end up entering into different agreements with different platforms and we would seek further information as to how this can best be made practicable.

We would seek clarification as to who is overseeing the venues to ensure they are complying and under what parameters as well as ensuring there is no arbitrage?

<ESMA_QUESTION_282>

Q283: In which cases should a market operator be entitled to close the number of firms taking part in a market making scheme?

<ESMA_QUESTION_283>

AFME Response

As per response to question 281 above limiting firms in taking part in market making schemes would not be fair and non-discriminatory. Market making schemes by their nature should be open ended.

<ESMA_QUESTION_283>

Q284: Do you agree that the market making requirements in Articles 17 and 48 of MiFID II are mostly relevant for liquid instruments? If not, please elaborate how you would apply the requirements in Articles 17 and 48 of MiFID II on market making schemes/agreements/strategies to illiquid instruments.

<ESMA_QUESTION_284>

AFME Response



There seems to be some confusion in the drafting of this section of the DP insofar as a market making scheme seems suggested to be separate and distinct to an arrangement that leads to a market making agreement - see article 48 (2) & (3)

<ESMA_QUESTION_284>

Q285: Would you support any other assessment of liquidity different to the one under Article 2(1)(17) of MiFIR? Please elaborate.

<ESMA_QUESTION_285>

AFME Response

Please see our response to question 284 above

<ESMA_QUESTION_285>

Q286: What should be deemed as a sufficient number of investment firms participating in a market making agreement?

<ESMA_QUESTION_286>

AFME Response

Please see our response to questions 281 and 284 above

<ESMA_QUESTION_286>

Q287: What would be an appropriate market share for those firms participating in a market making agreement?

<ESMA_QUESTION_287>

AFME Response

Please see our response to question 284 above

<ESMA_QUESTION_287>

Q288: Do you agree that market making schemes are not required when trading in the market via a market making agreement exceeds this market share?

<ESMA_QUESTION_288>

AFME Response

Please see our response to question 284 above

<ESMA_QUESTION_288>



Q289: In which cases should a market operator be entitled to close the number of firms taking part in a market making scheme?

<ESMA_QUESTION_289>

AFME Response

Please see our response to question 284 above

<ESMA_QUESTION_289>



4.5. Order-to-transaction ratio (Article 48 of MiFID II)

Q290: Do you agree with the types of messages to be taken into account by any OTR?

<ESMA_QUESTION_290>

AFME Response

AFME agrees with ESMA's approach that "all messages related to an order (submission, price and volume modifications and deletions" should be taken into account under any OTR regime. However ESMA should clarify only messages an investment firm can actively control will be included in any calculation.

The purpose of introducing an Order-to-transaction (OTR) ratio as required by Article 48(6) MiFID II is to ensure orderly trading conditions on trading venues by controlling the number of orders members may send to the matching engine of a trading venue in order to ensure the capacity of the latter is not exceeded. Because the objective is to restrict the behaviour of members, any OTR calculation should only include messages the member can actively control. Therefore, acknowledgment and confirmation messages relating to an order and sent by the trading venue to the member should be excluded.

Furthermore, AFME believes special attention should be given to the position of market makers having continuous quoting obligations (CQO) as required under Article 17(3) MiFID II or under any legally binding market-making agreement they have entered into with a trading venue. While market makers actively monitor and control the number of messages they send to the market, in certain circumstances they may be prohibited from reducing the number of messages to comply with the mandatory OTR regime because doing so would be contrary to their CQO. Therefore, bearing in mind this possibility of conflicting obligations, we strongly emphasize the need to provide an exemption for market makers from the application of the mandatory OTR regime as ESMA has suggested (par. 20 (ii), p. 278). For additional arguments on the need to have an exemption in the mandatory OTR regime for market makers, we refer you to the answers to question 304.

<ESMA_QUESTION_290>

Q291: What is your view in taking into account the value and/or volume of orders in the OTRs calculations? Please provide:

<ESMA_QUESTION_291>

AFME Response

If the OTRs are adjusted to include the relative weight of the orders this will penalize flows that use 'outsized aggressive orders'. There are many reasons to outsize aggressive orders:

1) There can be more quantity at a price level than is currently displayed. This could be executions from hidden order internally or on the exchange.



2) Many algorithms have ‘Would’ or ‘Would If I Could’ functionality. This states the client is happy to get some or all of the order done if a current price is available in the market. If this instruction is in place a very large qty is sent as an aggressive when only a small amount is displayed.

The reason the algorithms do this is because an IOC order will not display the quantity to the market unless it gets an execution. It is therefore safe to IOC large quantities.

This solution would also be heavily impacted by orders trading in the auctions that are limited away from the final close price. These are often a large portion of VWAP and other such orders. If the client specifies a low limit on their order, it must be submitted to the closing auction at this price. Given the large notional value that goes through the auctions a share or notional weighted average fill rate would be brought down by these.

If a notional weighted OTR was used it should exclude immediate execution orders i.e. IOC, FOK etc. It should also exclude auction orders.

<ESMA_QUESTION_291>

Q292: Should any other additional elements be taken into account to calibrate OTRs? If yes, please provide an explanation of why these variables are important.

<ESMA_QUESTION_292>

AFME Response

No

<ESMA_QUESTION_292>

Q293: Do you agree with the proposed scope of the OTR regime under MiFID II (liquid cash instruments traded on electronic trading systems)?

<ESMA_QUESTION_293>

AFME Response

Members would seek further clarification as to whether this also includes MTFs/OTFs or only RMs? AFME agrees with the scope of the OTR regime proposed by ESMA

<ESMA_QUESTION_293>

Q294: Do you consider that financial instruments which reference a cash instrument(s) as underlying could be excluded from the scope of the OTR regime?

<ESMA_QUESTION_294>

AFME Response

AFME agrees with the proposed approach that instruments with underlying reference cash instruments be out of scope of the mandatory OTR regime with particular reference to derivatives as suggested by ESMA but noting ETFs should be treated in the same way. AFME feels that the



trading venue should be allowed discretion regarding the appropriateness of the OTR in relation to the specific market or instrument.

<ESMA_QUESTION_294>

Q295: Would you make any distinction between instruments which have a single instrument as underlying and those that have as underlying a basket of instruments? Please elaborate.

<ESMA_QUESTION_295>

AFME Response

Yes, AFME would make a distinction between instruments which have a single instrument as underlying and those that have as underlying a basket of instruments, particularly with regard to ETFs and would reiterate comments in response to question 294 above

<ESMA_QUESTION_295>

Q296: Do you agree with considering within the scope of a future OTR regime only trading venues which have been operational for a sufficient period in the market?

<ESMA_QUESTION_296>

AFME Response

AFME agrees with ESMA's suggested approach of only including in the scope of the mandatory OTR regime trading venues that are sufficiently established in the market. AFME believes that any given period of time should expire upon the trading venue reaching a EU market share of 5% or more measured by value of turnover.

<ESMA_QUESTION_296>

Q297: If yes, what would be the sufficient period for these purposes?

<ESMA_QUESTION_297>

AFME Response

Please see response to question 296 above

<ESMA_QUESTION_297>

Q298: What is your view regarding an activity floor under which the OTR regime would not apply and where could this floor be established?

<ESMA_QUESTION_298>

AFME Response

AFME believes ESMA should allow trading venues to apply a floor under which the OTR regime would not apply.

<ESMA_QUESTION_298>



Q299: Do you agree with the proposal above as regards the method of determining the OTR threshold?

<ESMA_QUESTION_299>

AFME Response

AFME believes that the determination of the OTR should be left to trading venues. The purpose of introducing OTR is to ensure orderly trading conditions on trading venues by controlling the number of orders members may send to the matching engine, thereby ensuring system capacity is not exceeded. The trading venue is best positioned to assess what level of messaging their systems can handle.

AFME believes establishing a multiplier (x) based on the average OTR observed on a trading venue for a group of instruments is a 'one-size-fits-all' approach that does not sufficiently take into account differences between instruments and individual products in terms of trading volume, volatility or frequency of quote-updates.

Therefore AFME believes ESMA should develop an alternative approach where it formulates key principles that a mandatory OTR must comply with, but leaves it to trading venues to determine the OTR per instrument and per product based on what their systems can safely accommodate.

Probable redrafting required

<ESMA_QUESTION_299>

Q300: In particular, do you consider the approach to base the OTR regime on the 'average observed OTR of a venue' appropriate in all circumstances? If not, please elaborate.

<ESMA_QUESTION_300>

AFME Response

Please response to question 299 above

<ESMA_QUESTION_300>

Q301: Do you believe the multiplier x should be capped at the highest member's OTR observed in the preceding period?

<ESMA_QUESTION_301>

AFME Response

Please response to question 299 above

<ESMA_QUESTION_301>

Q302: In particular, what would be in your opinion an adequate multiplier x? Does this multiplier have to be adapted according to the (group of) instrument(s) traded? If yes, please specify in your response the financial instruments/market segments you refer to.

<ESMA_QUESTION_302>



AFME Response

Please response to question 299 above

<ESMA_QUESTION_302>

Q303: What is your view with respect to the time intervals/frequency for the assessment and review of the OTR threshold (annually, twice a year, other)?

<ESMA_QUESTION_303>

AFME Response

Please response to question 299 above

<ESMA_QUESTION_303>

Q304: What are your views in this regard? Please explain.

<ESMA_QUESTION_304>

AFME Response

AFME believes that market makers should be completely exempt from the OTR regime. Therefore AFME supports the option (ii) of maintaining the current practice in granting an exemption for market makers and other liquidity providers.

A market maker provides a service to the market in the form of additional liquidity by continuously sending orders into the market to update his prices and provide two sided quotes. He cannot control how many of these orders will be matched by other members of the trading venue and will result in actual transactions. Therefore, he can control his level of messaging but not the OTR this level messaging will generate.

Applying a mandatory OTR regime to market makers may lead to a situation where complying with a CQO may lead to a violation of the OTR (or vice versa). This would create potentially conflicting obligations for market makers, which we do not believe is the intent of the legislator. We also believe the obligation to provide liquidity should prevail over the obligation to comply with a mandatory OTR regime, as long as this does not put undue stress on the systems of a trading venue.

<ESMA_QUESTION_304>

4.6. Co-location (Article 48(8) of MiFID II)

Q305: What factors should ESMA be considering in ensuring that co-location services are provided in a ‘transparent’, ‘fair’ and ‘non-discriminatory’ manner?

<ESMA_QUESTION_305>

AFME Response



AFME agrees that co-location services should be provided in a transparent, fair and non-discriminatory manner in line with AFME's own pro-competition standpoint. To ensure transparent, fair and non-discriminatory co-location services offered by trading venues, ESMA should consider the following factors:

a. Non-discriminatory pricing:

In order to ensure co-location services are transparent, fair and non-discriminatory trading venues must publish or make available on demand their commercial policy including the list of prices as well as the objective conditions for accessing the co-location services. In evaluating reasonableness, trading venues should offer services

(i) with rates that are not so prohibitive that only a small percentage of members who might benefit could afford them and

(ii) that are priced comparably to similar services offered elsewhere in the market and do not unreasonably benefit from a trading venue's unilateral control over their own data, facilities, etc, and

(iii) services should be available on a standalone basis not as bundled packages that may discriminate between market participants

b. Transparency of data centre agreements:

Trading venues should make available clear documentation about their products and services with all relevant information including pricing. Under no circumstances should trading venues be allowed to inform only certain market participants of the existence of certain services. The fees charged to market participants must be uniform between market participants using the same services and should not discriminate against different classes of market participants – they should offer their services to all qualified participants on identical and transparent terms. Allocation and availability of data centres should be fair, as should a markets participant's usage there of, the trading venue should not be able to apply restrictions on usage.

<ESMA_QUESTION_305>

4.7. Fee structures (Article 48 (9) of MiFID II)

Q306: Do you agree with the approach described above?

<ESMA_QUESTION_306>

AFME Response

AFME welcomes transparency on fee structures.

<ESMA_QUESTION_306>

Q307: Can you identify any practice that would need regulatory action in terms of transparency or predictability of trading fees?

<ESMA_QUESTION_307>
TYPE YOUR TEXT HERE
<ESMA_QUESTION_307>

Q308: Can you identify any specific difficulties in obtaining adequate information in relation to fees and rebates that would need regulatory action?

<ESMA_QUESTION_308>

AFME Response

No, AFME believes such any such difficulties are overcome by the requirement to publish

<ESMA_QUESTION_308>

Q309: Can you identify cases of discriminatory access that would need regulatory action?

<ESMA_QUESTION_309>

AFME Response

Historically, there have been cases of trading venues restricting faster access to vendors.

<ESMA_QUESTION_309>

Q310: Are there other incentives and disincentives that should be considered?

<ESMA_QUESTION_310>

AFME Response

No

<ESMA_QUESTION_310>

Q311: Do any of the parameters referred to above contribute to increasing the probability of trading behaviour that may lead to disorderly and unfair trading conditions?

<ESMA_QUESTION_311>

AFME Response

AFME thinks that fee structure is not the right parameter to look at to avoid disorderly trading.

<ESMA_QUESTION_311>

Q312: When designing a fee structure, is there any structure that would foster a trading behaviour leading to disorderly trading conditions? Please elaborate.

<ESMA_QUESTION_312>



AFME Response

Please see response to question 317 below

<ESMA_QUESTION_312>

Q313: Do you agree that any fee structure where, upon reaching a certain threshold of trading by a trader, a discount is applied on all his trades (including those already done) as opposed to just the marginal trade executed subsequent to reaching the threshold should be banned?

<ESMA_QUESTION_313>

AFME Response

AFME is supportive of ESMA's view on the removal of cliff structures. AFME would also request that ESMA remain alert to potentially related practices such as offering participants heavily discounted or free market data where they agree to trade solely on the operator's trading venue.

<ESMA_QUESTION_313>

Q314: Can you identify any potential risks from charging differently the submission of orders to the successive trading phases?

<ESMA_QUESTION_314>

AFME Response

Please see response to question 317 below

<ESMA_QUESTION_314>

Q315: Are there any other types of fee structures, including execution fees, ancillary fees and any rebates, that may distort competition by providing certain market participants with more favourable trading conditions than their competitors or pose a risk to orderly trading and that should be considered here?

<ESMA_QUESTION_315>

AFME Response

Please see response to question 317 below

<ESMA_QUESTION_315>

Q316: Are there any discount structures which might lead to a situation where the trading cost is borne disproportionately by certain trading participants?

<ESMA_QUESTION_316>

AFME Response



In theory, cliff fee structures (i.e. rebates after a certain trading volume threshold) could lead to such a scenario, but we are not aware that such a cliff structure exists in practice

Otherwise please see response to question 317 below

<ESMA_QUESTION_316>

Q317: For trading venues charging different trading fees for participation in different trading phases (i.e. different fees for opening and closing auctions versus continuous trading period), might this lead to disorderly trading and if so, under which circumstances would such conditions occur?

<ESMA_QUESTION_317>

AFME Response

It is not necessarily the case that charging different fees for different trading phases will lead to disorderly markets. However, AFME notes that there may be incidences where a trading venue may be able to use its leverage in trading phases where it has the monopoly, exerting pricing power, which would lead to an anti-competitive market. This may also incentivise higher risk behaviour of market participants seeking cheaper prices elsewhere during that trading phase.

<ESMA_QUESTION_317>

Q318: Should conformance testing be charged?

<ESMA_QUESTION_318>

AFME Response

No, trading venues should not charge for technical conformance testing, which is a mandatory step to confirm a system's functionality while interacting with a trading venue. This process is often guided by a script of tests provided by the trading venue and is performed in a trading venue-provided test environment to simulate the production trading environment.

<ESMA_QUESTION_318>

Q319: Should testing of algorithms in relation to the creation or contribution of disorderly markets be charged?

<ESMA_QUESTION_319>

AFME Response

No

<ESMA_QUESTION_319>

Q320: Do you envisage any scenario where charging for conformance testing and/or testing in relation to disorderly trading conditions might discourage firms from investing sufficiently in testing their algorithms?



<ESMA_QUESTION_320>

AFME Response

Yes

<ESMA_QUESTION_320>

Q321: Do you agree with the approach described above?

<ESMA_QUESTION_321>

AFME Response

No

<ESMA_QUESTION_321>

Q322: How could the principles described above be further clarified?

<ESMA_QUESTION_322>

AFME Response

AFME believes that a trading venue should not be obliged per se to have a market making scheme in place. On Para 30.1 if an instrument is liquid, market making is not strictly necessary. Para 30.3 should be left to the venue. We do not agree with the last sentence here and refer to our previous answer on 80% availability during reasonable liquid times.

<ESMA_QUESTION_322>

Q323: Do you agree that and OTR must be complemented with a penalty fee?

<ESMA_QUESTION_323>

AFME Response

As per FIA response:

AFME agrees that any mandatory OTR regime for instruments for which establishing an OTR is required (see question 293, p. 276 of the Discussion Paper) could be complemented by a penalty fee. This is consistent with current market practice, where many trading venues already have policies addressing message rates that have evolved over the past several years into effective mechanisms for controlling excessive messaging.

Typically, these policies are two-tiered in order to address two different aspects of message rate limits. The first level of limits is usually calculated and enforced on a daily or monthly basis as a means to deter market participants from consistently sending orders that are unlikely to be matched for execution. Although specific implementations of such a policy differ among trading venues, repeated violations of the policy typically lead to a fine, which acts as a deterrent to

similar behaviour in the future as well as to recoup the costs incurred by the trading venue to maintain systems capable of handling high levels of messaging.

The second level of limits is usually calculated and enforced on a real-time basis to prevent market participants from sending a large number of orders in a short enough period of time as to potentially harm the integrity of the trading venue. This limit is usually implemented as a short-term hard limit that prevents an offending market participant from sending additional orders for some amount of time.

It is difficult to standardize these types of policies across trading venues because trading systems and products vary among so much. Any regulation in this area should acknowledge the differences in markets and give trading venues the flexibility to configure their messaging policies, keeping in mind the unique characteristics of their products and the way they are traded. Requiring a messaging policy but allowing trading venue-by-trading venue and product-by-product flexibility will ensure the sound functioning of a liquid marketplace while meeting the objectives of ESMA.

Penalty fees should in any case not be imposed on any investment firm (not limited to market makers) when the breach of the OTR is the result of an exceptional circumstance within the meaning of Article 17(3) MiFID II. Under no circumstances do we believe a breach of an OTR should be sanctioned through the imposition of a trading ban or trading limitation on a market participant, as this could create additional and unnecessary risk. Finally, we reiterate our statement that market makers with continuous quoting obligation under Article 17(3) MiFID II should be exempted from the scope of the mandatory OTR regime as we indicated in our answer to Question 304. A market maker cannot control or anticipate how many of its orders will be matched by other members of the trading venue and will result in actual transactions. Therefore he can control his level of messaging but not the OTR this level of messaging will generate.

<ESMA_QUESTION_323>

Q324: In terms of the approach to determine the penalty fee for breaching the OTR, which approach would you prefer? If neither of them are satisfactory for you, please elaborate what alternative you would envisage.

<ESMA_QUESTION_324>

AFME Response

As per FIA response:

AFME strongly prefers Option A for the reasons stated in our answer to Q323 above. The purpose of introducing an OTR as required by Article 48(6) MiFID II is to ensure orderly trading conditions on trading venues by controlling the number of orders members may send to the matching engine of a trading venue in order to ensure the capacity of the latter is not exceeded. In this case, a homogenous methodology applicable to all trading venues may in fact create conditions for disorderly trading conditions, as each platform and its products can vary greatly. Moreover, trading venues that have invested in order to have more robust system with larger messaging capacity should therefore be able to apply different OTRs according to capacity of their systems.

<ESMA_QUESTION_324>



Q325: Do you agree that the observation period should be the same as the billing period?

<ESMA_QUESTION_325>

AFME Response

AFME agrees

<ESMA_QUESTION_325>

Q326: Would you apply economic penalties only when the OTR is systematically breached? If yes, how would you define “systematic breaches of the OTR”?

<ESMA_QUESTION_326>

AFME Response

AFME generally agrees and would defer to the trading venues as to how to define “systematic breaches.”

<ESMA_QUESTION_326>

Q327: Do you consider that market makers should have a less stringent approach in terms of penalties for breaching the OTR?

<ESMA_QUESTION_327>

AFME Response

As per FIA response:

Yes. As stated above, AFME believes that market makers subject to a Continuous Quoting Obligation (CQO) for a proportion of a trading venue’s trading hours that have entered into a binding written agreement as required under Article 17(3) MiFID should be exempt from any OTR regime. We agree with ESMA that any future OTR regime should preserve the market practice of permitting market makers to submit orders beyond the pre-established limit without surcharge.

<ESMA_QUESTION_327>

Q328: Please indicate which fee structure could incentivise abusive trading behaviour.

<ESMA_QUESTION_328>

TYPE YOUR TEXT HERE

<ESMA_QUESTION_328>

Q329: In your opinion, are there any current fee structures providing these types of incentives? Please elaborate.

<ESMA_QUESTION_329>

TYPE YOUR TEXT HERE

<ESMA_QUESTION_329>

4.8. Tick sizes (Article 48(6) and Article 49 of MiFID II)

Q330: Do you agree with the general approach ESMA has suggested?

<ESMA_QUESTION_330>

AFME Response

AFME believes an ongoing governance structure and future calibration will be key ingredients to the continued workability of the general approach suggested by ESMA.

<ESMA_QUESTION_330>

Q331: Do you agree with adopting the average number of daily trades as an indicator for liquidity to satisfy the liquidity requirement of Article 49 of MiFID II? Are there any other methods/liquidity proxies that allow comparable granularity and that should be considered?

<ESMA_QUESTION_331>

AFME Response

AFME believes that average number of trades is an adequate proxy for liquidity in this context. An alternative measure that could be considered by ESMA would be to include aggregate daily nominal value of the transactions in an instrument. AFME does not share ESMA's seeming concern about the "redundancy" in having share price as a factor in both the rows and columns of the matrix. Investors decide upon the number of share to buy or sell on basis of the nominal value and the number of shares is a resultant calculation driven by the price.

<ESMA_QUESTION_331>

Q332: In your view, what granularity should be used to determine the liquidity profile of financial instruments? As a result, what would be a proper number of liquidity bands?

<ESMA_QUESTION_332>

AFME Response

Four bands seems adequate but AFME would recommend that the governance structure that is developed to implement and maintain this structure has within its remit the ability to revise that number if that structure deems it appropriate upon investigating results post implementation

<ESMA_QUESTION_332>

Q333: What is your view on defining the trade-off between constraining the spread without increasing viscosity too much on the basis of a floor-ceiling mechanism?

<ESMA_QUESTION_333>

AFME Response

AFME feels that this is the central purpose of a well implemented tick size regime. The numbers quoted as floor and cap are arbitrary and should remain open to revision. The key advantage of Option 1 is that it allows for control testing of the optimisation process.

<ESMA_QUESTION_333>

Q334: What do you think of the proposed spread to tick ratio range?

<ESMA_QUESTION_334>

AFME Response

The proposed spread to tick ratio range looks reasonable provided the first review is scheduled close to the roll out of the structure. AFME is encouraged by the rigour with which Option 1 has been examined but believes it would be appropriate to review and recalibrate a potentially subjectively set starting range as deemed appropriate by a governance process that represents all important users of trading venues. However in setting any floor and ceiling levels it is vital that spreads are not artificially constrained by tick sizes, particularly as this creates cost for investors.

<ESMA_QUESTION_334>

Q335: In your view, for the tick size regime to be efficient and appropriate, should it rely on the spread to tick ratio range, the evolution of liquidity bands, a combination of the two or none of the above?

<ESMA_QUESTION_335>

AFME Response

Both factors are relevant and AFME recommends a combination would be more appropriate.

<ESMA_QUESTION_335>

Q336: What is your view regarding the common tick size table proposed under Option 1? Do you consider it easy to read, implement and monitor? Does the proposed two dimensional tick size table (based on both the liquidity profile and price) allow applying a tick size to a homogeneous class of stocks given its clear-cut price and liquidity classes?

<ESMA_QUESTION_336>

AFME Response

AFME believes the tick size table in Option 1 presents a good foundation from which to start and is easy to read, implement and monitor, in contrast to Option 2.

<ESMA_QUESTION_336>

Q337: What is your view regarding the determination of the liquidity and price classes?

<ESMA_QUESTION_337>

AFME Response



The price classes suggest themselves and look uncontentious. The liquidity classes seem a reasonable place to start when initiating this approach but a large part of the appeal of option 1 to AFME is the fact that these classes can evolve over time.

<ESMA_QUESTION_337>

Q338: Considering that market microstructure may evolve, would you favour a regime that allows further calibration of the tick size on the basis of the observed market microstructure?

<ESMA_QUESTION_338>

AFME Response

AFME favours a regime that allows further calibration. Microstructure aspects such as Order to trade ratio, European Transaction Tax should trigger further calibration of the tick size for example.

<ESMA_QUESTION_338>

Q339: In your view, does the tick size regime proposed under Option 1 offer sufficient predictability and certainty to market participants in a context where markets are constantly evolving (notably given its calibration and monitoring mechanisms)?

<ESMA_QUESTION_339>

AFME Response

At any

<ESMA_QUESTION_339>

Q340: The common tick size table proposed under Option 1 provides for re-calibration while constantly maintaining a control sample. In your view, what frequency would be appropriate for the revision of the figures (e.g., yearly)?

<ESMA_QUESTION_340>

AFME Response

Initially this should be done frequently, certainly within the first six weeks and perhaps twice more within the first year, until the calibration has stabilised. AFME would recommend that the body tasked to perform the re-calibration is left discretion as to the frequency but be mandated to do so no less frequently than annually.

<ESMA_QUESTION_340>

Q341: In your view, what is the impact of Option 1 on the activity of market participants, including trading venue operators? To what extent, would it require adjustments?

<ESMA_QUESTION_341>

AFME Response

Conforming to a pan European regime for ticks may require adoption of data feeds for some participants, including venue operators. The dramatic decrease in the maintenance effort required by the significant complexity and inefficiencies generated by the current disparate systems in AFME's view far outweighs any adoption effort. Furthermore the increased clarity that market participants will have as to prevailing ticks will improve ease of market access.

<ESMA_QUESTION_341>

Q342: Do you agree that some equity-like instruments require an equivalent regulation of tick sizes as equities so as to ensure the orderly functioning of markets and to avoid the migration of trading across instrument types based on tick size? If not, please outline why this would not be the case.

<ESMA_QUESTION_342>

AFME Response

This seems sensible, though AFME would suggest a phased approach, changing Equities in the first instance before other categories of instruments. This would allow an opportunity to bed in the changes and work through the implementation, and enable to application of any lessons learned for subsequent categories.

<ESMA_QUESTION_342>

Q343: Are there any other similar equity-like instruments that should be added / removed from the scope of tick size regulation? Please outline the reasons why such instruments should be added / removed?

<ESMA_QUESTION_343>

AFME Response

AFME sees no reason that a version of Option 1 could not be devised for any equity like instruments and all should be considered as candidates for subsequent adoption.

<ESMA_QUESTION_343>

Q344: Do you agree that depositary receipts require the same tick size regime as equities'?

<ESMA_QUESTION_344>

AFME Response

Yes

<ESMA_QUESTION_344>



Q345: If you think that for certain equity-like instruments (e.g. ETFs) the spread-based tick size regime¹⁷ would be more appropriate, please specify your reasons and provide a detailed description of the methodology and technical specifications of this alternative concept.

<ESMA_QUESTION_345>

AFME Response

Given the flexibility and evolutionary nature of Option 1 AFME sees no reason to adopt an alternate approach for equity-like instruments.

<ESMA_QUESTION_345>

Q346: If you generally (also for liquid and illiquid shares as well as other equity-like financial instruments) prefer a spread-based tick size regime¹⁸ vis-à-vis the regime as proposed under Option 1 and tested by ESMA, please specify the reasons and provide the following information:

<ESMA_QUESTION_346>

AFME Response

AFME understands the floor and ceiling limits in Option 1 mean that it represents a “spread-based” regime so we don’t understand this question.

<ESMA_QUESTION_346>

Q347: Given the different tick sizes currently in operation, please explain what your preferred type of tick size regulation would be, giving reasons why this is the case.

<ESMA_QUESTION_347>

AFME Response

AFME’s preferred type of tick size regulation would be a rigorously administered pan European regime resulting in the removal of discretion from trading venues. Repeatedly the existence of such discretion has resulted in it being exercised in such a way as to damage the efficiency of the European equity market, this must be prevented in the future. Separately the disparate regimes at present introduce unnecessary inefficiency and risks to no benefit. This was implicitly acknowledged in the attempts made to introduce standardisation that culminated in the creation of the tables referred to as FESE tables. Those tables were in themselves a compromised construct as witnessed by their lack of symmetry designed to meet narrow venue concerns. Moreover, they have not only never been fully adopted, the partial adoption has in some instances been reversed.

<ESMA_QUESTION_347>

¹⁷ Please see the description of Option 2 regarding tick sizes below.

¹⁸ Please see the description of Option 2 regarding tick sizes below.



Q348: Do you see a need to develop a tick size regime for any non-equity financial instrument? If yes, please elaborate, indicating in particular which approach you would follow to determine that regime.

<ESMA_QUESTION_348>

AFME Response

Option 2 does not offer the requisite granularity, and otherwise AFME sees no benefits in Option 2 over Option 1. Its construct seems contrived to use the liquid and illiquid lists of stocks while acknowledging that more than two sets of ticks are required. To reconcile these two the approach purports to slide stocks up and down a single tick table using the SAF mechanism. This is equivalent to having a separate column.

<ESMA_QUESTION_348>

Q349: Do you agree with assessing the liquidity of a share for the purposes of the tick size regime, using the rule described above? If not, please elaborate what criteria you would apply to distinguish between liquid and illiquid instruments.

<ESMA_QUESTION_349>

AFME Response

Option 2 does not offer the requisite granularity, and otherwise AFME sees no benefits in Option 2 over Option 1. Its construct seems contrived to use the liquid and illiquid lists of stocks while acknowledging that more than two sets of ticks are required. To reconcile these two the approach purports to slide stocks up and down a single tick table using the SAF mechanism. This is equivalent to having a separate column.

<ESMA_QUESTION_349>

Q350: Do you agree with the tick sizes proposed under Option 2? In particular, should a different tick size be used for the largest band, taking into account the size of the tick relative to the price? Please elaborate.

<ESMA_QUESTION_350>

AFME Response

AFME sees no benefits in option 2 over option 1.

<ESMA_QUESTION_350>

Q351: Should the tick size be calibrated in a more granular manner to that proposed above, namely by shifting a band which results in a large step-wise change?

<ESMA_QUESTION_351>

AFME Response

AFME sees no benefits in option 2 over option 1.

<ESMA_QUESTION_351>



Q352: Do you agree with the above treatment for a newly admitted instrument? Would this affect the subsequent trading in a negative way?

<ESMA_QUESTION_352>

AFME Response

No, the above treatment is completely inefficient. There can be dramatic changes in the liquidity profile in the first few weeks of trading of a newly listed stock, consequently this is not a good benchmark.

<ESMA_QUESTION_352>

Q353: Do you agree that a period of six weeks is appropriate for the purpose of initial calibration for all instruments admitted to the pan-European tick size regime under Option 2? If not, what would be the appropriate period for the initial calibration?

<ESMA_QUESTION_353>

AFME Response

No. The sample is not sufficient. It is not even certain than in a six weeks period one can observe triple witching (options expiry). In any case, optimising these periods should be part of the remit of the governance structure implemented for either option.

<ESMA_QUESTION_353>

Q354: Do you agree with the proposal of factoring the bid-ask spread into tick size regime through SAF? If not, what would you consider as the appropriate method?

<ESMA_QUESTION_354>

AFME Response

No. SAF is a very complex approach, which creates representational ambiguity and implementation complexity. Ironically software engineers would be likely to look through the SAF construct and implement it as additional sets of tick tables rather than offsets on the arbitrarily allocated table in which the stocks start.

<ESMA_QUESTION_354>

Q355: Do you agree with the proposal to take an average bid-ask spread of less than two ticks as being too narrow? If not, what level of spread to ticks would you consider to be too narrow?

<ESMA_QUESTION_355>

AFME Response

Reiterating our response to questions 330 and 340 above with regard to Option 1 the starting point is not as important as having a review mechanism that is empowered and diligent.



<ESMA_QUESTION_355>

Q356: Under the current proposal, it is not considered necessary to set an upper ceiling to the bid-ask spread, as the preliminary view under Option 2 is that under normal conditions the risk of the spread widening indefinitely is limited (and in any event a regulator may amend SAF manually if required). Do you agree with this view? If not, how would you propose to set an upper ceiling applicable across markets in the EU?

<ESMA_QUESTION_356>

AFME Response

No, an upper ceiling is required. Stocks can certainly have ticks that are too small resulting in a spread of too many ticks. Any option adopted should acknowledge that and allow for it. The approach in Option 1 looks like a pragmatic place to start.

<ESMA_QUESTION_356>

Q357: Do you have any concerns of a possible disruption which may materialise in implementing a review cycle as envisioned above?

<ESMA_QUESTION_357>

AFME Response

Yes, the envisioned cycle review is extremely short, and annual review is too infrequent while a new approach is bedding in.

<ESMA_QUESTION_357>

Q358: Do you agree that illiquid instruments, excluding illiquid cash equities, should be excluded from the scope of a pan-European tick size regime under Option 2 until such time that definitions for these instruments become available? If not, please explain why. If there are any equity-like instruments per Article 49(3) of MiFID II that you feel should be included in the pan-European tick size regime at the same time as for cash equities, please list these instruments together with a brief reason for doing so.

<ESMA_QUESTION_358>

AFME Response

No

<ESMA_QUESTION_358>

Q359: Do you agree that financial instruments, other than those listed in Article 49(3) of MiFID II should be excluded from the scope of the pan-European tick size regime under Option 2 at least for the time being? If not, please explain why and which specific instruments do you consider necessary to be included in the regime.

<ESMA_QUESTION_359>

AFME Response



AFME agrees with a phased adoption of either option but would make broad applicability an explicit near term goal.

<ESMA_QUESTION_359>

Q360: What views do you have on whether tick sizes should be revised on a dynamic or periodic basis? What role do you perceive for an automated mechanism for doing this versus review by the NCA responsible for the instrument in question? If you prefer periodic review, how frequently should reviews be undertaken (e.g. quarterly, annually)?

<ESMA_QUESTION_360>

AFME Response

As we understand it in both options the tick size is adjusted dynamically as price limits are traversed. This is overlaid with “manual” periodic review of calibration. This appears to be the correct way to design the system. ESMA should be responsible for the review of the Tick Sizes and not the NCA, which would result in an unworkable process. We believe the governance process should mandate a review after 4 or 6 weeks post implementation and thereafter at least annually. However the governance process must have clear authority to review more frequently as they see fit. Initially we would envisage a frequent review but as the system beds in this can move out towards the allowable maximum of annually.

<ESMA_QUESTION_360>

5. Data publication and access

5.1. General authorisation and organisational requirements for data reporting services (Article 61(4), MiFID II)

Q361: Do you agree that the guidance produced by CESR in 2010 is broadly appropriate for all three types of DRS providers?

<ESMA_QUESTION_361>

AFME Response

No. AFME does not agree.

i. CESR's 2010 requirement relating to APAs

We do not believe, given the outcome of MiFID/R, that the CESR 2010 guidance remains fit for purpose. We believe elements still apply but should not be adopted in totality. Specifically, given the nature of the transparency calibrations (e.g. CESR did not envision liquidity calibrations), the determination of the functionality of the APAs will be essential for ensuring an operationally workable regime for fixed income that produces meaningful post trade data. Therefore, it is essential that the CESR guidance is revised significantly.

Key aspects of the APA identified under MiFID/R are:

- Investment firms will need comply with their post trade transparency obligations by making the trades public through an APA (MiFIR Article 21(1));
- In order to carry out the calculations for determining the requirements for the pre trade and post trade transparency, NCAs may require information from APAs (MiFIR Article 22); and
- Each individual transaction shall be made public once through a single APA (MiFIR Article 21(2)).

Given the above, it is clear that APAs will have a critical role in facilitating the calibration calculations and ensuring that a trade is published once (i.e. only one APA can publish any single trade) – which are key functional aspects of the infrastructure of the transparency regime. We do not believe that the CESR guidance incorporates the functionality needed to support these key aspects of APAs.

We stress that it is vital that the operational structure of MiFID is simple and workable to ensure: (i) good quality non-duplicative consistent data is published and is used for calibration purposes; and (ii) an IBIA approach together with a monthly dynamic calibration is feasible.

We recommend that an APA should need to meet the following high level requirements in order to be approved as an APA – so that the above objectives can be met. These requirements are explained in more detail below.

| | APA high level requirement |
|---|----------------------------|
| A | Receive trade reports |

| | |
|---|---|
| B | Validation of information (identification of incomplete or potentially erroneous information) |
| C | Correction of trade information/error management |
| D | Application of reportability logic |
| E | Dissemination |
| F | Production of calibration templates |
| G | Management information and accessibility |
| H | Security |
| I | Monitoring |
| J | Operational hours |
| K | Resources and contact arrangements |
| L | Recovery provisions |
| M | Conflicts of interest |
| N | Outsourcing |
| O | Regulatory reporting responsibilities |

We recommend that the APA’s requirements can be grouped into the following four categories:

1. Publication function
2. Preparation of information for pre and post trade calibration function
3. Information management
4. Infrastructure

1. Publication functions

With regards to the publication function, the APA needs be able to undertake a number of processes:

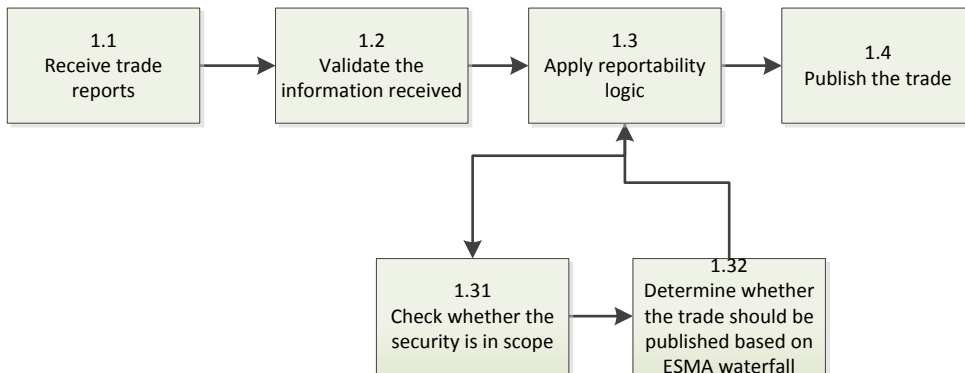

These functions are explained below and should be included in the requirements that the APA should meet to be authorised by the NCA.

| Essential functions of APAs | Details of the requirement | Purpose |
|-----------------------------|---|---|
| A. Receive trade reports | <ul style="list-style-type: none"> • APAs should be able to receive the data industry standard formats. APAs need to be able to receive trade information from different types of investment firms. <p>It should not be difficult for an investment firm to switch from one APA to another as a result of technological barriers.</p> <ul style="list-style-type: none"> • APAs should be able to receive a minimum number of fields. These fields should include: <ul style="list-style-type: none"> - The fields/flags for publication - Processing fields/flags: i.e. fields needed to apply the reportability logic (as set out below) • APAs should receive trade reports in the form of standardised formatting determined by the ESMA Data Group • APAs need to provide versioning in relation to trades submitted. Firms | <p>This ensures that APAs are accessible to all investment firms, such that investment firms do not need make significant changes to their infrastructure to change from one APA to another. The fact that there can be multiple APAs suggests that they need to be competitive.</p> <p>If a firm chooses to not apply suppression logic in-house, it is essential that all APAs can receive the data to apply reportability logic (see AFME’s response to DP Question 132. We strongly recommend that the more firms utilise the reportability logic of APAs, the more consistent and non-duplicative published trade details will be. It is highly likely that there will be less APAs that investment firms; therefore, the concentration of reportability logic on APAs will enhance the quality of post trade data. Further, if firms have the option to send APAs all information rather than building in-house suppression</p> |

| | | |
|--|---|--|
| | <p>need to be able to update their trade reports to the APA but have access to the historical submissions in relation to the same trade.</p> <ul style="list-style-type: none"> • APAs should have cross-border arrangements in place | <p>logic, it is more likely that they will use this functionality because it enables firms to utilise existing reporting data flows.</p> |
| <p>B. Validate the information received</p> | <ul style="list-style-type: none"> • CESR’s proposed requirements - validation of the data itself (e.g. price checking) • Format checking and validation • APA must not publish trade reports that it receives and determines as erroneous • Provide reasons for rejections to the investment firm and have a reconciliation procedure in place • APA to provide the submitter with alerts | <p>Validation of data received is essential for detecting and resolving errors.</p> <p>As CESR has identified, APAs must be able to identify incomplete or potentially erroneous information. AFME agrees with the CESR specifications; however, format checking is missing. It also needs to inform the submitter with alerts regarding errors from the validation process.</p> <p>In addition to checking for erroneous information, the APA needs to have a reconciliation process in place. The APA also needs to inform the investment firm of the reasons for any rejections and the status of the trade submission. The communication that the APA needs to provide to the data submitter is a vital feature of the APA.</p> <p>We note that CESR mentions the APA should provide alerts. We stress that the APA should provide more than alerts to be fit for purpose. APAs should provide investment firms submitting trades real time access and an audit trail.</p> |
| <p>C. Correction of trade information/error management</p> | <ul style="list-style-type: none"> • APAs must have a reconciliation process/procedure in place once the APA has identified an error and provided an | |

| | | |
|------------------------------|---|---|
| | <p>alert to the investment firm</p> <ul style="list-style-type: none"> • APA should enable the firm to provide corrections and updates • APA should be able to receive and process cancellations and amendments • We agree with CESR’s proposal except that an APA should only be able to correct data at the request of the firm submitting the information. | |
| D. Apply reportability logic | <ul style="list-style-type: none"> • Look up whether security is in scope <ul style="list-style-type: none"> - Look up security in the list of instruments in scope maintained by ESMA - From the flags provided by the data submitter (as provided in our response to DP Question 135) • Apply data quality waterfall – using the populated process fields which are received by the APA when a firm opts for the APA to apply the reportability logic | <p>As mentioned above and in response to DP Question 132, it is essential that APAs are able to apply waterfall suppression logic (if the firm does not do so itself) so as to ensure that trades are not duplicated and only one trade is published and each APA publishes a unique data set.</p> <p>Further, the reportability logic ensures that there does not need to be a trade repository for bonds for the calculation of the liquidity calibration (every APA has a unique data set) – a repository based system is highly complex and cannot support a dynamic calibration (see AFME’s response to DP Question 178).</p> <p>An investment firm may opt to apply the reportability logic themselves but it is essential that APAs have this functionality.</p> <p>The reportability logic is explained below.</p> |
| E. Dissemination | <ul style="list-style-type: none"> • The APA needs to apply the calibration for the security/trade submitted by | <p>The APA needs to be able to apply the appropriate time delays relevant for the trade it re-</p> |

| | | |
|--|--|--|
| | <p>looking up the calibration status of the security/trade in question (i.e. whether the instrument liquid/illiquid, whether it applies for an SSTI/LIS delay)</p> <ul style="list-style-type: none"> • The publication needs to take place within the timeframe specified by the RTS • The APA should apply the public flags provided by the investment firm and as required by the RTS • Make the data available to the public • The trade data must be consolidatable and in a minimum standardised format (please see AFME’s response to DP Question 132) • CESR’s proposed dissemination requirements | <p>ceives. Investment firms should not be required to identify the publication time themselves and inform the APA. Such an approach is operationally duplicative and more costly. Firms may decide they wish to contractually agree with the APA that they would like to indicate the delays to the APAs. However, it is essential that the APA has the functionality check the timeframe of publication of the trade (i.e. if the security is illiquid or there is a LIS or SSTI deferral).</p> <p>It is critical that the APA publishes the trade within the correct timeframe or waits to publish the trade until after the deferral/extended deferral period has lapsed.</p> <p>As discussed in response to DP Question 135, certain public flags are necessary. Therefore, APAs should be required to publish trades with the necessary public flags.</p> <p>We agree with CESR’s proposed guidance on dissemination. However, the additional requirements we propose under dissemination is fundamental.</p> <p>In order for the public trade data to be useable and meaningful for price discovery purposes, it needs to be consolidatable. To be consolidatable, APAs need to publish the data in a format and language that complies with minimum standards.</p> |
|--|--|--|

- **Reportability logic**

As discussed above, reportability logic is essential to ensuring a trade is only reported once by one APA in a consistent manner. Without a clear protocol in place, the high level of OTC trades in fixed income will result in poor quality public post trade data that is duplicative and unusable data sets for the purposes of calibration.

We propose that a simple protocol can be applied that does not require a complex communication network between APAs or investment firms. Such a protocol involves the APA applying a waterfall protocol to the non-public data fields it receives. It is important that investment firms can apply the logic itself; however, we would like as many trades as possible to go through the protocol at the APA level rather than through the investment firm. Therefore, this functionality needs to be an essential part of the APA requirement to encourage the application of the waterfall through the APA.

AFME proposes the following waterfall logic:

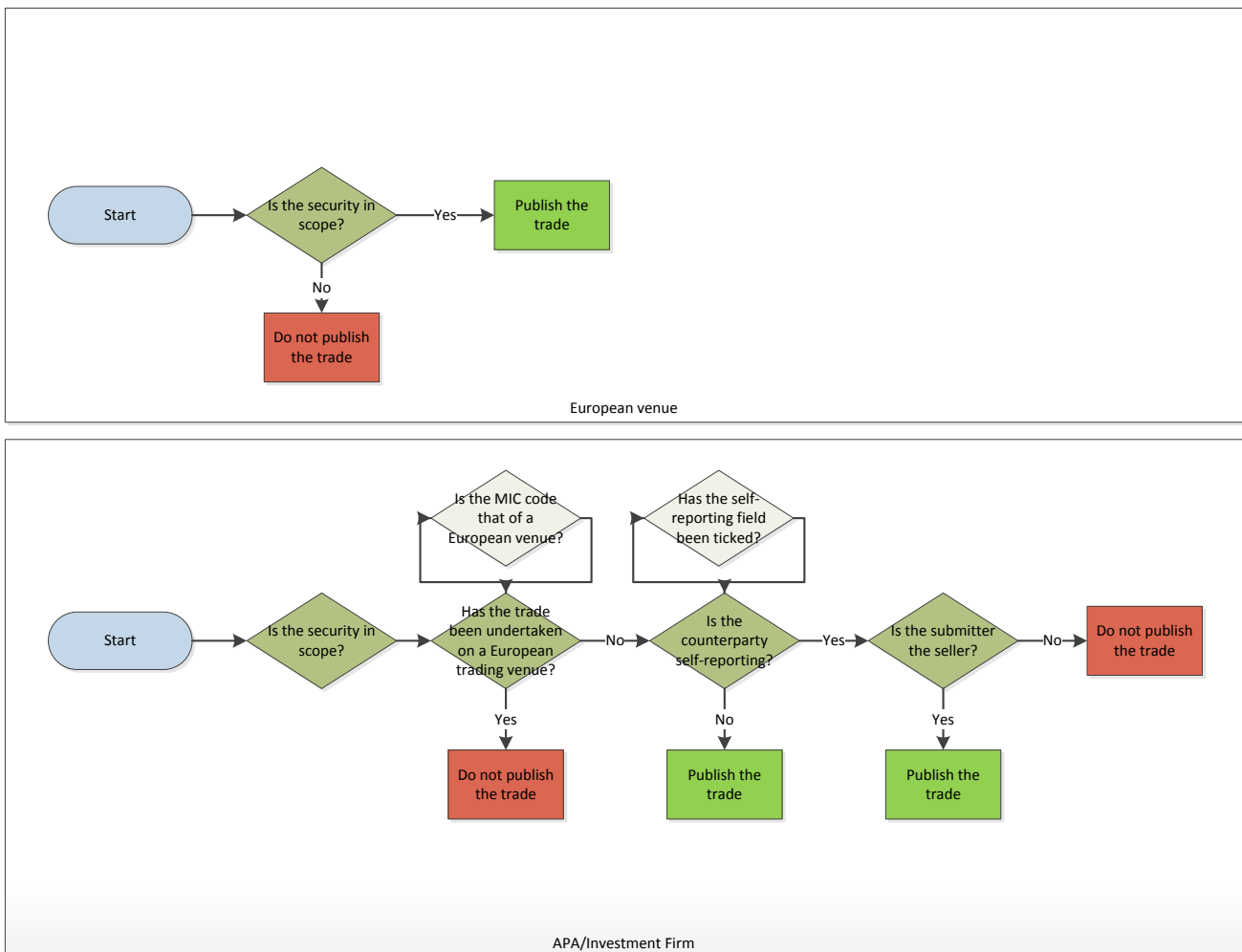

The waterfall works as follows: (i) European venues always publish their trades; (ii) if the APA receives a trade from an investment firm and it has been undertaken on a European venue, the APA should not publish the trade (it should suppress it); (iii) if the trade has not been undertaken on a European trading venue, if the counterparty of the submitting investment firm is not a self-reporting entity, then the APA should publish the trade; and (iv) if the counterparty of the sub-

mitting investment firm is a self-reporting entity, then the APA should only publish the trade if the reporting investment firm is the seller.

We stress that investment firms may opt to apply the reportability logic themselves but it is essential that APAs have this functionality. If an investment firm applies the reportability logic – they need to apply the same waterfall.

As set out in our response to **DP Question 132**, if the investment firm opts to have the APA apply the reportability logic, the following fields need to be submitted to the APA for the waterfall to be applied. Again the waterfall can be applied by the investment firm but we believe that ESMA should encourage as many of the waterfalls to be applied by APAs as possible by requiring APAs to have this functionality.

| Field | Explanation and purpose |
|--|---|
| MIC code of venue | <p>This is to identify whether the trade has already been published through a European venue. If it has, the APA should suppress the trade publication, otherwise the same trade will be published two or three times, creating distortions in the market.</p> <p>The MIC code is the identifier code of the venue. Notably, only European venues are subject to the post trade publication rules; therefore, it is essential for ESMA to maintain and publish a list of all European registered trading venues together with their MIC codes to ensure that APAs and firms can identify whether the trade will already be published.</p> |
| Is the counterparty to the trade self-reporting (Yes/No) | <p>There will be a bilateral contractual arrangement between dealers and each of their counterparties as to whether their counterparties will delegate reporting and thereby take up a non-self-reporting status. It should be noted these are bilateral arrangements and a counterparty may choose to be self-reporting with one dealer and non-self-reporting with another.</p> <p>It is important for firms to populate this field to identify whether two self-reporting parties will publish the trade through an APA (which may very well be different APAs).</p> |

| | |
|-------------------|--|
| | In order for a waterfall to be applied to ensure that there is no duplicative reporting, this field is essential. |
| Buyer/Seller | This field is important for, again, the application of the waterfall to ensure that there is no duplicative reporting. In the event that there are two self-reporting counterparties sending the trade to APAs, the APA receiving the buyer's information will suppress the trade and the APA receiving the seller's trade will publish the information |
| On behalf of LEI | <p>If a client delegates its reporting requirements to a firm and that firm is not a counterparty to a trade, it is important for the LEI of that client to be reported to the LEI (e.g. in the case of delegation of post trade processing and reporting).</p> <p>This is because, it is important that when an APA sends publication confirmations back to the firm, the firm will be able to differentiate between its own trades and those of its clients.</p> <p>If such delegation does not take place, this field should be left blank.</p> |
| Transmission time | This is important to ensure compliance with the requirements. It will keep a track of the submission of information to the APA, which can then be compared to the publication time. |

2. Preparation of the information for pre and post trade transparency (functionality F)

As set out in our response to **DP Question 178** (Section 3.13), it is essential that APAs are required to produce regular reports for their NCAs to be sent to ESMA for the purposes of transparency calibration. Specifically, to ensure a simple operational model whereby regular dynamic calibration can be achieved, APAs will need to produce these aggregate reports in a standardised format. Given that the data produced by the APA will be unique following the application of the waterfall, ESMA can aggregate the aggregate reports from the APAs and venues easily and thereby produce a calibration. The diagram below illustrates the process:

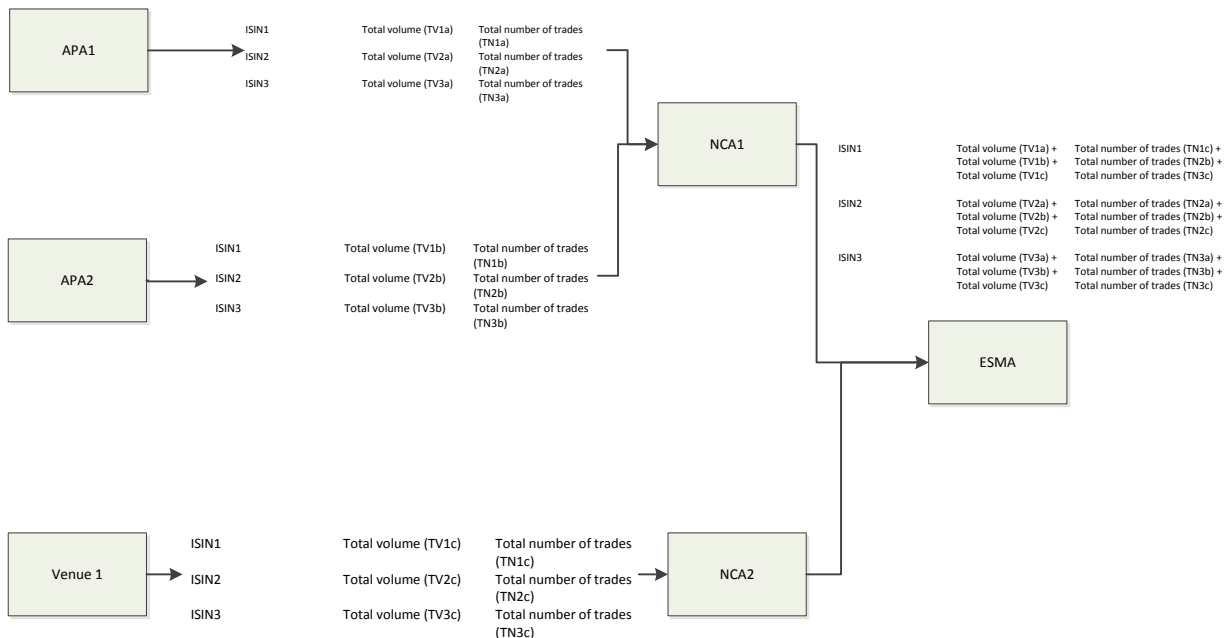

3. Information management – these requirements relate to how the APA handles and organises the information it receives and how it communicates/provides information to the investment firms submitting the information.

| Essential requirement of APAs | Detail of requirement | Purpose/explanation |
|---|--|--|
| G. Management information and accessibility | <ul style="list-style-type: none"> Industry standard format – for each trade submitted, firms need to be able to see: <ul style="list-style-type: none"> The ID of the trade submission The receipt time The publication time Updates Statuses Error messages Machine readability – the information provided to firms needs to be machine | <p>These functionalities are essential for ensuring that firms can easily and consistently submit and monitor and access the data they have submitted – in a standardised format across all APAs – so that they can fulfil their transparency requirements.</p> <p>Investment firms submitting the information need to be able to identify when and whether a trade has been submitted. This is to ensure firms can track their compliance with the requirement in</p> |

| | | |
|--|--|--|
| | <p>readable.</p> <ul style="list-style-type: none"> • Statuses – APAs need provide firms with the ability to track the statuses of the trades submitted. Statuses include: <ul style="list-style-type: none"> - Confirmation of receipt of the trade - Time of receipt of the trade - Whether the trade has been published - Time of publication - Whether the trade has been suppressed - Whether the trade is being held for deferral - Whether there is an error and publication can not take place and the reason for rejection - If there has been a cancellation or amendment to the trade or a fix – the historical status of the trade from receipt to publication (with the provision of versioning as above). • APAs should provide live and historical information of submissions (at least 2 months of information for trades that have been published and trades that have not been fully reported should be available) • Information relating to submitted trades should be freely available to submitter and also able to send reports to delegates | <p>real time and have a clear audit trail. However, they also need to be able to following the flow of a trade that has been updated (e.g. correction of an error) or an amendment of a trade.</p> <p>Additionally, they need to be able to access the information they have submitted – for live submissions (e.g. trades that have not yet been submitted due to a deferral) and for a reasonable amount of historical data.</p> |
|--|--|--|

4. Infrastructure

| Essential requirement of APAs | Detail of requirement | Purpose |
|---------------------------------------|---|---|
| H. Security | <ul style="list-style-type: none"> • CESR's proposed requirements • APAs should check whether fields are corrupted prior to processing the information | We agree with CESR's proposed requirements. However, APAs should also check whether the fields they receive are corrupted. |
| I. Monitoring | <ul style="list-style-type: none"> • CESR's recommendation | We agree with CESR's recommendation |
| J. Operational hours | <ul style="list-style-type: none"> • CESR's recommendation except that the APA should be able to receive trade data from submitters 24 hours a day and 7 days a week (including public holidays) | We agree with CESR's recommendations. However, trades may be conducted outside of the APA's business hours and different countries have different holidays; therefore, APAs must be able to receive the information any time of day on any day. Most these processes will be automated by the investment firm – therefore, there needs to be a receiving end at all times. The APA should not be required to process the information it receives outside of its business hours. |
| K. Resources and contact arrangements | <ul style="list-style-type: none"> • CESR's recommendations | We agree with CESR's recommendations |
| L. Recovery provisions | <ul style="list-style-type: none"> • The APA should have a back-up system in place • CESR's recommendations | We agree with CESR's recommendations. However, the APA should be required to have a back-up system in place so that disruptions do not result |

| | | |
|---|---|--|
| | | in investment firms failing to meet their transparency requirements |
| M. Conflicts of interest | <ul style="list-style-type: none"> • CESR's recommendations | We agree with CESR's recommendations. |
| N. Outsourcing | <ul style="list-style-type: none"> • The APA should not pass on any confidential information to a third party without prior contractual agreement with the firm submitting the data • APAs should ensure that the third party has appropriate security systems in place • Agree with CESR's requirements | APAs will receive highly sensitive commercial information from investment firms. Therefore, it is essential that this information is not disseminated without the prior agreement of the submitter of the information. It is crucial that an APA cannot pass on information to a third party who then uses it for their own purposes (e.g. selling the information) – without the prior consent of the firm submitting the data to the APA. Further, it is essential that the third party has the appropriate security systems in place to ensure that the information is protected. |
| O. Regulatory reporting responsibilities | <ul style="list-style-type: none"> • The APAs should also send the periodic report to the submitting firms relating only to the information that each of those firms submitted | Whilst periodic reports have a role for regulators. It is important that APAs also send these reports to investment firms in relation to the data they have submitted. This is to enable firms to monitor their compliance with the requirements. |
| P. Governance in relation to investment firm data | <ul style="list-style-type: none"> • APAs should only use the data for the purposes as set out under the RTS and any other purpose as expressly agreed between the information providers and the APA. | Given the commercially sensitive nature of the data being provided to the RTS – it is important that the APA does not use the data for any purpose (outside the RTS re- |

| | | |
|-------------------|---|---|
| | | quirements) other those agreed between the provider of the information and the APA. |
| Q. Infrastructure | <ul style="list-style-type: none"> • Light technology requirements for submitters – shouldn't be a significant technology burden for user firms • There should be a portal available for information submission and access to information • Ability to have low cost and simple connectivity • APAs should have a thinline option available | It should not be difficult and highly costly for investment firms to access the APA systems – this is even more important for small firms |

ii. Whether the requirements are appropriate for all three types of DRS providers

Elements of AFME's proposed APA requirements will be relevant to ARMs and CTPs. The CESR requirements (including APA's proposals) are not directly and fully applicable to CTPs and ARMs. There will need to be significant differences in the requirements. The roles (and thereby the functionality) of the APA, ARM and CTP are different; therefore, a one size fits all approach cannot work. We propose that there needs to be specific requirements for all three types of DRS to ensure that they fulfil their roles under MiFID II in the appropriate manner. Differences in the CTP requirements will be even more notable because the CTP is collecting public data, whereas the APAs and ARMs are not. Further, the security of the ARMs will be of critical importance given that it will be receiving the greatest amount of non-public information.

Below, we propose how AFME's proposed requirements for APAs should apply to ARMs and CTPs.

| | APA high level requirement | APA | ARM | CTP |
|---|----------------------------|-----|--|--|
| A | Receive trade reports | YES | YES - But the APA will need different standards because it will be receiving different fields | NO Perhaps except to collect minimum fields for consolidation |

| | | | | |
|---|---|-----|--|--|
| | | | - The requirements regarding processing fields are not relevant | |
| B | Validation of information (identification of incomplete or potentially erroneous information) | YES | YES - Except that rather than “not publishing”, it must not submit the trades to the NCA | NO |
| C | Correction of trade information/error management | YES | YES | NO |
| D | Application of reportability logic | YES | NO | NO |
| E | Dissemination | YES | NO - These will need to relate to the format of the data submitted to the NCAs rather than the public | PARTIALLY - The additional requirements AFME has proposed for APAs under dissemination do not apply to CTPs - The CESR requirements apply except that the publication must take place within a given timeframe |
| F | Production of calibration templates | YES | NO | PARTIALLY - The CTP may be required to populate calibration templates but is |

| | | | | |
|---|--|-----|--|--|
| | | | | not in a position to produce the same templates as APAs |
| G | Management information and accessibility | YES | <p>YES</p> <ul style="list-style-type: none"> - ARMs serve a different purpose from APAs, whereby a firm may wish to correct historical information – ARMs should enable firms to access and update at least 5 years of historical data | <p>NO</p> <ul style="list-style-type: none"> - Except that it would be helpful if the CTP made available the historical consolidated information (e.g. for the last 5 years) – in order for that information to be useful |
| H | Security | YES | <p>YES</p> <ul style="list-style-type: none"> - ARM should have the strictest security regime given it will be receiving a high level of non-public information | <p>YES</p> <ul style="list-style-type: none"> - But not to the same level as APAs and ARMS because the data is public. The CTP needs to ensure that the information is not hacked and changed by the third party (which could result in false information being provided to the market) |
| I | Monitoring | YES | YES | YES |
| J | Operational hours | YES | YES | YES |
| K | Resources and contact arrangements | YES | YES | <p>PARTIALLY</p> <ul style="list-style-type: none"> - A CTP does not need an account |

| | | | | |
|---|---------------------------------------|-----|-----|--|
| | | | | manager for data submitters given they are collecting public information |
| L | Recovery provisions | YES | YES | YES |
| M | Conflicts of interest | YES | YES | YES |
| N | Outsourcing | YES | YES | PARTIALLY - AFME's additional requirements do not apply |
| O | Regulatory reporting responsibilities | YES | YES | YES - But the reports will differ |

<ESMA_QUESTION_361>

Q362: Do you agree that there should also be a requirement for notification of significant system changes?

<ESMA_QUESTION_362>

AFME Response

Yes. AFME agrees

<ESMA_QUESTION_362>

Q363: Are there any other general elements that should be considered in the NCAs' assessment of whether to authorise a DRS provider?

<ESMA_QUESTION_363>

AFME Response

FIXED INCOME:

Yes. Please see AFME's response to **DP Question 361**.

<ESMA_QUESTION_363>

5.2. Additional requirements for particular types of Data Reporting Services Providers

Q364: Do you agree with the identified differences regarding the regulatory treatment of ARMs.

<ESMA_QUESTION_364>

AFME Response

Yes. AFME agrees. Please see AFME's response to **DP Question 361** which outlines the key differences between ARMs and APAs.

<ESMA_QUESTION_364>

Q365: What other significant differences will there have to be in the standards for APAs, CTPs and ARMs?

<ESMA_QUESTION_365>

AFME Response

Please see AFME's response to **DP Question 361** for its proposal on the different standards for APAs, ARMs and CTPs.

<ESMA_QUESTION_365>

5.3. Technical arrangements promoting an efficient and consistent dissemination of information – Machine readability Article 64(6), MiFID II

Q366: Do you agree with the proposal to define machine-readability in this way? If not, what would you prefer?

<ESMA_QUESTION_366>

AFME Response

No. AFME does not agree.

(i) *The location of the data should be known but not the location of the storage device*

We do not believe the requirement for “*the data to be on a location on a computer storage device where that location is known in advance by the party wishing to access the data*” is meaningful or helpful – it is also unduly onerous. A party wishing to access the data should know where to find the information but that party doesn't need to know the location of where it is stored. For example, if the information is put on a website, the party should know the location of the website where it can access the data but the party does not need to know the location of the servers where the data is stored.

Therefore, we propose for the second requirement to be amended to:

“is in a location that is known in advance by the party wishing to access the data. Data may also be located in a website, in which case it shall remain accessible by electronic means through an automated process.”

(ii) *The data needs to be available in a format that is widely used and recognised*

It is important for data to be machine readable and available in a format which is widely used and recognised. It is important that firms do not have to build new infrastructure every time they wish to access data produced under MiFID II. This is even more important for small firms.

Therefore, we propose for the third requirement to be amended to:

“is available in a format that is widely known and used by the industry. Format includes in particular types of files and messages, the rules to identify them, and the name and data types of the fields they contain. Instructions outlining how users can access the data shall be made easily and continuously available to all parties wishing to access the data.”

(iii) ***The data must not be encoded***

We recommend for there to be an additional requirement whereby the data should not be encoded. Encoded data would introduce accessibility restrictions.

<ESMA_QUESTION_366>

5.4. Consolidated tape providers

Q367: Should the tapes be offered to users on an instrument-by-instrument basis, or as a single comprehensive tape, or at some intermediate level of disaggregation? Do you think that transparency information should be available without the need for value-added products to be purchased alongside?

<ESMA_QUESTION_367>

AFME Response

AFME believes that there should be an option for tapes to be available to users at an instrument-by-instrument level, as long as the costs are reasonable. The CTPs should be able to price complete tapes and disaggregated data differently (at a reasonable level).

Greater levels of disaggregation is more important for smaller firms that cannot buy the whole tape or do not wish to purchase data relating to markets in which they do not participate.

<ESMA_QUESTION_367>

Q368: Are there other factors or considerations regarding data publication by the CTP that are not covered in the standards for data publication by APAs and trading venues and that should be taken into account by ESMA?

<ESMA_QUESTION_368>

AFME Response

Yes. AFME recommends that CTPs should make available greater levels of historical data than APAs given the nature of the CTP function. Please see our response to **DP Question 361**. Further, the data needs to be made accessible in a format that is usable to less sophisticated audiences.

<ESMA_QUESTION_368>

Q369: Do you agree that CTPs should be able to provide the services listed above? Are there any others that you think should be specified?

<ESMA_QUESTION_369>

AFME Response

Yes. AFME agrees. However, we do not agree that the RTS should list the other services that a CTP can provide. We believe that the CTP should be able to undertake any other business as long as it does not conflict with its CTP functionality (e.g. there may be a conflicts management process in place).

In fact, CTP functionality may not be the primary business of the CTP – it is important that firms intending to act as CTPs are not required to adopt this functionality as its main business. Otherwise, only new businesses or legal entities could become CTPs.

<ESMA_QUESTION_369>

5.5. Data disaggregation

Q370: Do you agree that venues should not be required to disaggregate by individual instrument?

<ESMA_QUESTION_370>

AFME Response

Yes. AFME partially agrees

AFME believes that there should be an option for data to be available to users at an instrument-by-instrument level, as long the costs are reasonable. Venues should be able to price granular disaggregated data differently (at a reasonable level).

Greater levels of disaggregation is more important for smaller firms that cannot buy the whole tape or do not wish to purchase data relating to markets in which they do not participate.

We agree that it should be possible for a venue to be waived from the requirement if they can demonstrate that there is insufficient customer interest. ESMA may consider circumstances where disaggregation would be excessively costly. It is important for venue trading costs not to increase as a result of excessive disaggregation requirements

<ESMA_QUESTION_370>

Q371: Do you agree that venues should be obliged to disaggregate their pre-trade and post-trade data by asset class?

<ESMA_QUESTION_371>

AFME Response

Yes. AFME partially agrees

If trading on one venue is predominantly in only one market, it may not be appropriate for that venue to provide data disaggregated across all asset class (e.g. if there have been a couple of trades in other asset classes). The costs will outweigh the benefits.

<ESMA_QUESTION_371>

Q372: Do you believe the list of asset classes proposed in the previous paragraph is appropriate for this purpose? If not, what would you propose?

<ESMA_QUESTION_372>

AFME Response

No. AFME recommends that the fixed income should be broken out into its respective asset classes – it is not sufficiently granular.

Certain venues do provide trading across asset classes and users of information do not necessarily participate in all asset classes of fixed income. Therefore, the information would be of more value if fixed income was broken out into its respective asset classes. Also, it would mean that users that do not participate in all asset classes do not need to purchase all the information available – otherwise, it would increase cost of purchasing of the data and the cost of building infrastructure needed to analyse the data.

<ESMA_QUESTION_372>

Q373: Do you agree that venues should be under an obligation to disaggregate according to the listed criteria unless they can demonstrate that there is insufficient customer interest?

<ESMA_QUESTION_373>

AFME Response

Yes. AFME partially agrees.

We believe the same considerations outlined in answer to **DP Question 371** apply.

<ESMA_QUESTION_373>

Q374: Are there any other criteria according to which it would be useful for venues to disaggregate their data, and if so do you think there should be a mandatory or comply-or-explain requirement for them to do so?

<ESMA_QUESTION_374>

AFME Response

No. AFME does not propose any other criteria.

<ESMA_QUESTION_374>

Q375: What impact do you think greater disaggregation will have in practice for overall costs faced by customers?

<ESMA_QUESTION_375>

TYPE YOUR TEXT HERE

<ESMA_QUESTION_375>

5.6. Identification of the investment firm responsible for making public the volume and price transparency of a transaction (Articles 20(3) (c) and 21(5)(c), MiFIR)

Q376: Please describe your views about how to improve the current trade reporting system under Article 27(4) of MiFID Implementing Regulation.

<ESMA_QUESTION_376>

AFME does not agree with applying Article 27(4) of the MiFID Implementing Regulation to fixed income. As ESMA has noted, the current regime has resulted in a high level of duplication and

poor quality data. Therefore, we do not believe that it makes sense to introduce the same regime for bonds and SFPs.

We strongly suggest for there to be clear trade publication protocols in place to ensure that post trade information is not of poor quality. We suggest that this can be achieved through the following principles:

- (i) Venue trades are always published
- (ii) Investment firms apply a suppression waterfall to determine whether their trade should be published
- (iii) Investments firms can opt for their APA to apply the waterfall

Specifically, we propose the following waterfall:

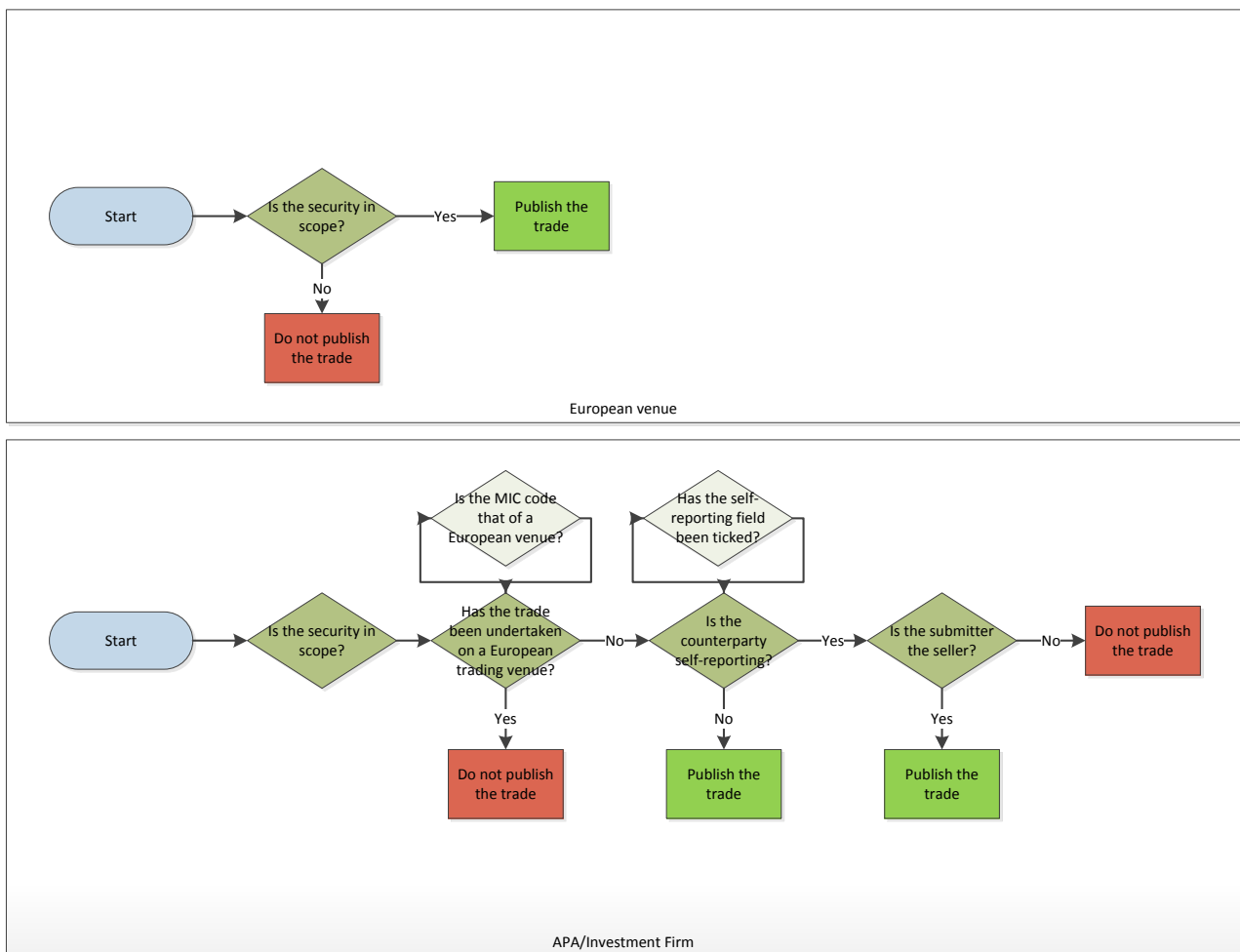

The waterfall works as follows: (i) European venues always publish their trades; and (ii) the APA receiving the information from an investment firm or the investment firm applies the following logic:

- If the trade has been undertaken on a European venue, the APA should not publish the trade/the investment firm should not submit the trade to the APA – **the trade should be suppressed**
- If the trade has not been undertaken on a European trading venue, if the counterparty of the submitting investment firm/of the investment firm is not a self-reporting entity (whether or

not a counterparty is self-reporting is bilaterally arranged and documented), then the APA should publish the trade/the investment firm should submit the trade to the APA – **the trade should be published**; and

- If the counterparty of the submitting investment firm/of the investment firm is a self-reporting entity, the APA should only publish the trade/the investment firm should only submit the trade to the APA if the investment firm is the seller

(i) Trades on venue

If a trade is executed on venue, it is essential that the trade is not published three times (by the venue and both the counterparties). We would welcome confirmation from ESMA that the trade reporting obligations on investment firms set out in Articles 20 and 21 MiFIR are not intended to apply if the relevant transaction is executed on a trading venue (which transaction would therefore be reported by the relevant trading venue in accordance with Articles 6 and 10 MiFIR).

We note that the current trade publication requirements under Article 28 MiFID are clearer in this respect than the obligations under MiFIR, although (i) the closing words of Article 20(2) and 21(4) MiFIR provide support for an interpretation that limits Articles 20 and 21 to transactions executed outside a trading venue, and (ii) Articles 20 and 21 contain provisions aimed at preventing duplication of reporting [Article 20(3)(c) and Article 21(2) and (5)(c)], which provisions would be undermined if a transaction executed on a trading venue had to be reported separately by the investment firm party to the transaction and the trading venue.

We assume that any changes in drafting to the trade publication obligation between MiFID and MiFIR were not intended to result in duplicate reporting of trades executed on a trading venue, which would be confusing to the market and national regulators alike. We would suggest that ESMA embed such a clarification in the recitals to the Regulatory Technical Standards it drafts.

(ii) Trades not undertaken on venue

Trades undertaken off-venue can also be duplicated - two firms trading with one another can both publish the trade. Therefore, rather than introducing a complex and ambiguous network of firms or APAs having to communicate and cross check against each other, we propose the simple protocol above. We suggest that an investment firm can opt for the APA to apply the waterfall rather than undertake the work in-house. We believe that this should be encouraged because it will most likely result in a more consistent application of the framework (we expect there to be fewer APAs than firms) and existing data flows can be leveraged. Therefore, the role of the APA in the application of waterfall needs to be recognised in the MiFID regime.

The protocol that we propose should result in only one APA publishing a trade. Also, we suggest that better and consistent application of the protocol can be achieved by ESMA expressly providing that investment firms fulfil their publication requirements if the APA publishes or suppresses the trade (otherwise investment firms could be encouraged to overpublish).

The application of our proposed protocol is dependent on investment firms/APAs applying the waterfall to the following data fields:

| | |
|--------------------------|--|
| <p>MIC code of venue</p> | <p>This is to identify whether the trade has already been published through a European venue. If it has, the APA/investment firm should suppress the trade publication, otherwise the same trade will be published two or three times, creating distortions in the market.</p> <p>The MIC code is the identifier code of the</p> |
|--------------------------|--|

| | |
|---|--|
| | <p>venue. Notably, only European venues are subject to the post trade publication rules; therefore, it is essential for ESMA to maintain and publish a list of all European registered trading venues together with their MIC codes to ensure that APAs and firms can identify whether the trade will already be published.</p> |
| <p>Is the counterparty to the trade self-reporting (Yes/No)</p> | <p>There will be a contractual arrangement between dealers and each of their counterparties as to whether their counterparties will delegate reporting and thereby take up a non-self-reporting status. It should be noted these are bilateral arrangements and a counterparty may choose to be self-reporting with one dealer and non-self-reporting with another.</p> <p>If the APA is applying the waterfall, it is important for firms to populate this field to identify whether two self-reporting parties will publish the trade through an APA (which may very well be different APAs). In order for a waterfall to be applied to ensure that there is no duplicative reporting, this field is essential.</p> <p>The waterfall will be such that if the counterparty is non-self-reporting, then the trade will be published. If this field is not introduced as a non-public field, it may result in firms inconsistently applying the waterfall as there is no mandated field to ensure counterparty self-reporting field is appropriately documented and populated.</p> |
| <p>Buyer/Seller</p> | <p>This field is important for, again, the application of the waterfall to ensure that there is no duplicative reporting.</p> <p>In the event that there are two self-reporting counterparties, the buyer's trade should be suppressed.</p> |

AFME also refers to its responses to DP Questions 178 and 361.

<ESMA_QUESTION_376>

5.7. Access to CCPs and trading venues (Articles 35-36, MiFIR)

Q377: Do you agree that exceeding the planned capacity of the CCP is grounds to deny access?

<ESMA_QUESTION_377>

AFME Response:

Clearly we have no desire to see a CCP overwhelmed with transactions that it cannot process or manage appropriately. There should be an orderly migration of venues to a CCP and the CCP should be transparent in its authorisation about its capacity. We would expect that the NCA would also share with fellow regulators reasons that capacity may be exceeded.

<ESMA_QUESTION_377>

Q378: How would a CCP assess that the anticipated volume of transactions would exceed its capacity planning?

<ESMA_QUESTION_378>

AFME Response:

A CCP would need to contact the trading venue to determine historical volumes, and then determine if that was within the capacity planning. This data should also be shared with the relevant NCAs.

<ESMA_QUESTION_378>

Q379: Are there other risks related to the anticipated volume of transactions that should be considered? If so, how would such risks arise from the provision of access?

<ESMA_QUESTION_379>

AFME Response:

If a CCP has suitable headroom to accommodate more transactions and has a history of clearing the relevant product type, the risks should be minimised.

<ESMA_QUESTION_379>

Q380: Do you agree that exceeding the planned capacity of the CCP is grounds to deny access?

<ESMA_QUESTION_380>

AFME Response:

The CCP should be able to demonstrate in a transparent manner why the capacity is exceeded to the trading venue and its college of regulators before denying access.

<ESMA_QUESTION_380>

Q381: How would a CCP assess that the number of users expected to access its systems would exceed its capacity planning?

<ESMA_QUESTION_381>

TYPE YOUR TEXT HERE

<ESMA_QUESTION_381>

Q382: Are there other risks related to number of users that should be considered? If so, how would such risks arise from the provision of access?

<ESMA_QUESTION_382>
TYPE YOUR TEXT HERE
<ESMA_QUESTION_382>

Q383: In what way could granting access to a trading venue expose a CCP to risks associated with a change in the type of users accessing the CCP? Are there any additional risks that could be relevant in this situation?

<ESMA_QUESTION_383>

AFME Response:

CCPs have well established criteria allowing member firms access. It should have the ability to reject a participant that applies for access as a clearing member under a new venue in the same way as it can currently. The trading member would have to find a new, acceptable clearer in order to trade.

<ESMA_QUESTION_383>

Q384: How would a CCP establish that the anticipated operational risk would exceed its operational risk management design?

<ESMA_QUESTION_384>
TYPE YOUR TEXT HERE
<ESMA_QUESTION_384>

Q385: Are there other risks related to arrangements for managing operational risk that should be considered? If so, how would such risks arise from the provision of access?

<ESMA_QUESTION_385>
TYPE YOUR TEXT HERE
<ESMA_QUESTION_385>

Q386: Given there will be costs to meeting an access request, what regard should be given to those costs that would create significant undue risk?

<ESMA_QUESTION_386>

AFME Response:

Costs may be recouped from users or the trading venue securing access or members of the CCP that benefit from such access, or both, or absorbed by the CCP and/or trading venue. We recognise that there will be an investment by a CCP and the trading venue initially, but there is the possibility to recoup this cost from members. If members are unprepared to pay, access could be denied. Evidence of significant undue risk should be demonstrated by the infrastructure to its regulator/s.

<ESMA_QUESTION_386>

Q387: To what extent could a lack of harmonization in certain areas of law constitute a relevant risk in the context of granting or denying access?

<ESMA_QUESTION_387>

AFME Response:



In the cash markets, there are CCPs taking trade feeds from various MTF platforms based in different jurisdictions. We are not persuaded that a lack of harmonization in law should lead to a denial of access.

<ESMA_QUESTION_387>

Q388: Do you agree with the risks identified above in relation to complexity and other factors creating significant undue risks?

<ESMA_QUESTION_388>

TYPE YOUR TEXT HERE

<ESMA_QUESTION_388>

Q389: Q: Are there other risks related to complexity and other factors creating significant undue risks that should be considered? If so, how would such risks arise from the provision of access?

<ESMA_QUESTION_389>

TYPE YOUR TEXT HERE

<ESMA_QUESTION_389>

Q390: Do you agree with the analysis above and the conclusion specified in the previous paragraph?

<ESMA_QUESTION_390>

AFME Response:

There is the potential for a loss of revenue for an incumbent trading venue where the CCP is in the same group structure. However, this should not be grounds to deny access.

<ESMA_QUESTION_390>

Q391: To what extent would a trading venue granting access give rise to material risks because of anticipated volume of transactions and the number of users? Can you evidence that access will materially change volumes and the number of users?

<ESMA_QUESTION_391>

AFME Response:

We cannot foresee what material risks could be generated by a rise in volumes. In the cash markets, there is no evidence of such risks arising.

<ESMA_QUESTION_391>

Q392: To what extent would a trading venue granting access give rise to material risks because of arrangements for managing operational risk?

<ESMA_QUESTION_392>

AFME Response:

Trading venues grant access in the cash markets and operational risk and there has been no evidence to support the statement.

<ESMA_QUESTION_392>

Q393: Given there will be costs to meeting an access request, what regard should be given to those costs that would create significant undue risk?



<ESMA_QUESTION_393>

AFME Response:

Costs may be recouped from users or the trading venue securing access or members of the CCP that benefit from such access, or both, or absorbed by the CCP and/or trading venue. We recognise that there will be an investment by a CCP and the trading venue initially, but there is the possibility to recoup this cost from members. If members are unprepared to pay, access could be denied. Evidence of significant undue risk should be demonstrated by the infrastructure to its regulator/s.

<ESMA_QUESTION_393>

Q394: Do you believe a CCP's model regarding the acceptance of trades may create risks to a trading venue if access is provided? If so, please explain in which cases and how.

<ESMA_QUESTION_394>

AFME Response:

Trading venues need to understand the criteria for acceptance by a CCP e.g. transactions which cannot be cleared will become bilaterally settled transactions. There will be the potential for Trading Venues and CCPs to update their rules accordingly. A difference in the ability and timings of termination could also prove problematic and so each party needs to understand and align their rules accordingly. However, in cash equity markets, we do not foresee the creation of substantial addition risk. This model is used today and it has not created the anticipated problems to date, although a great deal of work was undertaken prior to the CCPs and Trading Venues agreeing to the overall process.

<ESMA_QUESTION_394>

Q395: Could granting access create unmanageable risks for trading venues due to conflicts of law arising from the involvement of different legal regimes?

<ESMA_QUESTION_395>

AFME Response:

The laws which trading is undertaken should not present significant conflicts to those of the CCP responsible for clearing the transactions. The cash market has multiple examples of CCPs clearing on behalf of entities based in different locations. To date, this has caused no discernible risks to CCPs or Trading Venues alike.

<ESMA_QUESTION_395>

Q396: Are there other risks related to complexity and other factors creating significant undue risks that should be considered? If so, how would such risks arise from the provision of access?

<ESMA_QUESTION_396>

AFME Response:

This would require an analysis of each jurisdiction to ensure there would be no conflict between trading venues and CCPs.

<ESMA_QUESTION_396>

Q397: Do you agree with the conditions set out above? If you do not, please state why not.



<ESMA_QUESTION_397>

AFME Response:

If the conditions outlined are offered on a fair, reasonable and non discriminatory basis, and transparent to all, we would agree with the conditions set out in 35 and 36.

<ESMA_QUESTION_397>

Q398: Are there any other conditions CCPs and trading venues should include in their terms for agreeing access?

<ESMA_QUESTION_398>

TYPE YOUR TEXT HERE

<ESMA_QUESTION_398>

Q399: Are there any other fees that are relevant in the context of Articles 35 and 36 of MiFIR that should be analysed?

<ESMA_QUESTION_399>

AFME Response:

For cash markets, most CCPs publish relatively simple tariff structures which are easy to understand and enable prediction of total costs. We would support any conditions announced by ESMA that support this approach for both Trading Venues and CCPs. We agree that the same fees and rebates should apply to all CCPs accessing the same or similar products.

<ESMA_QUESTION_399>

Q400: Are there other considerations that need to be made in respect of transparent and non-discriminatory fees?

<ESMA_QUESTION_400>

AFME Response:

We are not aware of any at this stage.

<ESMA_QUESTION_400>

Q401: Do you consider that the proposed approach adequately reflects the need to ensure that the CCP does not apply discriminatory collateral requirements? What alternative approach would you consider?

<ESMA_QUESTION_401>

AFME Response:

The CCP should be comfortable that its risk model is adequately suited to calculating margin and the product sufficiently correlated before allowing access. At no stage should the CCP be prevented from assessing risk on its own terms or forced to clear a product that does not meet its risk criteria.

<ESMA_QUESTION_401>

Q402: Do you see other conditions under which netting of economically equivalent contracts would be enforceable and ensure non-discriminatory treatment for the prospective trading venue in line with all the conditions of Article 35(1)(a)?

<ESMA_QUESTION_402>



AFME Response:

This would require further legal analysis of both jurisdictions to ensure that there is no conflict. The CCP rules should always apply.

<ESMA_QUESTION_402>

Q403: The approach above relies on the CCP's model compliance with Article 27 of Regulation (EU) No 153/2013, do you see any other circumstances for a CCP to cross margin correlated contracts? Do you see other conditions under which cross margining of correlated contracts would be enforceable and ensure non-discriminatory treatment for the prospective trading venue?

<ESMA_QUESTION_403>

AFME Response:

We do see the possibility for future clearing of off-exchange transactions in the cash markets. We would expect that these trades could be cross margined with on exchange transactions. These securities should also be netted for beneficial risk management purposes.

<ESMA_QUESTION_403>

Q404: Do you agree with ESMA that the two considerations that could justify a national competent authority in denying access are (a) knowledge it has about the trading venue or CCP being at risk of not meeting its legal obligations, and (b) liquidity fragmentation? If not, please explain why.

<ESMA_QUESTION_404>

AFME Response:

We agree with point a). We are less clear how NCA would assess if member firms have access to clearing arrangements at a CCP. And if it did not, a firm could appoint a GCM to act on its behalf liquidity fragmentation may not be a factor.

<ESMA_QUESTION_404>

Q405: How could the above mentioned considerations be further specified?

<ESMA_QUESTION_405>

AFME Response:

This trading and clearing structure is common today in cash securities. Encouraging CCPs and Trading Venues to open up and provide choice is a way to reduce the systemic risk (as not all risk is concentrated in one institution) and may be a method to avoid the problems of liquidity fragmentation.

<ESMA_QUESTION_405>

Q406: Are there other conditions that may threaten the smooth and orderly functioning of the markets or adversely affect systemic risk? If so, how would such risks arise from the provision of access?

<ESMA_QUESTION_406>

TYPE YOUR TEXT HERE

<ESMA_QUESTION_406>



Q407: Do you agree with ESMA’s proposed approach that where there are equally accepted alternative approaches to calculating notional amount, but there are notable differences in the value to which these calculation methods give rise, ESMA should specify the method that should be used?

<ESMA_QUESTION_407>
TYPE YOUR TEXT HERE
<ESMA_QUESTION_407>

Q408: Do you agree that the examples provided above are appropriate for ESMA to adopt given the purpose for which the opt-out mechanism was introduced? If not, why, and what alternative(s) would you propose?

<ESMA_QUESTION_408>
TYPE YOUR TEXT HERE
<ESMA_QUESTION_408>

Q409: For which types of exchange traded derivative instruments do you consider there to be notable differences in the way the notional amount is calculated? How should the notional amount for these particular instruments be calculated?

<ESMA_QUESTION_409>
TYPE YOUR TEXT HERE
<ESMA_QUESTION_409>

Q410: Are there any other considerations ESMA should take into account when further specifying how notional amount should be calculated? In particular, how should technical transactions be treated for the purposes of Article 36(5), MiFIR?

<ESMA_QUESTION_410>
TYPE YOUR TEXT HERE
<ESMA_QUESTION_410>

5.8. Non- discriminatory access to and obligation to license benchmarks

Q411: Do you agree that trading venues require the relevant information mentioned above? If not, why?

<ESMA_QUESTION_411>
TYPE YOUR TEXT HERE
<ESMA_QUESTION_411>

Q412: Is there any other additional information in respect of price and data feeds that a trading venue would need for the purposes of trading?

<ESMA_QUESTION_412>
TYPE YOUR TEXT HERE
<ESMA_QUESTION_412>

Q413: Do you agree that CCPs require the relevant information mentioned above? If not, why?

<ESMA_QUESTION_413>
TYPE YOUR TEXT HERE
<ESMA_QUESTION_413>



Q414: Is there any other additional information in respect of price and data feeds that a CCP would need for the purposes of clearing?

<ESMA_QUESTION_414>
TYPE YOUR TEXT HERE
<ESMA_QUESTION_414>

Q415: Do you agree that trading venues should have access to benchmark values as soon as they are calculated? If not, why?

<ESMA_QUESTION_415>
TYPE YOUR TEXT HERE
<ESMA_QUESTION_415>

Q416: Do you agree that CCPs should have access to benchmark values as soon as they are calculated? If not, why?

<ESMA_QUESTION_416>
TYPE YOUR TEXT HERE
<ESMA_QUESTION_416>

Q417: Do you agree that trading venues require the relevant information mentioned above? If not, why?

<ESMA_QUESTION_417>
TYPE YOUR TEXT HERE
<ESMA_QUESTION_417>

Q418: Is there any other additional information in respect of composition that a trading venue would need for the purposes of trading?

<ESMA_QUESTION_418>
TYPE YOUR TEXT HERE
<ESMA_QUESTION_418>

Q419: Do you agree that CCPs require the relevant information mentioned above? If not, why?

<ESMA_QUESTION_419>
TYPE YOUR TEXT HERE
<ESMA_QUESTION_419>

Q420: Is there any other additional information in respect of composition that a CCP would need for the purposes of clearing?

<ESMA_QUESTION_420>
TYPE YOUR TEXT HERE
<ESMA_QUESTION_420>

Q421: Do you agree that trading venues and CCPs should be notified of any planned changes to the composition of the benchmark in advance? And that where this is not possible, notification should be given as soon as the change is made? If not, why?

<ESMA_QUESTION_421>
TYPE YOUR TEXT HERE
<ESMA_QUESTION_421>



Q422: Do you agree that trading venues need the relevant information mentioned above? If not, why?

<ESMA_QUESTION_422>
TYPE YOUR TEXT HERE
<ESMA_QUESTION_422>

Q423: Is there any other additional information in respect of methodology that a trading venue would need for the purposes of trading?

<ESMA_QUESTION_423>
TYPE YOUR TEXT HERE
<ESMA_QUESTION_423>

Q424: Do you agree that CCPs require the relevant information mentioned above? If not, why?

<ESMA_QUESTION_424>
TYPE YOUR TEXT HERE
<ESMA_QUESTION_424>

Q425: Is there any other additional information in respect of methodology that a CCP would need for the purposes of clearing?

<ESMA_QUESTION_425>
TYPE YOUR TEXT HERE
<ESMA_QUESTION_425>

Q426: Is there any information in respect of the methodology of a benchmark that a person with proprietary rights to a benchmark should not be required to provide to a trading venue or a CCP?

<ESMA_QUESTION_426>
TYPE YOUR TEXT HERE
<ESMA_QUESTION_426>

Q427: Do you agree that trading venues require the relevant information mentioned above (values, types and sources of inputs, used to develop benchmark values)? If not, why?

<ESMA_QUESTION_427>
TYPE YOUR TEXT HERE
<ESMA_QUESTION_427>

Q428: Is there any other additional information in respect of pricing that a trading venue would need for the purposes of trading?

<ESMA_QUESTION_428>
TYPE YOUR TEXT HERE
<ESMA_QUESTION_428>

Q429: In what other circumstances should a trading venue not be able to require the values of the constituents of a benchmark?

<ESMA_QUESTION_429>
TYPE YOUR TEXT HERE
<ESMA_QUESTION_429>



Q430: Do you agree that CCPs require the relevant information mentioned above? If not, why?

<ESMA_QUESTION_430>
TYPE YOUR TEXT HERE
<ESMA_QUESTION_430>

Q431: Is there any other additional information in respect of pricing that a CCP would need for the purposes of clearing?

<ESMA_QUESTION_431>
TYPE YOUR TEXT HERE
<ESMA_QUESTION_431>

Q432: In what other circumstances should a CCP not be able to require the values of the constituents of a benchmark?

<ESMA_QUESTION_432>
TYPE YOUR TEXT HERE
<ESMA_QUESTION_432>

Q433: Do you agree that trading venues require the additional information mentioned above? If not, why?

<ESMA_QUESTION_433>
TYPE YOUR TEXT HERE
<ESMA_QUESTION_433>

Q434: Do you agree that CCPs require the additional information mentioned above? If not, why?

<ESMA_QUESTION_434>
TYPE YOUR TEXT HERE
<ESMA_QUESTION_434>

Q435: Is there any other information that a trading venue would need for the purposes of trading?

<ESMA_QUESTION_435>
TYPE YOUR TEXT HERE
<ESMA_QUESTION_435>

Q436: Is there any other information that a CCP would need for the purposes of clearing?

<ESMA_QUESTION_436>
TYPE YOUR TEXT HERE
<ESMA_QUESTION_436>

Q437: Do you agree with the principles described above? If not, why?

<ESMA_QUESTION_437>
TYPE YOUR TEXT HERE
<ESMA_QUESTION_437>

Q438: Do users of trading venues need non-publicly disclosed information on benchmarks?

<ESMA_QUESTION_438>



TYPE YOUR TEXT HERE
<ESMA_QUESTION_438>

Q439: Do users of CCPs need non-publicly disclosed information on benchmarks?

<ESMA_QUESTION_439>
TYPE YOUR TEXT HERE
<ESMA_QUESTION_439>

Q440: Where information is not available publicly should users be provided with the relevant information through agreements with the person with proprietary rights to the benchmark or with its trading venue / CCP?

<ESMA_QUESTION_440>
TYPE YOUR TEXT HERE
<ESMA_QUESTION_440>

Q441: Do you agree with the conditions set out above? If not, please state why not.

<ESMA_QUESTION_441>
TYPE YOUR TEXT HERE
<ESMA_QUESTION_441>

Q442: Are there any other conditions persons with proprietary rights to a benchmark and trading venues should include in their terms for agreeing access?

<ESMA_QUESTION_442>
TYPE YOUR TEXT HERE
<ESMA_QUESTION_442>

Q443: Are there any other conditions persons with proprietary rights to a benchmark and CCPs should include in their terms for agreeing access?

<ESMA_QUESTION_443>
TYPE YOUR TEXT HERE
<ESMA_QUESTION_443>

Q444: Which specific terms/conditions currently included in licensing agreements might be discriminatory/give rise to preventing access?

<ESMA_QUESTION_444>
TYPE YOUR TEXT HERE
<ESMA_QUESTION_444>

Q445: Do you have views on how termination should be handled in relation to outstanding/significant cases of breach?

<ESMA_QUESTION_445>
TYPE YOUR TEXT HERE
<ESMA_QUESTION_445>

Q446: Do you agree with the approach ESMA has taken regarding the assessment of a benchmark's novelty, i.e., to balance/weight certain factors against one another? If not, how do you think the assessment should be carried out?

<ESMA_QUESTION_446>
TYPE YOUR TEXT HERE



<ESMA_QUESTION_446>

Q447: Do you agree that each newly released series of a benchmark should not be considered a new benchmark?

<ESMA_QUESTION_447>

TYPE YOUR TEXT HERE

<ESMA_QUESTION_447>

Q448: Do you agree that the factors mentioned above could be considered when assessing whether a benchmark is new? If not, why?

<ESMA_QUESTION_448>

TYPE YOUR TEXT HERE

<ESMA_QUESTION_448>

Q449: Are there any factors that would determine that a benchmark is not new?

<ESMA_QUESTION_449>

TYPE YOUR TEXT HERE

<ESMA_QUESTION_449>

6. Requirements applying on and to trading venues

6.1. Admission to Trading

Q450: What are your views regarding the conditions that have to be satisfied in order for a financial instrument to be admitted to trading?

<ESMA_QUESTION_450>

AFME Response

AFME seeks clarification as to the definition and meaning of ‘admitted to trading’ in this instance.

<ESMA_QUESTION_450>

Q451: In your experience, do you consider that the requirements being in place since 2007 have worked satisfactorily or do they require updating? If the latter, which additional requirements should be imposed?

<ESMA_QUESTION_451>

TYPE YOUR TEXT HERE

<ESMA_QUESTION_451>

Q452: More specifically, do you think that the requirements for transferable securities, units in collective investment undertakings and/or derivatives need to be amended or updated? What is your proposal?

<ESMA_QUESTION_452>

TYPE YOUR TEXT HERE

<ESMA_QUESTION_452>

Q453: How do you assess the proposal in respect of requiring ETFs to offer market making arrangements and direct redemption facilities at least in cases where the regulated market value of units or shares significantly varies from the net asset value?

<ESMA_QUESTION_453>

TYPE YOUR TEXT HERE

<ESMA_QUESTION_453>

Q454: Which arrangements are currently in place at European markets to verify compliance of issuers with initial, on-going and ad hoc disclosure obligations?

<ESMA_QUESTION_454>

TYPE YOUR TEXT HERE

<ESMA_QUESTION_454>

Q455: What are your experiences in respect of such arrangements?

<ESMA_QUESTION_455>

TYPE YOUR TEXT HERE

<ESMA_QUESTION_455>

Q456: What is your view on how effective these arrangements are in performing verification checks?

<ESMA_QUESTION_456>
TYPE YOUR TEXT HERE
<ESMA_QUESTION_456>

Q457: What arrangements are currently in place on European regulated markets to facilitate access of members or participants to information being made public under Union law?

<ESMA_QUESTION_457>
TYPE YOUR TEXT HERE
<ESMA_QUESTION_457>

Q458: What are your experiences in respect of such arrangements?

<ESMA_QUESTION_458>
TYPE YOUR TEXT HERE
<ESMA_QUESTION_458>

Q459: How do you assess the effectiveness of these arrangements in achieving their goals?

<ESMA_QUESTION_459>
TYPE YOUR TEXT HERE
<ESMA_QUESTION_459>

Q460: Do you agree with that, for the purpose of Article 51 (3) (2) of MiFID II, the arrangements for facilitating access to information shall encompass the Prospectus, Transparency and Market Abuse Directives (in the future the Market Abuse Regulation)? Do you consider that this should also include MiFIR trade transparency obligations?

<ESMA_QUESTION_460>
TYPE YOUR TEXT HERE
<ESMA_QUESTION_460>

6.2. Suspension and Removal of Financial Instruments from Trading - connection between a derivative and the underlying financial instrument and standards for determining formats and timings of communications and publications

Q461: Do you agree with the specifications outlined above for the suspension or removal from trading of derivatives which are related to financial instruments that are suspended or removed?

<ESMA_QUESTION_461>
TYPE YOUR TEXT HERE
<ESMA_QUESTION_461>

Q462: Do you think that any derivatives with indices or a basket of financial instruments as an underlying the pricing of which depends on multiple price inputs should be suspended if one or more of the instruments composing the index or the basket are suspended on the basis that they are sufficiently related? If so, what methodology would you propose for determining whether they are “sufficiently related”? Please explain.

<ESMA_QUESTION_462>
TYPE YOUR TEXT HERE
<ESMA_QUESTION_462>

Q463: Do you agree with the principles outlined above for the timing and format of communications and publications to be effected by trading venue operators?

<ESMA_QUESTION_463>

AFME Response

AFME would seek that the decision to be made is done so in a prompt and efficient manner. It may be sufficient if it were to be communicated immediately on a website if this can be relied upon.

<ESMA_QUESTION_463>

7. Commodity derivatives

7.1. Ancillary Activity

Q464: Do you see any difficulties in defining the term 'group' as proposed above?

<ESMA_QUESTION_464>

AFME Response

We agree with ESMA's analysis regarding the definitions of "group", "parent undertaking" and "subsidiary" under MiFID II, and the conclusion that the term "group" comprises the parent undertaking and all its subsidiary undertakings, where subsidiary undertakings include undertakings controlled by a parent undertaking in accordance with Article 22 of Directive 2013/34/EU.

The circumstances in which a parent undertaking would be considered to have "control" under Article 22 of Directive 2013/34/EU are already used in other directives and there is already an understanding on how these terms should be interpreted, so we consider that it is appropriate to refer to these circumstances in the definition of "group" (and also that this is consistent with the definitions set out in MiFID II).

<ESMA_QUESTION_464>

Q465: What are the advantages and disadvantages of the two alternative approaches mentioned above (taking into account non-EU activities versus taking into account only EU activities of a group)? Please provide reasons for your answer.

<ESMA_QUESTION_465>

AFME Response

We consider that the term "group" should be interpreted as meaning the global group, including non-EU entities within the group, and that the consolidated financial statements of a parent undertaking is correctly identified by ESMA as being a key reference in defining how a "group" is constituted.

However, it is critical that the definition of "group" in MiFID II is consistent with the definition under EMIR to ensure that non-EU activities are captured and that there is consistency between the two regimes.

Recital 21 of MiFID II makes it clear that the group definition under MiFID II should be read consistently with that under EMIR, as otherwise consistency in the interpretation of "intra-group transactions" would not be possible (it would not be consistent to look at the activities of the EU subsidiaries only under MiFID II, while excluding transactions entered into with members of the broader consolidation group in accordance with the "intra-group transactions carve-out under EMIR). Recital 40 EMIR makes it clear that the definition of "group" under EMIR covers groups which are consolidated in accordance with non-EU consolidation requirements.

<ESMA_QUESTION_465>

Q466: What are the main challenges in relation to both approaches and how could they be addressed?

<ESMA_QUESTION_466>

AFME Response

As noted by ESMA, an EU-only approach has the potential for creating loopholes.

A possible disadvantage of the world-wide approach is the difficulty to assess the world-wide market size due to lack of available data.

<ESMA_QUESTION_466>

Q467: Do you consider there are any difficulties concerning the suggested approach for assessing whether the ancillary activities constitute a minority of activities at group level? Do you consider that the proposed calculations appropriately factor in activity which is subject to the permitted exemptions under Article 2(4) MiFID II? If no, please explain why and provide an alternative proposal.

<ESMA_QUESTION_467>

AFME Response

Although we appreciate that a quantitative approach may be more objective, we consider that the better approach would be to assess whether or not activities are "ancillary activities" by reference to a combination of qualitative and quantitative criteria. MiFID II clearly requires an approach based on more than just quantitative criteria. Article 2(4) states that the relevant criteria shall **take into account at least** whether an activity constitutes a minority of activities at group level, and goes on to state that the capital employed **shall in no case be sufficient** to demonstrate that the activity is ancillary to the main business of the group.

In addition, for activities to qualify as "ancillary activities" they should be truly ancillary to the main business (i.e., they should complement and provide necessary support to the main business). A business line which is merely incidental to or wholly unrelated to the main business of the group should not be considered to be "ancillary to the main business".

We consider that an approach based only on quantitative criteria is likely to lead to anomalous results. For example, in the context of a global group, 49% of the group's activities could constitute a significant business line relative to the main business of the group and may even give the group a dominant position in that business activity in some jurisdictions, but using only quantitative criteria such as the formulae proposed this business line would be considered to constitute ancillary activities.

However, if qualitative criteria are employed in combination with quantitative criteria then such qualitative tests could easily identify that the relevant business line is not "ancillary" and is in fact wholly unrelated to the main business.

However, if ESMA intends to apply quantitative criteria alongside qualitative criteria (or instead of qualitative criteria) we consider that a 50% threshold is too high. We discuss this further in our response to Q469.

Regarding the proposed calculations, we consider that the denominator should reflect the capital employed for the main activity at group level (calculated by deducting the capital employed for the sum of ancillary activities from the capital for the remaining activity as calculated in accordance with paragraph 24 of section 7 of the DP), as proposed by ESMA. We agree that the proposed calculations do appropriately factor in activity which is subject to the permitted exemptions under Article 2(4) MiFID II.

We do not consider that the denominator should reflect the capital for overall activity at group level, as this would not appropriately factor in activity which is subject to the permitted exemptions under Article 2(4) MiFID II.

<ESMA_QUESTION_467>

Q468: Are there other approaches for assessing whether the ancillary activities constitute a minority of activities at group level that you would like to suggest? Please provide details and reasons.

<ESMA_QUESTION_468>

AFME Response

As mentioned in our response to Q467, we consider that the better approach would be to assess whether or not activities are "ancillary activities" by reference to qualitative criteria (or by reference to a combination of qualitative and quantitative criteria). Examples of qualitative factors which ESMA could take into account compared to authorised entities and the entity's main business, include:

- Market presence in the relevant activity;
- VaR used in the relevant activity;
- Compensation structure (e.g. do employees work to sales targets or receive bonuses based on level of business generated);
- Headcount;
- Whether or not the entity is a member of relevant exchanges or other trading venues.

<ESMA_QUESTION_468>

Q469: How should "minority of activities" be defined? Should minority be less than 50% or less (50 - x)%? Please provide reasons.

<ESMA_QUESTION_469>

AFME Response

As mentioned in our responses to Q467 and Q468, we consider that the better approach would be to assess whether or not activities are "ancillary activities" by reference to qualitative criteria (or by reference to a combination of qualitative and quantitative criteria). We appreciate that quantitative criteria can give a more objectively measurable result, but consider that where this test needs to be applied to a wide range of different businesses (in terms of their size, geographical scope and nature of their activities) it should not be a simple one-size fits all metric but will need to be more sophisticated.

However, if ESMA ultimately decides to apply quantitative criteria alongside qualitative criteria (or instead of qualitative criteria) we consider that a 50% threshold is too high and that "minority of activities" should be defined as a much lower percentage of a group's main business activity to ensure that any ancillary activities do fairly represent a minority of activities at group level. If the threshold is set at 50% or less we consider that this would still permit entities to carry on a significant amount of "MiFID business" without being subject to regulation.

If a 50% threshold was applied alongside other qualitative criteria this may reduce the risk of anomalous results somewhat. However, we still consider that while less than 50% may technically constitute a minority, it does not necessarily follow that a business line which makes up 49% of an entity's business should be considered to be an ancillary activity and could (relative to

the main business of the group) constitute a significant amount of "MiFID business" which would be unregulated.

For example, in the context of a global group, 49% (or even a significantly lower figure, such as 20%) of the group's activities could constitute a significant business line and may even give the group a dominant position in that business in some jurisdictions.

In addition, if you look at the business lines operated by an entity, the relevant activity might be the largest single business line at 49% of the total business, while other business lines are individually far smaller even if taken together they comprise 51% of the total business.

If ESMA does decide to use quantitative criteria, we consider that a significantly lower threshold would be appropriate, in conjunction with other qualitative criteria. We would suggest a threshold in the region of 10 – 15%.

<ESMA_QUESTION_469>

Q470: Do you have a view on whether economic or accounting capital should be used in order to define the elements triggering the exemption from authorisation under MiFID II, available under Article 2(1)(j)? Please provide reasons.

<ESMA_QUESTION_470>

AFME Response

In order to provide a fully informed view on whether economic or accounting capital should be used, ESMA should provide more detailed information on what it means by accounting and economic capital.

We consider that ESMA should adopt an approach which does not only rely on a single metric in order to determine availability of the exemption. For example, ESMA could adopt an approach using accounting capital together with some economic capital metrics, measured against both the activity of the entity and that of the wider market such as:

- Headcount;
- Balance sheet usage / revenue / working capital employed;
- VaR used in the relevant activity;
- Compensation structure.

ESMA would need to establish a standard formula for calculating each of these metrics.

ESMA has indicated in the DP that where an accounting capital measure is not available, an economic capital measure should be used. If ESMA intends to take this approach (or to allow economic capital measures to be used), it would be useful to have a clear indication of what is meant by accounting and economic capital so that it is clear how these measures should be calculated, the specific heads of economic capital which ESMA considers to be relevant and measurable and instances when accounting capital may not be available. In order to avoid creating loopholes it should not be possible for entities to cherry-pick which approach they wish to use, based on the approach which gives them the best outcome.

<ESMA_QUESTION_470>

Q471: If economic capital were to be used as a measure, what do you understand to be encompassed by this term?

<ESMA_QUESTION_471>

AFME Response

As stated above, using economic capital as a measure would need further clarity from regulators as economic capital typically uses a variety of stress test methodology in its calculation and tends to be based on differing proprietary risk evaluation models and will vary across activities between the trading and non-trading parts of the business.

<ESMA_QUESTION_471>

Q472: Do you agree with the above assessment that the data available in the TRs will enable entities to perform the necessary calculations?

<ESMA_QUESTION_472>

AFME Response

We do not believe that Trade Repositories will contain the data to assess trading activity.

<ESMA_QUESTION_472>

Q473: What difficulties do you consider entities may encounter in obtaining the information that is necessary to define the size of their own trading activity and the size of the overall market trading activity from TRs? How could the identified difficulties be addressed?

<ESMA_QUESTION_473>

AFME Response

Firms assess their overall trading activity and reconcile their daily positions using their own internal risk and back office systems. It is not foreseen that firms will use TRs to assess or reconcile their trading activity. In addition TRs cannot provide a picture of overall EU and non-EU market activity given that under EMIR non-EU counterparties are not obliged to report their transactions.

<ESMA_QUESTION_473>

Q474: What do you consider to be the difficulties in defining the volume of the transactions entered into to fulfil liquidity obligations?

<ESMA_QUESTION_474>

AFME Response

The "requirement" to fulfil liquidity obligations should be a clearly stated and defined regulatory obligation, whether the obligation is satisfied directly against counterparties or through a trading venue.

Commercial liquidity arrangements between venues and their participants should be explicitly excluded by ESMA, as these arrangements are entered into voluntarily by participants in return for commercial benefits and not purely in order to satisfy a regulatory requirement.

<ESMA_QUESTION_474>

Q475: How should the volume of the overall trading activity of the firm at group level and the volume of the transactions entered into in order to hedge physical activities be measured? (Number of contracts or nominal value? Period of time to be considered?)

<ESMA_QUESTION_475>

AFME Response

We consider that since the hedging provision is intended to be considered in a way that is consistent with Regulation (EU) No 648/2012 (as mentioned in Recital 21 to MiFID II), the volume of transactions entered into to hedge commercial activities should be measured in the same way as under EMIR. This would mean that firms should look at the gross notional value of the relevant contracts.

<ESMA_QUESTION_475>

Q476: Do you agree with the level of granularity of asset classes suggested in order to provide for relative comparison between market participants?

<ESMA_QUESTION_476>

AFME Response

We are sympathetic to the argument that these asset classes should not be too granular given that by exceeding a threshold in one asset class, a firm would automatically trigger a MiFID II obligation in all asset classes. We note that in the Energy asset class it is much easier to exceed a trading threshold in gas than in oil, due to nominal contract size, even though volume of trading may be much smaller in gas.

However, we consider that grouping together a number of related asset classes may lead to arbitrary outcomes and may not fulfil the intention expressed by ESMA in paragraph 1 of section 7 of the DP, "to provide for a more narrow interpretation of allowed exempt activities thereby capturing within the scope of MiFID II a range of firms previously excluded".

<ESMA_QUESTION_476>

Q477: What difficulties could there be regarding the aggregation of TR data in order to obtain information on the size of the overall market trading activity? How could these difficulties be addressed?

<ESMA_QUESTION_477>

AFME Response

Given that only EU entities are subject to reporting derivative trades to a TR under EMIR, a large part of the commodity derivative market which is traded by non-EU entities bi-laterally and/or on markets external to the EU would not be reportable. Therefore there would be no way of incorporating these non-EU transactions into the overall market trading activity data held in European TRs.

In addition regulators need to be clear on what type of information they need to determine overall trading activity and for what purpose. If it is for systemic risk purposes, we suggest that position data is the correct data to show overall market share. This is problematic particularly for ETD trades under EMIR, as there is no obligation to report position data.

<ESMA_QUESTION_477>

Q478: How should ESMA set the threshold above which persons fall within MiFID II's scope? At what percentage should the threshold be set? Please provide reasons for your response.

<ESMA_QUESTION_478>

AFME Response

ESMA should assess the size of overall market trading activity in each relevant asset class, and set a threshold that is appropriate for that asset class. These thresholds should be kept under

periodic review to ensure that they remain appropriate for the size of overall market trading activity in the relevant asset class. We consider that the threshold should be set at a relatively low level to ensure that activities exempt from regulation under MiFID are truly ancillary when compared to the main business of the group.

ESMA's comments in paragraph 38 of section 7 of the DP indicate that persons seeking to rely on this exemption may need to determine the size of overall trading activity in the different asset classes themselves. We consider that in order to ensure that all persons relying on the exemption are using the same approach to calculating the size of overall trading activity, ESMA should either publish detailed guidance on this calculation, or should publish indicative figures for overall trading activity which must be used in determining whether or not the exemption applies.

In particular, ESMA should consider leveraging the preliminary quantitative analysis (and any subsequent, more detailed analysis) that it has carried out in respect of the thresholds for assessing whether or not a firm should qualify as a systematic internaliser (discussed in section 3.3 of ESMA's CP), as well as the work that it has carried out in respect of position limits (discussed in section 7.2 of ESMA's DP).

ESMA should also ensure that when obtaining information from market participants it obtains information from unregulated market participants as well as from investment firms.

We note that in relation to establishing the size of relevant markets under the position limits regime ESMA has noted that this poses significant challenges. The same is also true for the definition of ancillary activities.

<ESMA_QUESTION_478>

Q479: Are there other approaches for determining the size of the trading activity that you would like to suggest?

<ESMA_QUESTION_479>

AFME Response

We suggest that position reports to be submitted under Art 58.1 could be a better measure for assessing trading activity than trade data reports from TRs. The only positions missing from such reports would be the pure bilateral trades (i.e. not traded on a RM, MTF or OTF).

<ESMA_QUESTION_479>

Q480: Are there other elements apart from the need for ancillary activities to constitute a minority of activities and the comparison between the size of the trading activity and size of the overall market trading activity that ESMA should take into account when defining whether an activity is ancillary to the main business?

<ESMA_QUESTION_480>

AFME Response

We agree that other qualitative elements should be taken into account when determining whether or not an activity is ancillary to the main business (see our responses to Q468 and Q470) and we support the view that ESMA should take into account how closely related a person's activities are to the main business. If the activity is integral to the main business it should not be regarded as ancillary (e.g., if a trading house is trading for its own account as its main business). Similarly, an activity should not be regarded as ancillary if it is determined to be merely incidental or secondary to a person's main business.



As set out in our response to Q468, qualitative elements that ESMA should take into account compared to authorised entities and the entity's main business include:

- Market presence in the relevant activity;
- VaR used in the relevant activity;
- Compensation structure (e.g. do employees work to sales targets or receive bonuses based on level of business generated);
- Headcount;
- Whether or not the entity is a member of relevant exchanges or other trading venues.

<ESMA_QUESTION_480>

Q481: Do you see any difficulties with the interpretation of the hedging exemptions mentioned above under Article 2(4)(a) and (c) of MiFID II? How could potential difficulties be addressed?

<ESMA_QUESTION_481>

AFME Response

In general we support the interpretation of the hedging exemptions under Article 2 (4) (a) and (c) of MiFID II and believe that Article 3 of EMIR is appropriate. However we suggest that full reference to the relevant definition of the hedging exemption as defined in EMIR is made in the Regulatory Technical Standards in MiFID II.

<ESMA_QUESTION_481>

Q482: Do you agree with ESMA's proposal to take into account Article 10 of the Commission Delegated Regulation (EU) No 149/2013 supplementing EMIR in specifying the application of the hedging exemption under Article 2(4)(b) of MiFID II? How could any potential difficulties be addressed?

<ESMA_QUESTION_482>

AFME Response

We support that Article 10 of the Commission Delegated Regulation (EU) No 149/2013 supplementing EMIR should be taken into account in relation to transactions objectively mitigating risks relating to commercial or treasury financing activity. However, the response to question 10(c) on portfolio hedging in the related ESMA Q&A states that there must be sufficient disaggregation in order to establish a clear link between the types of contracts entered into and the commercial or treasury activity of the group. Commercial firms use complex hedging instruments across many geographies, markets, products and time horizons to reduce firm wide risk on an overall aggregate basis. Consequently we believe that disaggregating portions of this overall risk reducing activity may result in increased risks and hedging costs resulting in higher pass-through costs to consumers.

We would draw attention to ESMA that regulators in other jurisdictions such as Canada have provided guidance that there will be situations where a commercial firm may qualify for the hedging exemption even where some of the trades in a portfolio could be interpreted as not being a hedge, as long as there is a reasonable commercial basis to conclude that such trades are included in the commercial firm's wider portfolio as part of its overall risk mitigation strategy.

<ESMA_QUESTION_482>

Q483: Do you agree that the obligations to provide liquidity under Article 17(3) and Article 57(8)(d) of MiFID II should not be taken into account as an obligation triggering the hedging exemption mentioned above under Article 2(4)(c)?

<ESMA_QUESTION_483>

AFME Response

We agree that the obligations to provide liquidity under Article 17(3) and Article 57(8)(d) should not be taken into account as an obligation which is carved out under Article 2(4)(c), for the reasons given by ESMA in the DP.

<ESMA_QUESTION_483>

Q484: Could you provide any other specific examples of obligations of “transactions in commodity derivatives and emission allowances entered into to fulfil obligations to provide liquidity on a trading venue” which ESMA should take into account?

<ESMA_QUESTION_484>

AFME Response

As set out in our response to Q474, the "requirement" to fulfil liquidity obligations should be a clearly stated and defined regulatory obligation, whether the obligation is satisfied directly against counterparties or through a trading venue.

Commercial liquidity arrangements between venues and their participants should be explicitly excluded by ESMA, as these arrangements are entered into voluntarily by participants in return for commercial benefits and not purely in order to satisfy a regulatory requirement.

As a result, ESMA should take into account requirements to provide liquidity imposed by national competent authorities, and should obtain information on the relevant requirements from those national competent authorities.

<ESMA_QUESTION_484>

Q485: Should the (timeframe for) assessment be linked to audit processes?

<ESMA_QUESTION_485>

AFME Response

Yes. This should be an annual review signed off by auditors. The burden and cost to comply should fall on those companies looking to make use of the exemptions.

<ESMA_QUESTION_485>

Q486: How should seasonal variations be taken into account (for instance, if a firm puts on a maximum position at one point in the year and sells that down through the following twelve months should the calculation be taken at the maximum point or on average)?

<ESMA_QUESTION_486>

AFME Response

Seasonal variations should be adequately captured if the calculation is made on an average trade basis, over a minimum period of 12 months.

ESMA should retain the right to re-assess this basis to address any spikes that might appear in particular businesses.

<ESMA_QUESTION_486>

Q487: Which approach would be practical in relation to firms that may fall within the scope of MiFID in one year but qualify for exemption in another year?

<ESMA_QUESTION_487>

AFME Response

We believe that firms should be assessed on a 3 year rolling average of their trading activity reported to regulators on an annual basis. We believe that trading activity data should be based on continual assessment throughout 12 months of the year and not based on a single snapshot at a given time. If a firm falls into MiFID II on this basis then a minimum 12 month transition period should be given to enable the firm to take the necessary operational steps to implement MiFID.

<ESMA_QUESTION_487>

Q488: Do you see difficulties with regard to the two approaches suggested above?

<ESMA_QUESTION_488>

AFME Response

We do not have a strong position on this point so long as the status of the relevant entity is clear to the market at any given time.

<ESMA_QUESTION_488>

Q489: How could a possible interim approach be defined with regard to the suggestion mentioned above (i.e. annual notification but calculation on a three years rolling basis)?

<ESMA_QUESTION_489>

AFME Response

We do not have a strong position on this point so long as the status of the relevant entity is clear to the market at any given time.

<ESMA_QUESTION_489>

Q490: Do you agree that the competent authority to which the notification has to be made should be the one of the place of incorporation?

<ESMA_QUESTION_490>

AFME Response

Yes, we agree that the competent authority in the place of incorporation of the entity invoking the (j) exemption should be notified should it be required. This is consistent with regulatory supervisory regimes already in place at a national level throughout the EU.

<ESMA_QUESTION_490>

7.2. Position Limits

Q491: Do you agree with ESMA's proposal to link the definition of a risk-reducing trade under MiFID II to the definition applicable under EMIR? If you do not agree, what alternative definition do you believe is appropriate?



<ESMA_QUESTION_491>

AFME Response

Regarding OTC contracts, we agree that hedges excluded from the position limits regime should remain consistent with hedges excluded from the clearing threshold under EMIR and, therefore, agree that the definition of risk reducing trade under MiFID II should be the same as under EMIR, i.e. article 10(3) of EMIR and article 10 of the EMIR regulatory technical standards (EU N° 149/2013).

We also think that, since position limits is a tool for maintaining orderly markets, the exemption should also cover trades on exchange and not just OTC. We note that the primary purpose of EMIR is risk mitigation and central clearing of OTC derivatives and that for this reason on-venue contracts are not covered. MIFID aims to apply to both on-venue and OTFC contracts.

<ESMA_QUESTION_491>

Q492: Do you agree with ESMA's proposed definition of a non-financial entity? If you do not agree, what alternative definition do you believe is appropriate?

<ESMA_QUESTION_492>

AFME Response

We agree that the definition of non-financial entity (NFE) under the MiFID II position limits regime should be aligned with the definition of non-financial counterparty (NFC) under article 2(9) of EMIR, which excludes entities which must obtain licence under existing European financial services legislation as set out in the definition of 'financial counterparty' under article 2(8) of EMIR (i.e. investment firms, credit institutions, insurance companies, UCITS and their asset management companies, AIFs and their management companies, pension funds).

However, we note with concern ESMA's proposal in paragraph 14 that MiFID II would use the existing comparable definition within EMIR of non-financial counterparty. The definition of NFE does not currently appear to consider application to third country entities. A third country credit institution with no presence in the EU will not be required to seek authorisation under the Banking Directive, and so under the current definition would qualify as a NFE. For the purpose of alignment with the EMIR NFC concept, the definition should be amended to cover entities established in the EU which are not required to seek authorisation under the relevant directives, and entities established outside the EU which would not have been required to seek authorization if they had been established in the EU.

We also note that if the definitions of economically equivalent OTC contracts and of netting are not sufficiently broad, an entity that may be required to be licensed under MiFID II (and which therefore would no longer be an NFE) will not be able to rely on the hedging exemption to the position limits regime and that this prohibition will materially limit its ability to manage the risks associated with its commercial activities effectively.

<ESMA_QUESTION_492>

Q493: Should the regime for subsidiaries of a person other than entities that are wholly owned look to aggregate on the basis of a discrete percentage threshold or on a more subjective basis? What are the advantages and risks of either approach? Do you agree with the proposal that where the positions of an entity that is subject to substantial control by a person are aggregated, they are included in their entirety?

<ESMA_QUESTION_493>

AFME Response

In principle, we agree that the notion of control should be the basis of the proposed regime for aggregation of group positions and support the view that provided controlled undertakings can demonstrate through objective criteria that they operate independently from their parent company, they should be able to disaggregate.

On disaggregation, we particularly agree with the statement of ESMA that aggregation with fellow subsidiaries of a mutual parent or ultimate holding company should not be required.

We also call for the development of other exemptions from aggregation for: (1) certain limited partners, shareholders or other commodity pool participants; (2) accounts held by investment firms, brokers, and similar market intermediaries; (3) accounts carried by an independent account controller; (4) positions held in connection with underwriting activity or a broker-dealer acquired in the normal course of business; and (5) information sharing where prohibited by law or regulation.

In the draft RTS dated 20 March 2014 under the revised Transparency Directive (2013/50/EU amending 2004/109/EC) - for the purpose of shareholdings calculation notably through derivatives - ESMA proposes that the parent undertaking of an entity wishing to benefit from the exemption in relation to holdings sets a list of the effectively controlled entities with their competent authorities and a statement that these controlled entities do not receive any direct or indirect instructions from the parent undertaking in the exercise of the voting rights. In addition, we understand that the exemption applies to non-EU groups and non-EU controlled undertakings where it can be demonstrated that the relevant undertaking's market making and trading activities as well as its asset management activities meet the independence criteria on an on-going basis as set out in the draft RTS under the Transparency Directive.

Although the purpose of the Transparency Directive is different from the MiFID position limits regime (exercise of voting rights versus positions on commodities), we believe that the definitions of the aggregation of positions at a group level should be aligned. We however do not support that any ownership percentage between 50% and 100% automatically involves aggregation of positions between the parent undertaking and the subsidiary without any consideration to independence in investment strategies or trading businesses.

<ESMA_QUESTION_493>

Q494: Should the regime apply to the positions held by unconnected persons where they are acting together with a common purpose (for example, “concert party” arrangements where different market participants collude to act for common purpose)?

<ESMA_QUESTION_494>

AFME Response

In principle, we support rules aiming at tracking 'concert parties'.

We note that the Level 1 text sets out in article 57(12) of MiFID II that ESMA is required to draft RTS only in respect of limited circumstances. Specifically with respect to aggregation, it is required to draft “*the methods to determine when positions of a person are to be aggregated within a group*”.

As this notion of ‘concert parties’ is not referenced in article 57(12), ESMA may not be able to introduce level 2 measures on this point. In any case, if ESMA was to introduce such rules, we would support alignment with principles that were enforced under the legislative texts that already use this concept. We also believe that “*the circumstances where it is appropriate to*

aggregate positions even for unconnected persons where they are tied together in a common purpose" (page 409 of the Discussion paper, Paragraph 20) must be proved by the competent authority in charge of enforcing the position limits regime.

<ESMA_QUESTION_494>

Q495: Do you agree with the approach to link the definition of economically equivalent OTC contract, for the purpose of position limits, with the definitions used in other parts of MiFID II? If you do not agree, what alternative definition do you believe is appropriate?

<ESMA_QUESTION_495>

AFME Response

Position limits apply to commodity derivatives contracts covered by the MiFID II definition of financial instruments (as stated in article 57 as well as recitals 127, 130 and 131).

However to accurately reflect the net risk-exposure of market participants, underlying physical positions, including non-derivative contracts, should be taken into account.

With this in mind, we highlight the following points:

- ESMA should set a list of EU listed contracts subject to the limits in order to bring legal certainty to the scope of the position limits regime.
- It is essential that written contracts from different locations should have the same notion of equivalence to ensure that the commodity risk exposures are accurately reflected. Since position limits will apply to net positions, netting must be allowed also between underlying physical (non-derivative) contracts and the on-venue contract subject to the position limits.
- ESMA should not impose an artificial restriction on the ability to net cash-settled and physically-settled non-derivative contracts if the contracts are economically equivalent. The level 1 text accurately sets that the economic equivalence is in the heart of the calculation of a position and not a legal equivalence. The purpose of level 1, clearly stated in article 57.1 (a), is to 'prevent market abuse' and 'support orderly pricing and settlement conditions'. These objectives go with a definition of netting that reflects the reality of these global markets.
- The industry strongly supports a mechanism that is sufficiently broad and legally clear (i.e. measurable). In this respect we believe that the first approach is not sufficiently broad because the criteria are cumulative. We also think that the implementation in the European Union of the second approach would need to be tailored to meet a much broader pool of contracts rather than the list of 28 contracts but potentially to all on-venue contracts. But we believe that the second approach offers a more practicable set of equivalence criteria by setting out the specific types of contracts which could be considered to be equivalent and that this type of approach would facilitate implementation. We suggest that ESMA considers defining qualitative criteria (which may be the same for certain commodities) per asset class, i.e. a) Oil, b) Gas and power, c) Metals, d) Agriculture.
- We note with concern that ESMA's comments in the Discussion Paper indicate that it intends to interpret economically equivalent OTC contracts as meaning only MiFID financial instruments. In order to ensure a workable netting regime, market participants

should be allowed to net against the underlying physical positions, including contracts that are not commodity derivatives (e.g., certain REMIT instruments and other physical contracts, e.g. coal and oil, or spot contracts). This greater pooling of positions and the provision of netting to allow bona fide hedges to be offset against physically settled transactions would therefore facilitate the accurate presentation of commodity risk levels.

- In addition, a wider definition along the lines noted above is consistent with how the market hedges physical transactions which generally do not qualify as MiFID financial instruments (for example, (i) physically delivered metal forwards and options not traded on an MTF, not being for commercial purposes or having characteristics of other derivative financial instruments are hedged with LME futures; (ii) wholesale energy products subject to the REMIT carve out are hedged with power futures on European power exchanges; and (iii) OTC physically settled Loco London good delivery gold can be hedged with COMEX (non-EU venue) futures).
- Also, we encourage ESMA to consider the need for “proxy hedging” when considering economically equivalent OTC contracts. Proxy hedging occurs when a risk related to a particular product is managed by hedging with a different product. For example, a participant may choose to hedge jet fuel exposure with ICE Europe Gas Oil Futures Contracts, since this ICE futures contract is both a key price determinant in European jet fuel markets and a highly liquid risk management tool. For the market to function as efficiently as possible and for all participants to have the ability to continue to offer, and benefit from, price risk management services, the position limit regime should allow for netting between proxy hedging contracts as economically equivalent contracts.

We recognise that there are challenges in defining proxy hedging contracts and in this regard refer ESMA to the CME Group rules and guidance on Exchange for Related Position (EFRP) transactions. EFRP’s are used by market participants to establish, move or liquidate exchange positions by executing the exchange product versus an OTC contract. There are several types of EFRPs, including an Exchange of Futures for Physical (EFP), which is defined as, “*the simultaneous execution of an Exchange futures contract and a corresponding physical transaction or a forward contract on a physical transaction.*” In determining what may qualify for the physical component of the EFP the CME Group provides the following in its guidance (see link provided):

“The related position component of the EFRP must involve the product underlying the Exchange contract or a by-product, related product or OTC derivative instrument that is reasonably correlated to the corresponding Exchange instrument.

The related position component of an EFRP may not be a futures contract or an option on a futures contract.

Where the risk characteristics and/or maturities of the related position differ from the instrument underlying the Exchange contract, the parties to the EFRP may be required to demonstrate the correlation between the products and the methodology used in equating the futures to the related position. In all cases, the related position transaction must be comparable with respect to quantity, value or risk exposure of the corresponding Exchange contract.”

<http://www.cmegroup.com/tools-information/lookups/advisories/market-regulation/files/RA1311-5.pdf>

The CME Group rules and guidance highlight both the need for proxy hedging capabilities and a general level of accepted market practice. ESMA requests suggested amendments to the second approach to determining economically equivalent OTC contracts (see Q497). We suggest that the CME Group rules and guidance on EFP transactions could be considered as the basis of an additional proxy hedging criterion for economically equivalent OTC contracts under the second approach.

<ESMA_QUESTION_495>

Q496: Do you agree that even where a contract is, or may be, cash-settled it is appropriate to base its equivalence on the substitutability of the underlying physical commodity that it is referenced to? If you do not agree, what alternative measures of equivalence could be used?

<ESMA_QUESTION_496>

AFME Response

We generally agree that it would be appropriate to base equivalence on the substitutability of the underlying commodity for such contracts. This is consistent with the legislative text in MiFID II which calls for a determination of *economic* equivalence. We emphasise that there must be genuine *economic* substitutability, i.e. fungibility, between cash-settled and physical-delivery contracts. Netting across cash-settled and physical delivery contracts is critical as segregating cash settled and physically delivered contracts could fragment the market and could push liquidity towards fewer markets.

<ESMA_QUESTION_496>

Q497: Do you believe that the definition of “economically equivalent” that is used by the CFTC is appropriate for the purpose of defining the contracts that are not traded on a trading venue for the position limits regime of MiFID II? Give reasons to support your views as well as any suggested amendments or additions to this definition.

<ESMA_QUESTION_497>

AFME Response

See our response to question 495:

“Position limits apply to commodity derivatives contracts covered by the MiFID II definition of financial instruments (as stated in article 57 as well as recitals 127, 130 and 131).

However to accurately reflect the net risk-exposure of market participants, underlying physical positions, including non-derivative contracts, should be taken into account.

With this in mind, we highlight the following points:

- ESMA should set a list of EU listed contracts subject to the limits in order to bring legal certainty to the scope of the position limits regime.
- It is essential that written contracts from different location should have the same notion of equivalence to ensure that the commodity risk exposures are accurately reflected. Since position limits will apply to net positions, netting must be allowed also between underlying physical (non-derivative) contracts and the on-venue contract subject to the position limits.

- ESMA should not impose an artificial restriction on the ability to net cash-settled and physically-settled non-derivative contracts if the contracts are economically equivalent. The level 1 text accurately sets that the economic equivalence is in the heart of the calculation of a position and not a legal equivalence. The purpose of level 1, clearly stated in article 57.1 (a), is to ‘prevent market abuse’ and ‘support orderly pricing and settlement conditions’. These objectives go with a definition of netting that reflects the reality of these global markets.
- The industry strongly supports a mechanism that is sufficiently broad and legally clear (i.e. measurable). In this respect we believe that the first approach is not sufficiently broad because the criteria are cumulative. We also think that the implementation in the European Union of the second approach would need to be tailored to meet a much broader pool of contracts rather than the list of 28 contracts but potentially to all on-venue contracts. But we believe that the second approach offers a more practicable set of equivalence criteria by setting out the specific types of contracts which could be considered to be equivalent and that this type of approach would facilitate implementation. We suggest that ESMA considers defining qualitative criteria (which may be the same for certain commodities) per asset class, i.e. a) Oil, b) Gas and power, c) Metals, d) Agriculture.
- We note from ESMA’s comments in the Discussion Paper that it intends to interpret economically equivalent OTC contracts as meaning only MiFID financial instruments. In order to ensure a workable netting regime, market participants should be allowed to net against the underlying physical positions, including contracts that are not commodity derivatives (e.g., certain REMIT instruments and other physical contracts, e.g. coal and oil, or spot contracts). This greater pooling of positions and the provision of netting to allow bona fide hedges to be offset against physically settled transactions would therefore facilitate the accurate presentation of commodity risk levels.
- In addition, a wider definition along the lines noted above is consistent with how the market hedges physical transactions which generally do not qualify as MiFID financial instruments (for example, (i) physically delivered metal forwards and options not traded on an MTF, not being for commercial purposes or having characteristics of other derivative financial instruments are hedged with LME futures; (ii) wholesale energy products subject to the REMIT carve out are hedged with power futures on European power exchanges; and (iii) OTC physically settled Loco London good delivery gold can be hedged with COMEX (non-EU venue) futures).
- Also, we encourage ESMA to consider the need for “proxy hedging” when considering economically equivalent OTC contracts. Proxy hedging occurs when a risk related to a particular product is managed by hedging with a different product. For example, a participant may choose to hedge jet fuel exposure with ICE Europe Gas Oil Futures Contracts, since this ICE futures contract is both a key price determinant in European jet fuel markets and a highly liquid risk management tool. For the market to function as efficiently as possible and for all participants to have the ability to continue to offer, and benefit from, price risk management services, the position limit regime should allow for netting between proxy hedging contracts as economically equivalent contracts.

We recognise that there are challenges in defining proxy hedging contracts and in this regard refer ESMA to the CME Group rules and guidance on Exchange for Related Position (EFRP) transactions. EFRP’s are used by market participants to establish, move or liquidate exchange positions by executing the exchange product versus an OTC contract.

There are several types of EFRPs, including an Exchange of Futures for Physical (EFP), which is defined as, “*the simultaneous execution of an Exchange futures contract and a corresponding physical transaction or a forward contract on a physical transaction.*” In determining what may qualify for the physical component of the EFP the CME Group provides the following in its guidance (see link provided):

“The related position component of the EFRP must involve the product underlying the Exchange contract or a by-product, related product or OTC derivative instrument that is reasonably correlated to the corresponding Exchange instrument.

The related position component of an EFRP may not be a futures contract or an option on a futures contract.

Where the risk characteristics and/or maturities of the related position differ from the instrument underlying the Exchange contract, the parties to the EFRP may be required to demonstrate the correlation between the products and the methodology used in equating the futures to the related position. In all cases, the related position transaction must be comparable with respect to quantity, value or risk exposure of the corresponding Exchange contract.”

<http://www.cmegroup.com/tools-information/lookups/advisories/market-regulation/files/RA1311-5.pdf>

The CME Group rules and guidance highlight both the need for proxy hedging capabilities and a general level of accepted market practice. ESMA requests suggested amendments to the second approach to determining economically equivalent OTC contracts (see Q497). We suggest that the CME Group rules and guidance on EFP transactions could be considered as the basis of an additional proxy hedging criterion for economically equivalent OTC contracts under the second approach.

In addition, we would like to highlight that the CME Group rules and guidance highlight both the need for proxy hedging capabilities and a general level of accepted market practice. In response to ESMA’s request for amendments to the second approach to determining economically equivalent OTC contracts, we suggest that the CME Group rules and guidance on EFP transactions could be considered as the basis of an additional proxy hedging criterion for economically equivalent OTC contracts under the second approach.

We generally support this second approach as it is aligned more closely to the idea that limits should apply to the commodity risk levels and the economics of the underlying positions. It is also consistent with CFTC rules which will facilitate implementation for the many market participants that operate on both the EU and the US. We believe that the CFTC definition is appropriate for contracts that are not traded on a trading venue for the position limits regime of MiFID II, subject to ESMA recognising a wide definition of economically equivalent as highlighted in our response to question 495. Alignment of the two definitions would ensure global regulatory consistency in a global market. The definitions provide a logical sub-set of contracts to ensure that the resulting application of position limits would meet the European Parliament and Council’s aims of preventing market abuse and supporting orderly pricing. A consistent approach across jurisdictions also greatly reduces the complexity of systems and controls required by global firms subject to both the CFTC and EU regimes.

We also reiterate that if ESMA’s intention is to limit the definition of economically equivalent OTC contracts to MiFID II financial instruments, it is not clear whether broad netting (to accurately reflect commodity risk levels) can be achieved.



<ESMA_QUESTION_497>

Q498: What arrangements could be put in place to support competent authorities identifying what OTC contracts are considered to be economically equivalent to listed contracts traded on a trading venue? ?

<ESMA_QUESTION_498>

AFME Response

Once the definition of economically equivalent OTC contracts is set with sufficient width and certainty, then the implementation and supervision will be much easier. We therefore believe that the response to this question largely depends upon the definition of economically equivalent OTC contracts. We also believe that CCPs and trading venues will be essential in conveying the necessary data for determining economically equivalent positions to listed contracts. Competent authorities may consider publishing examples of what they consider to be economically equivalent OTC contracts by commodity asset class as this would facilitate consistent interpretation and implementation (based on qualitative criteria par asset class). The lists would not be exhaustive but would aim to provide guidance.

<ESMA_QUESTION_498>

Q499: Do you agree with ESMA’s proposal that the “same” derivative contract occurs where an identical contract is listed independently on two or more different trading venues? What other alternative definitions of “same” could be applied to commodity derivatives?

<ESMA_QUESTION_499>

AFME Response

The intention of article 57(6) of MiFID II is to apply a single position limit across multiple trading venues where “the same” contract is traded. However, as a practical matter, we question if ESMA will be able to monitor and to resolve disputes with respect to position limits, in respect of trading venues located outside the EU. The example used in paragraph 35, page 412, of the discussion paper, is of the KOSPI 200 contract traded on Eurex and the Korea Exchange, is helpful however we do not see how the German regulator could impose its own position limits on the South Korean trading venue where there is no such regime.

We agree that the 'same' derivative contract is a subset of economically equivalent contract and that in addition to the criteria for recognising economically equivalent contracts, other elements have to be taken into account such as the settlement process.

We also strongly believe that the concept of ‘same contract’ is to be used only for the purpose of article 57(6) and shall not be used for the purpose of netting and calculation of net positions aggregated at a group level.

<ESMA_QUESTION_499>

Q500: Do you agree with ESMA’s proposals on aggregation and netting? How should ESMA address the practical obstacles to including within the assessment positions entered into OTC or on third country venues? Should ESMA adopt a model for pooling related contracts and should this extend to closely correlated contracts? How should equivalent contracts be converted into a similar metric to the exchange traded contract they are deemed equivalent to?

<ESMA_QUESTION_500>

AFME Response

On aggregation of contracts (for aggregation at a group level, please see our response to question 493), we agree that same contracts and OTC economically equivalent contracts should be included within the calculation. When facilitating client trades where there is limited liquidity in the specific underlying contract,

investment firms use hedging strategies across many geographies, markets, products and time horizons to manage their residual risk. The regime should allow for this approach.

On netting, we consider that the calculation of a market participant's position should be with respect to its net position on a portfolio basis for identical or correlated commodities (e.g. gasoil / oil, power / emissions) across different commodity markets and on third country venues (if considered significant for EU markets for example, COMEX or WTI) in order to accurately represent commodity risk levels.

Naturally, we would caution against any extra-territorial application of EU position limits to contracts on third country venues; this would not be supported by the level 1 text and, practically speaking, if implemented could lead to conflicting rules and requirements applying to the same position.

With respect to cross-commodity hedges, we recommend that ESMA reviews and takes into account the CFTC rules for cross-commodity hedges including quantitative (i.e. setting of correlation limits) and qualitative (i.e. commercial relationship between target commodity and commodity underlying the derivative contract) factors. We note, however, that ESMA should not impose a rigid quantitative test for determining what constitutes a permissible cross-commodity hedge e.g. a specific correlation requirement. While this may seem an attractive policy option it has major limitations due to the fact that many commodity markets do not have liquid exchange-traded derivatives that can be used as a hedge. In such cases, market participants must hedge their risk using related derivatives products even though these hedges are not perfect i.e. ICE's Brent Contract is used to hedge a significant number of energy commodities. A qualitative test that is based on specific facts and circumstances and defers to the reasonable judgment of market participants is most appropriate.

<ESMA_QUESTION_500>

Q501: Do you agree with ESMA's approach to defining market size for physically settled contracts? Is it appropriate for cash settled contracts to set position limits without taking into account the underlying physical market?

<ESMA_QUESTION_501>

AFME Response

Deliverable supply is the right metric for physically settled spot month contracts. For cash settled spot-month contracts, we believe that the metric should be the open interest.

We also believe that although they are expressed as percentage of open interest, limits on cash-settled spot month contracts should be as aligned as possible with limits applied to physically-settled spot month contracts.

In relation to the use of open interests for limits on physical and cash settled non-spot month contracts, as the MiFID II regime applies to a broader range of commodity derivatives than just futures and will include economically equivalent OTC contracts, it will be necessary to adjust the open interests (given is a futures related metric) to add the notional volumes of swaps relating to the relevant on-venue contract. It is also the case that certain commodities may not have a related futures contract and competent authorities will need to estimate the open interests based on notional amounts of swaps.

We also call ESMA to provide further detail on how they intend to determine the overall market size for securities contracts with a commodity underlying.

We highlight that there are significant implementation issues that need to be considered further. In particular: (i) the definition of deliverable supply/open interest and (ii) ensuring that the deliverable supply/open interest is based on reliable, accurate and current information. For example:

For ICE Europe Brent crude oil futures contract "...is a deliverable contract based on EFP delivery with an option to cash settle against the ICE Brent Index price for the last trading day of the futures contract. The Exchange shall publish a cash settlement price (the ICE Brent Index price) on the next trading day following the last trading day for the contract month"

This ICE Europe futures example highlights the difficulty in determining deliverable supply for a particular contract as effectively any crude oil can form the basis of an EFP transaction for the purposes of settling

the ICE Europe Brent crude oil futures contract. This example also highlights the difficulty in sourcing reliable, accurate and current data to determine deliverable supply.

Also, the difference between commodities means that some are durable and can be stored indefinitely and some cannot; this means that for some commodities as well as production deliverable supply should also include stock levels (i.e. surplus production stored from a prior period).

We note, even though question 501 does not address this issue, that in this section the discussion paper addresses the notification and approval of exemptions (paragraph 43, page 413). It is very unclear how such mechanism should work in practice without being burdensome and potentially disruptive of markets and hedging conditions. For the sake of effective and smooth implementation and supervision, we strongly support a notification process that works on the basis of assumption that the exemption is approved until and unless is explicitly rejected. In other words: market participants shall notify the competent authority before breaching the position limit; the notification should be based on a web service; the exemptions shall be considered as accepted by until and unless is explicitly rejected. Upon rejection, the market participant is required to reduce its positions in a reasonable timeframe. This solution would allow markets to continue to hedge their commercial exposure whilst mitigating the burden and potentially adverse consequences of the approval procedure.

<ESMA_QUESTION_501>

Q502: Do you agree that it is preferable to set the position limit on a contract for a fixed (excluding exceptional circumstances) period rather than amending it on a real-time basis? What period do you believe is appropriate, considering in particular the factors of market evolution and operational efficiency?

<ESMA_QUESTION_502>

AFME Response

We agree that amending the position limit on a real-time basis is not only unnecessarily but unfeasible and that setting it for a fixed (excluding exceptional circumstances) period is preferable. With regard to the period itself, we propose that position limits on a contract are fixed for an initial period of two years and with annual reviews thereafter with amendments to the limits only where necessary.

We also believe that spot month limits generally should not be determined at the time a contract month becomes the spot month. Determining a position limit for the spot month contract on the first day that such contract is available for trade is impractical as it would require notice of a limit to be provided when that contract has already commenced trading (open interest calculations are usually published after trading has begun each day) and when parties may already be holding positions that are in breach of that new position limit. Requiring parties to trade out of positions to comply with the new position limits may lead to artificial volatility and a disorderly market.

For instance, the LME have daily Prompt date contracts and thus have daily settlements. The LME already impose a pseudo position limit when the contract is coming up to prompt (settlement) in that it has a rule that stipulates that if the accumulated net long positions of a particular participant or member, two days before settlement, exceeds 50% of LME warranted stock, the long position holder(s) has to reduce the positions to below 50% of LME stock at a pre-determined set premium (price). It is possible to have a forward position that adds up to more than 100% of LME warranted stock. It is then up to the position holder to manage his positions over the two day period before settlement to ensure it is holding less than 50% of LME stock. LME stock figures are published each day at 09:00 UK time. We believe this is the method enshrined in the LME Lending Guidance rules that LME has been operating since 1998 is an effective tool in ensuring orderly markets and in effect imposes a pseudo position limit on LME contracts that are physically settled on the exchange. An explanation of the Lending Guidance can be found here: http://www.lme.com/~media/Files/Notices/2011/2011_10/11_293_A286_R008_Explanation_of_Meta_l_Lending_Guidance.pdf

The implementation of a position limits regime will significantly affect the functioning of the commodity markets and for this reason an initial two year period is necessary to ensure that orderly trading conditions are maintained during the transition.

The measure of the deliverable supply for a period of time is challenging and ESMA and national regulators should rely on data gathered by exchanges and on existing database aiming to ensure transparency in physical markets. A one-size fits all approach such as the "three months expiry cycle" as proposed by ESMA may not fit the fundamentals of certain commodity markets.

We also highlight that data used for the purpose of defining the deliverable supply period per commodity type should span over a period of a minimum of three years and should have a granular view on a monthly basis. When calculating the deliverable supply period per commodity type, different factors must be included, among which, a basic taxonomy (i.e.: storable versus non-storable), weather, supply chain optimization level, demand and offer curve, geographical location-distance, seasonality, growth, and market concentration, as well as the trading cycles per each commodity market. As there would be differences across commodities and that some factors are outside of the control of either of the parties to the physically-settled contract, a +/- margin should be added to the averaged/estimated delivery supply period. This +/- margin could be set at no less than 15% of the overall delivery supply period.

<ESMA_QUESTION_502>

Q503: Once the position limits regime is implemented, what period do you feel is appropriate to give sufficient notice to persons of the subsequent adjustment of position limits?

<ESMA_QUESTION_503>

AFME Response

It may depend on the underlying commodity and on the liquidity of the affected physical and financial markets.

The period must be sufficient to ensure that the adjustment does not disrupt the market. Many commodity derivatives markets are by nature illiquid. If the period is too short, then the sudden adjustment that a major market participant might need to make could create stressed conditions in the concerned market.

We support that the notice/adjustment period should be at least half the time of the fixed period however if grandfathering is allowed then a 3 to 6 month adjustment period should be manageable.

<ESMA_QUESTION_503>

Q504: Should positions based on contracts entered into before the revision of position limits be grandfathered and if so how?

<ESMA_QUESTION_504>

AFME Response

Yes, we strongly support grandfathering of contracts entered into before the revision of position limits. The immediate application of new stringent rules can adversely impact illiquid markets. Many commodity derivatives markets are illiquid by nature and the immediate application of limits to existing contracts may increase the disruption of the markets and create the conditions for higher volatility and price spikes which is exactly what the position limits regime aims to prevent or mitigate.

We also believe that staged compliance could be implemented following revision of position limits to ensure that market disruption is minimised.

<ESMA_QUESTION_504>

Q505: Do you agree with ESMA's proposals for the determination of a central or primary trading venue for the purpose of establishing position limits in the same derivative contracts? If you do not agree, what practical alternative method should be used?



<ESMA_QUESTION_505>

AFME Response

Yes. We agree that the application of the rule should be limited to the same commodity derivatives contract that is traded on two or more trading venues within the EU.

We agree with the method proposed by ESMA to assess whether the contract is traded in significant volumes in another jurisdiction. We also agree that the measure of the largest volume of trading shall be based on the largest volume of open interests measured in the number of lots of the relevant contracts.

Lastly, we reiterate that the concept of ‘same contract’ is to be used only for the purpose of article 57(6) and shall not be used for the purpose of netting and calculation of net positions aggregated at a group level.

<ESMA_QUESTION_505>

Q506: Should the level of “significant volume” be set at a different level to that proposed above? If yes, please explain what level should be applied, and how it may be determined on an ongoing basis?

<ESMA_QUESTION_506>

AFME Response

No. We agree with the approach proposed by ESMA. We obviously recognise that the revision of the measure of the 'significant volume' should be subject to the same principles as the revision of the position limits itself.

(see our response to question 502:

We agree that amending the position limit on a real-time basis is not only unnecessarily but unfeasible and that setting it for a fixed (excluding exceptional circumstances) period is preferable. With regard to the period itself, we propose that position limits on a contract are fixed for an initial period of two years and with annual reviews thereafter with amendments to the limits only where necessary.

We also believe that spot month limits generally should not be determined at the time a contract month becomes the spot month. Determining a position limit for the spot month contract on the first day that such contract is available for trade is impractical as it would require notice of a limit to be provided when that contract has already commenced trading (open interest calculations are usually published after trading has begun each day) and when parties may already be holding positions that are in breach of that new position limit. Requiring parties to trade out of positions to comply with the new position limits may lead to artificial volatility and a disorderly market.

For instance, the LME have daily Prompt date contracts and thus have daily settlements. The LME already impose a pseudo position limit when the contract is coming up to prompt (settlement) in that it has a rule that stipulates that if the accumulated net long positions of a particular participant or member, two days before settlement, exceeds 50% of LME warranted stock, the long position holder(s) has to reduce the positions to below 50% of LME stock at a pre-determined set premium (price). It is possible to have a forward position that adds up to more than 100% of LME warranted stock. It is then up to the position holder to manage his positions over the two day period before settlement to ensure it is holding less than 50% of LME stock. LME stock figures are published each day at 09:00 UK time. We believe this is the method enshrined in the LME Lending Guidance rules that LME has been operating since 1998 is an effective tool in ensuring orderly markets and in effect imposes a pseudo position limit on LME



contracts that are physically settled on the exchange. An explanation of the Lending Guidance can be found here: http://www.lme.com/~media/Files/Notices/2011/2011_10/11_293_A286_R008_Explanation_of_Metal_Lending_Guidance.pdf

The implementation of a position limits regime will significantly affect the functioning of the commodity markets and for this reason an initial two year period is necessary to ensure that orderly trading conditions are maintained during the transition.

The measure of the deliverable supply for a period of time is challenging and ESMA and national regulators should rely on data gathered by exchanges and on existing database aiming to ensure transparency in physical markets. A one-size fits all approach such as the "three months expiry cycle" as proposed by ESMA may not fit the fundamentals of certain commodity markets.

We also highlight that data used for the purpose of defining the deliverable supply period per commodity type should span over a period of a minimum of three years and should have a granular view on a monthly basis. When calculating the deliverable supply period per commodity type, different factors must be included, among which, a basic taxonomy (i.e.: storable versus non-storable), weather, supply chain optimization level, demand and offer curve, geographical location-distance, seasonality, growth, and market concentration, as well as the trading cycles per each commodity market. As there would be differences across commodities and that some factors are outside of the control of either of the parties to the physically-settled contract, a +/- margin should be added to the averaged/estimated delivery supply period. This +/- margin could be set at no less than 15% of the overall delivery supply period).

<ESMA_QUESTION_506>

Q507: In using the maturity of commodity contracts as a factor, do you agree that competent authorities apply the methodology in a different way for the spot month and for the aggregate of all other months along the curve?

<ESMA_QUESTION_507>

AFME Response

We fully agree that competent authorities apply the methodology in a different way for the spot month and to all other months along the curve, considered in aggregate. We highlight that not all commodity markets follow the same vanilla date structure. For instance, the LME does not have a spot month, e.g. for the Primary Aluminium contract there exists daily prompt dates out to 3 months, weekly: 3 out to 6 months and then Monthly : 7 out to 123 months. (The 3rd Wednesday being the monthly prompt).

Therefore we believe that ESMA should clarify how to interpret the definition of spot month when taking into account markets with daily prompts.

<ESMA_QUESTION_507>

Q508: What factors do you believe should be applied to reflect the differences in the nature of trading activity between the spot month and the forward months?

<ESMA_QUESTION_508>

AFME Response

Financial markets are structured to achieve price convergence between physical and financial commodity markets, and for futures markets to act as effective risk hedging venues for physical commodities. Settlement prices typically converge with physical market prices at expiry.

'Spot' or 'delivery' month limits restrict how many contracts a participant can hold in the period during which delivery of the physical commodity is to be made. This is where dominant market positions can have the most acute effect.

For instance, LME key metal contracts have daily prompt dates and daily settlement. Copper and Aluminium contracts go out to 10 years. A squeeze can only happen near the time of settlement when LME warrants have to be sourced in order to prepare for delivery. Further out the curve for contracts that are for further forward prompt dates have little impact on settlement and position limits are less relevant.

Further down the curve however, position limits may be less effective given reduced liquidity for long-dated contracts. If a market participant holds a large position further 'down the curve' markets have sufficient time to react. Therefore, in our view the main focus of the position limit regime should be on the spot month and to the extent that limits need to be applied to other months they should be sufficient to allow the normal functioning of the market and not unnecessarily restrict liquidity.

We also believe that it is important to take account of contract design and related specifications in addition to deliverable supply. Market distortions do not simply arise due to the size of the position built by a market participant in a particular commodity but also can arise due to the manner in which a contract is designed.

In certain cases, using deliverable supply alone as the single determining factor when setting a position limit for a commodity is insufficient as it is also necessary to take into account specific characteristics of that commodity, for example, logistical constraints i.e. ease with which the commodity can be delivered or extracted given contract delivery points.

<ESMA_QUESTION_508>

Q509: Do you agree with ESMA's proposal for trading venues to provide data on the deliverable supply underlying their contracts? If you do not agree, what considerations should be given to determining the deliverable supply for a contract?

<ESMA_QUESTION_509>

AFME Response

Yes, we fully agree that in the first instance the competent authority of the jurisdiction where a trading venue is located should obtain and use the data on deliverable supply that is maintained by that trading venue.

However, we consider that the competent authority should adjust the level of the deliverable supply as stated by the trading venue in order to reflect some other factors such as industry research or governmental statistics where it is difficult to get an accurate measure of the supply or for global markets. Also, for gas and power markets where system operators exist, the ENT-SOs should be considered, either directly or through the intermediation of trading venues.

Further where a contract is a key benchmark and is used as a proxy hedge for other commodities e.g. ICE Gasoil contract is used to hedge jet derivatives, then the position limit regime should reflect this wider market.

This is because the exchange's view of deliverable supply will be focused on the specifics of its contract, whereas the MiFID position limit regime covers a wider universe.

We also fully support the G20 initiatives aiming to enhance the transparency in physical commodity markets (production and storage) though we highlight that on some commodities (pre-

cious metals and rare earths for instance) such a transparency does not yet exist, primarily because of the reluctance of some countries in a dominant position to publish relevant data on a regular basis.

<ESMA_QUESTION_509>

Q510: In the light of the fact that some commodity markets are truly global, do you consider that open interest in similar or identical contracts in non-EEA jurisdictions should be taken into account? If so, how do you propose doing this, given that data from some trading venues may not be available on the same basis or in the same timeframe as that from other trading venues?

<ESMA_QUESTION_510>

AFME Response

Yes, we believe that a harmonised regime globally for key economically-linked contracts both exchange traded and OTC is critically needed where the fundamentals of the underlying commodity markets are global. It would be a grave concern if a global commodity such as, for instance, gold, which is traded on different markets, to have different position limits depending on whether it falls within the CFTC regulation or the EU MiFID regime.

Coordination between relevant EU and non-EU competent authorities having access to regional or national trade repositories is essential to measure the overall size of the relevant commodity derivatives markets. In other words, open interest in similar or identical contracts in non-EU jurisdictions should be taken into account. Imposing limits that do not reflect the global nature of commodity markets would cause substantial fragmentation and would be detrimental to beneficial risk management activities.

<ESMA_QUESTION_510>

Q511: In the absence of published or easily obtained information on volatility in derivative and physical commodity markets, in what ways should ESMA reflect this factor in its methodology? Are there any alternative measures that may be obtained by ESMA for use in the methodology?

<ESMA_QUESTION_511>

AFME Response

We in general believe that volatility is not a relevant criterion for the purpose of the calculation methodology of limits and we do not clearly see at this time how ESMA proposes to incorporate volatility into position limit calculations.

Volatility is natural to markets and reflects the market adjusting to new information. If regulators believe that the effect is driven by some sort of abuse they have sufficient powers under MAR to take action. We do not believe that position limits prevent volatility. There is evidence that in some cases limits may even lead to increased volatility if they are inappropriately calibrated.

The presence of volatility in a market generally leads participants to seek risk management solutions and any restriction on participants' ability to do so through the use of position limits may prohibit participants from effectively managing their risks. Further, where limits are revised down at short notice in response to increasing volatility, this may further exacerbate volatility as participants are forced to close down positions to meet the new limits. Historically, regulated markets have used margin methodologies to manage volatility. Parties unable to maintain positions in volatile markets may have to reduce positions due to margin call, but there is no artificial constraint in their ability to participate.

We therefore request ESMA to undertake a further review of the impact of volatility before including any volatility based adjustment factor in the position limit methodology.

At the very least ESMA should clarify whether volatility in this particular context is intended to refer to price volatility or to the amount of the commodity available in the market.

We agree that the absence of accurate data on all physical markets makes it difficult to measure volatility of these markets. Given that volatility usually results from a lack of liquidity, we believe that position limits should be set high enough to take into account volatility of the physical markets and the consequences that volatility has on trading volumes e.g. fewer new market participants the higher the volatility.

<ESMA_QUESTION_511>

Q512: Are there any other considerations related to the number and size of market participants that ESMA should consider in its methodology?

<ESMA_QUESTION_512>

AFME Response

We agree with ESMA's views on the size and number of market participants and do not see any other consideration. We also support ESMA's statement on page 419, paragraph 77 of the discussion paper: "*Concentration of positions in a market will particularly be a factor in national gas and power markets, which may need to set limits to reflect the existence of 'national champions', depending on the extent of fragmentation of former state-owned incumbents and the terms of any market maker schemes operated by venues as necessary for proper market operation. This is accommodated in the use of separate factors for different asset classes, which can reflect the individual market structures*".

We also believe that where a product is traded by a small number of participants, ESMA should seek to understand the composition of market participants before determining the position limit. For example, a market with ten active participants may have two sellers and eight buyers, or just one risk management provider amongst nine participants seeking risk management services. In such markets, a single position limit may have a disproportionate impact on some of the participants.

<ESMA_QUESTION_512>

Q513: Are there any other considerations related to the characteristics of the underlying commodity market that ESMA should consider in its methodology?

<ESMA_QUESTION_513>

AFME Response

We agree with ESMA's views that the seasonal supply outages in the physical market, the perishability of deliverable materials and the capacity constraints (with regard to transportation and delivery) should be taken into account. We reiterate that the absence of accurate data on production and storage of some commodities should be reflected in the consideration related to the characteristics of the underlying commodity market.

<ESMA_QUESTION_513>

Q514: For new contracts, what approach should ESMA take in establishing a regime that facilitates continued market evolution within the framework of Article 57?



<ESMA_QUESTION_514>

AFME Response

Firstly, we recognise there will be difficulty in determining position limits for new contracts. We therefore encourage ESMA to consider mechanisms to ensure that the limits do not damage developing liquidity in the new contracts. Low liquidity is not only a characteristic of new contracts, but also of many more regional or specialised commodity products. Where very few market participants exist with respect to a contract, liquidity will naturally be limited. Any consideration and/or methodology adopted for new contracts should therefore be extended to existing illiquid contracts.

We believe that the best approach would be to take each new or illiquid contract separately and consider a reasonable multiple of the current transaction size after a defined period of trading, so approach 1.

We also think that, instead of position limits, ESMA should consider relying on the position management powers available to national regulators and trading venues. New contracts often are illiquid/ immature initially and may be used by a small number of market participants. In order to accommodate the demand of hedgers and develop a robust, established market, it may be necessary to permit a small number of market participants to represent a relatively large share of the (small) market. Concerns regarding market abuse can be adequately addressed through enhanced reporting and surveillance, as necessary.

<ESMA_QUESTION_514>

Q515: The interpretation of the factors in the paragraphs above will be significant in applying ESMA's methodology; do you agree with ESMA's interpretation? If you do not agree with ESMA's interpretation, what aspects require amendment?

<ESMA_QUESTION_515>

We broadly agree with ESMA's views on the various factors that should be taken into account in the calculation methodology. We however reiterate that volatility is probably not a relevant tool for this purpose.

<ESMA_QUESTION_515>

Q516: Are there any other factors which should be included in the methodology for determining position limits? If so, state in which way (with reference to the proposed methodology explained below) they should be incorporated.

<ESMA_QUESTION_516>

Where a liquid benchmark contract is used as a proxy or a generic hedge for a range of contracts, the position limits should be set at a level to allow this bona fide hedging activity to continue.

<ESMA_QUESTION_516>

Q517: What do you consider to be the risks and/or the advantages of applying a different methodology for determining position limits for prompt reference contracts compared to the methodology used for the position limit on forward maturities?

<ESMA_QUESTION_517>

We strongly believe that different methodologies should be applied for determining position limits for prompt reference contracts compared to position limits on forward maturities.

In terms of forward maturities an alternative methodology to imposing position limits is to instead require market participants to disclose their position upon coming within a certain range and then to explain the reason for having that position to the relevant NCA. This promotes greater transparency for the market and regulators while not artificially restricting liquidity in contracts that are not subject to logistical constraints associated with the delivery period (expiration).

We also note that the CFTC's proposed position limits regime differentiate spot and forward maturities as follows: Spot month limit levels are set at 25% of estimated deliverable supply (separately for physical-delivery and cash-settled Reference Contracts) determined by the exchange that lists the Core Referenced Futures Contract, unless CFTC chooses to rely on its own estimate – and may not be greater than 25% of such supply but not less than 1,000 lots for agricultural commodities and not less than 5,000 lots for energy / metal commodities. Each month (i.e. single month) and all-months-combined limits, which are set at the same level, are based on largest average annual open interest in Reference Contracts in the preceding two years (10% of open interest for first 25,000 contracts and 2.5% thereafter).

<ESMA_QUESTION_517>

Q518: How should the position limits regime reflect the specific risks present in the run up to contract expiry?

<ESMA_QUESTION_518>

AFME Response

The position limits regime could introduce “telescoping” limits to avoid market disruption. This would involve stating limits in the immediate period prior to contract expiry.

<ESMA_QUESTION_518>

Q519: If a different methodology is set for the prompt reference contract, would it be appropriate to make an exception where a contract other than the prompt is the key benchmark used by the market?

<ESMA_QUESTION_519>

AFME Response

We do not think that instances where a contract month other than prompt is primarily used as the “key benchmark contract” should cause particular problems. The key risk being addressed by limits is abusive squeezes occurring as the contract approaches expiry; spot month limits will ultimately apply to all contract maturities as they approach expiry, regardless of whether some months are more traded than others; ESMA is also anticipating applying back month limits, which would govern all contract maturities outside of the spot month, which could apply to the “key benchmark contract” when spot month limits are not currently in effect.

<ESMA_QUESTION_519>

Q520: Do you agree that the baseline for the methodology of setting a position limit should be the deliverable supply? What concrete examples of issues do you foresee in obtaining or using the measure?

<ESMA_QUESTION_520>

AFME Response

As stated in our response to question 501:



Deliverable supply is the right metric for physically settled spot month contracts. For cash settled spot-month contracts, we believe that the metric should be the open interest.

We also believe that although they are expressed as percentage of open interest, limits on cash-settled spot month contracts should be as aligned as possible with limits applied to physically-settled spot month contracts.

In relation to the use of open interests for limits on physical and cash settled non-spot month contracts, as the MiFID II regime applies to a broader range of commodity derivatives than just futures and will include economically equivalent OTC contracts, it will be necessary to adjust the open interests (given is a futures related metric) to add the notional volumes of swaps relating to the relevant on-venue contract. It is also the case that certain commodities may not have a related futures contract and competent authorities will need to estimate the open interests based on notional amounts of swaps.

We also call ESMA to provide further detail on how they intend to determine the overall market size for securities contracts with a commodity underlying.

<ESMA_QUESTION_520>

Q521: If you consider that a more appropriate measure exists to form the baseline of the methodology, please explain the measure and why it is more appropriate. Consideration should be given to the reliability and availability of such a measure in order to provide certainty to market participants.

<ESMA_QUESTION_521>

AFME Response

In determining its methodology for the setting of position limits for physically delivered contracts ESMA should consider not only the defining of deliverable supply, but equally importantly the capacity for determination of deliverable supply.

Whether a trading venue or other related body is identified as the responsible calculation party, the ability for any one body to determine deliverable supply is limited by the scope of information available. For example, for medium to long term supply calculations, industry and government sponsored organisations (such as the International Energy Agency or, for oil, the OPEC reports) may have well established processes for determining structural supply and demand data, but for shorter term calculations it would most likely be the market participants that would be the key data providers for deliverable supply calculation.

In recommending a trading venue be responsible for determination of deliverable supply it is critical to provide a framework that enables the venue to access all relevant data and participants. In considering a more suitable calculation agent ESMA must consider the same availability and transparency of data. In support of the trading venue being the calculation agent, the availability of trading data across that particular venue may enable it to direct its focus to those participants most active in the relevant product most immediately and more effectively.

It should be noted by ESMA that commodity markets can exhibit very rapid changes in supply and demand balances given the global nature of those markets (where product may move in and out of region frequently given supply/demand/pricing arbitrage, and production volumes in some commodities can change very rapidly). As a result the deliverable supply, particularly where a defined set of criteria is used to determine that supply, can change dramatically and very rapidly. Shorter term supply calculations could, and would likely, exhibit a level of volatility that can disrupt the efficient functioning of the market if this short term supply volatility is manifested in rapidly changing position limits based on deliverable supply.



<ESMA_QUESTION_521>

Q522: Do you agree with this approach for the proposed methodology? If you do not agree, what alternative methodology do you propose, considering the full scope of the requirements of Article 57 MiFID II?

<ESMA_QUESTION_522>

AFME Response

We support the expression of the limits as percentage of open interests (for cash-settled contracts and non-spot month physically-settled contracts,) or deliverable supply (for physically settled spot month contracts). We note that open interest will need to be adjusted to take into account the notional value of swaps given open interest for the relevant contract will be applied to OTC equivalents.

<ESMA_QUESTION_522>

Q523: Do you have any views on the level at which the baseline (if relevant, for each different asset class) should be set, and the size of the adjustment numbers for each separate factor that ESMA must consider in the methodology defined by Article 57 MiFID II?

<ESMA_QUESTION_523>

AFME Response

We think that position limits should be sufficiently high until the regulators are able to assess the data. Downwards adjustments may be made afterwards.

Also, we foresee significant issues with adjusting the absolute baseline figures on the basis of deliverable supply, volatility and number and size of market participants. In addition we do not understand the basis for ESMA's maximum adjustment calibration of 15% of the baseline figure nor is it clear how this will be applied i.e. if the total limit 25%=-/15% how will this be applied to the spot and other months.

<ESMA_QUESTION_523>

Q524: Does the approach to asset classes have the right level of granularity to take into account market characteristics? Are the key characteristics the right ones to take into account? Are the conclusions by asset class appropriate?

<ESMA_QUESTION_524>

AFME Response

The characteristics for each class outlined by ESMA relate to the relevant exchange contract not necessarily the OTC and physical markets and these differences will need to be recognised when applying a limit e.g. a monthly OTC metals contract to a daily LME regime. However, in general we think the granularity of the taxonomy is acceptable e.g. oil and oil products class should allow for the hedging of oil products without exchange contracts via ICE's Brent Contract.

<ESMA_QUESTION_524>

Q525: What trading venues or jurisdictions should ESMA take into consideration in defining its position limits methodology? What particular aspects of these experiences should be included within ESMA's work?

<ESMA_QUESTION_525>



AFME Response

We believe that all venues should be taken into account. We think that in addition to consulting with the relevant trading venues, ESMA should continue working closely with the CFTC on harmonising their approaches.

The key consideration in defining the EU position limits methodology is harmonisation. We also strongly believe that alignment of position limits regimes will improve results and provide a powerful data set for regulators to develop accurate and more useful tools to achieve their objectives. Inconsistencies across regimes will make systems harder to build and implement across global trading businesses.

<ESMA_QUESTION_525>

Q526: Do you agree that the RTS should accommodate the flexibility to express position limits in the units appropriate to the individual market? Are there any other alternative measures or mechanisms by which position limits could be expressed?

<ESMA_QUESTION_526>

AFME Response

Expression of limits as percentage of open interest or deliverable supply is the most appropriate way. But as long as the measure of the physical underlying market is taken into consideration, flexibility may make sense in some limited cases

See our response to question 502:

We agree that amending the position limit on a real-time basis is not only unnecessarily but unfeasible and that setting it for a fixed (excluding exceptional circumstances) period is preferable. With regard to the period itself, we propose that position limits on a contract are fixed for an initial period of two years and with annual reviews thereafter with amendments to the limits only where necessary.

We also believe that spot month limits generally should not be determined at the time a contract month becomes the spot month. Determining a position limit for the spot month contract on the first day that such contract is available for trade is impractical as it would require notice of a limit to be provided when that contract has already commenced trading (open interest calculations are usually published after trading has begun each day) and when parties may already be holding positions that are in breach of that new position limit. Requiring parties to trade out of positions to comply with the new position limits may lead to artificial volatility and a disorderly market.

For instance, the LME have daily Prompt date contracts and thus have daily settlements. The LME already impose a pseudo position limit when the contract is coming up to prompt (settlement) in that it has a rule that stipulates that if the accumulated net long positions of a particular participant or member, two days before settlement, exceeds 50% of LME warranted stock, the long position holder(s) has to reduce the positions to below 50% of LME stock at a pre-determined set premium (price). It is possible to have a forward position that adds up to more than 100% of LME warranted stock. It is then up to the position holder to manage his positions over the two day period before settlement to ensure it is holding less than 50% of LME stock. LME stock figures are published each day at 09:00 UK time. We believe this is the method enshrined in the LME Lending Guidance rules that LME has been operating since 1998 is an effective tool in ensuring orderly markets and in effect imposes a pseudo position limit on LME contracts that are physically settled on the exchange. An explanation of the Lending Guidance can be found here:



http://www.lme.com/~media/Files/Notices/2011/2011_10/11_293_A286_R008_Explanation_of_Metal_Lending_Guidance.pdf

The implementation of a position limits regime will significantly affect the functioning of the commodity markets and for this reason an initial two year period is necessary to ensure that orderly trading conditions are maintained during the transition.

The measure of the deliverable supply for a period of time is challenging and ESMA and national regulators should rely on data gathered by exchanges and on existing database aiming to ensure transparency in physical markets. A one-size fits all approach such as the "three months expiry cycle" as proposed by ESMA may not fit the fundamentals of certain commodity markets.

We also highlight that data used for the purpose of defining the deliverable supply period per commodity type should span over a period of a minimum of three years and should have a granular view on a monthly basis. When calculating the deliverable supply period per commodity type, different factors must be included, among which, a basic taxonomy (i.e.: storable versus non-storable), weather, supply chain optimization level, demand and offer curve, geographical location-distance, seasonality, growth, and market concentration, as well as the trading cycles per each commodity market. As there would be differences across commodities and that some factors are outside of the control of either of the parties to the physically-settled contract, a +/- margin should be added to the averaged/estimated delivery supply period. This +/- margin could be set at no less than 15% of the overall delivery supply period.

<ESMA_QUESTION_526>

Q527: How should the methodology for setting limits take account of a daily contract structure, where this exists?

<ESMA_QUESTION_527>

AFME Response

We believe that ESMA should defer to the relevant markets here. However, care needs to be taken not to 'jam' OTC/physical trades into inappropriate daily limits.

<ESMA_QUESTION_527>

Q528: Do you agree that limits for option positions should be set on the basis of delta equivalent values? What processes should be put in place to avoid manipulation of the process?

<ESMA_QUESTION_528>

AFME Response

Yes. During the lifetime of the option, in order to minimise risk, the hedge for the option will replicate the change in delta (as opposed to the absolute value of the option). Therefore, in setting limits for options position limits should track the option delta. Regarding anti-manipulation, calculation methodology can be subject to retrospective audit from the relevant national regulator, upon request. Also, in the event options are used to hedge futures it is critical that option deltas are able to be netted with futures positions delta in order to accurately reflect commodity risk levels.

<ESMA_QUESTION_528>

Q529: Do you agree that the preferred methodology for the calculation of delta-equivalent futures positions is the use of the delta value that is published by trading venues? If you do not, please explain what methodology you prefer, and the reasons in favour of it?

<ESMA_QUESTION_529>

AFME Response

As market participants will have different internal calculation methodology for calculating delta futures equivalent values, to ensure consistency with internal risk systems they should be allowed the flexibility to use their own calculations rather than those delta value published by trading venues (subject to being able to justify the calculation).

<ESMA_QUESTION_529>

Q530: Do you agree that the description of the approach outlined above, combined with the publication of limits under Article 57(9), would fulfil the requirement to be transparent and non-discriminatory?

<ESMA_QUESTION_530>

AFME Response

Yes, we fully agree with this approach.

<ESMA_QUESTION_530>

Q531: What challenges are posed by transition and what areas of guidance should be provided on implementation? What transitional arrangements would be considered to be appropriate?

<ESMA_QUESTION_531>

AFME Response

Unfortunately, the level 1 MiFID II text does not allow a phased-in approach. However, at a minimum, the grandfathering of existing positions at the time of implementation of the new regime, along with setting of “high limits” which can be calibrated over time, is required in order to avoid market disruption and mismatched hedging.

<ESMA_QUESTION_531>

7.3. Position Reporting

Q532: Do you agree that, in the interest of efficient reporting, the data requirements for position reporting required by Article 58 should contain elements to enable competent authorities and ESMA to monitor effectively position limits? If you do not agree, what alternative approach do you propose for the collection of information in order to efficiently and with the minimum of duplication meet the requirements of Article 57?

<ESMA_QUESTION_532>

AFME Response

We agree with ESMA's approach on the purpose of the position reporting requirements.

We particularly support the expressed will to standardise the data definitions and the format of the reporting information required by MiFID with other existing legislative texts to the greatest

extent possible in order to reduce the quantity of duplicative reporting. In our view, wherever possible, we also think that ESMA should establish reporting requirements and data standards that are equivalent to, or at least compatible with, analogous requirements imposed (or proposed) by other jurisdictions. For instance, we believe that an appropriate comparison for regulators would be CFTC form 102 and 204, and the data required to be reported pursuant to Parts 15 through 20 of the CFTC's rules. In case the US and EU standards were not compatible, this would result in significant additional costs on the industry, and increase the risk of market disruption and fragmentation.

Lastly, we agree that the data fields included within position reports should include an indicator of whether a position is risk reducing for commercial purpose or not (and therefore eligible to the hedging exemption to position limits). However, we call for clarifications on the following points: a) do the requirements for members of trading venues to provide their clients' positions in on-venue contracts pertain only to that which the member holds on behalf of their client (rather than their counterparty's positions under principal transactions)?; b) if a market participant has to report positions all the way down to the "end client", how can this market participant establish whether or not the end client's position is a hedging position? c) Would the market participant be liable if the end client misinformed it (which would not be acceptable)?

<ESMA_QUESTION_532>

Q533: Do you agree with ESMA's definition of a "position" for the purpose of Article 58? Do you agree that the same definition of position should be used for the purpose of Article 57? If you do not agree with either proposition, please provide details of a viable alternative definition.

<ESMA_QUESTION_533>

AFME Response

Yes, we agree that the definition of 'position' under article 58 should be aligned with the definition under article 57 since the position reporting requirements aim to support the position limit regime. The position reporting requirements should therefore apply to contracts traded on a trading venue and economically equivalent OTC contracts. We also agree that the definition of position, alternatively called 'open interest', should embrace the net accumulation of buy and sell transactions in a particular commodity derivative, emission allowance or derivative on an emission allowance at a specific point in time.

<ESMA_QUESTION_533>

Q534: Do you agree with ESMA's approach to the reporting of spread and other strategy trades? If you do not agree, what approach can be practically implemented for the definition and reporting of these trades?

<ESMA_QUESTION_534>

AFME Response

Article 58 only requires that positions that are risk reducing transactions (i.e. netting applies to the calculation of the overall position of the market participant for the calculation of the limits but not to reporting) should be reported gross.

Any additional reporting is duplicative and unnecessary given that Investment Firms will already be reporting transactions. Looking at a gross position does not provide any regulatory useful information nor is it the way that exchanges currently receive position reports. Those positions that are not used for the purposes of 'risk reducing' should be reported net.

Any requirement to report spread and other complex trades on a disaggregated basis should be consistent with the reporting requirements imposed by other jurisdictions. For example, in certain circumstances, market participants should be permitted to report positions based on a diversified commodity index on a consolidated basis (e.g. where the index is commonly known and the weightings of individual components are publically available).

<ESMA_QUESTION_534>

Q535: Do you agree with ESMA's proposed approach to use reporting protocols used by other market and regulatory initiatives, in particular, those being considered for transaction reporting under MiFID II?

<ESMA_QUESTION_535>

AFME Response

Yes, we agree with ESMA's approach to use reporting protocols used for other transactions reporting under MiFID II but not as stated above; position reporting should be on a net position basis.

<ESMA_QUESTION_535>

Q536: Do you have any specific comments on the proposed identification of legal persons and/or natural persons? Do you consider there are any practical challenges to ESMA's proposals? If yes, please explain them and propose solutions to resolve them.

<ESMA_QUESTION_536>

AFME Response

ESMA's proposal to use LEI, BIC, National code waterfall logic will mean existing EMIR reporting methodology can be leveraged minimising new builds and facilitating implementation.

<ESMA_QUESTION_536>

Q537: What are your views on these three alternative approaches for reporting the positions of an end client where there are multiple parties involved in the transaction chain? Do you have a preferred solution from the three alternatives that are described?

<ESMA_QUESTION_537>

AFME Response

We have two major concerns regarding the reporting of the positions of an end-client:

- The protection of client confidentiality, i.e. the end-client's identity is not disclosed to the intermediaries involved in the transaction chain;
- The simplicity and cost-neutrality of the reporting system, i.e. the approach should not involve complex data fields setting that would imply onerous implementation for market participants.

With these two concerns in mind, we feel that none of the three approaches are entirely satisfactory.

As we suggest in our response to Q538, one possible solution would be to adopt the CFTC approach where an investment firm will identify its client, and the relevant competent authority will require that client (or its underlying client) to provide the relevant report. This would allow competent authorities to receive the information they require without the intermediation of the



investment firm, although there may be cases in which the client or its underlying client is unable to provide the necessary information.

However, regardless of the way in which ESMA seeks to obtain information on clients and their underlying clients, investment firms should not be prohibited from dealing with clients who are unable to provide the required information (either in relation to themselves or in relation to their underlying clients), as this is likely to result in significant barriers to market access for end clients.

<ESMA_QUESTION_537>

Q538: What alternative structures or solutions are possible to meet the obligations under Article 58 to identify the positions of end clients? What are the advantages or disadvantages of these structures?

<ESMA_QUESTION_538>

AFME Response

One possible solution would be to adopt the CFTC approach where an investment firm will identify its client, and the relevant competent authority will require that client (or its underlying client) to provide the relevant report. This would allow competent authorities to receive the information they require without the intermediation of the investment firm, although there may be cases in which the client or its underlying client is unable to provide the necessary information.

However, regardless of the way in which ESMA seeks to obtain information on clients and their underlying clients, investment firms should not be prohibited from dealing with clients who are unable to provide the required information (either in relation to themselves or in relation to their underlying clients), as this is likely to result in significant barriers to market access for end clients.

<ESMA_QUESTION_538>

Q539: Do you agree with ESMA's proposal that only volumes traded on-exchange should be used to determine the central competent authority to which reports are made? If you do not agree, what alternative structure may be used to determine the destination of position reports?

<ESMA_QUESTION_539>

AFME Response

We agree with ESMA's proposal that the determination of the central competent authority to which position reports are made should be decided solely by the volume of activity undertaken on exchanges but note that it does not take into account that the level of activity is likely to change from time to time, meaning that the relevant competent authority will also change. Firms may want some assurances that they will not be sanctioned for reporting to the wrong competent authority if there is a change.

ESMA may consider publishing a list of the relevant competent authorities, which firms could rely on for a period of time (e.g. one or two years) and which would be updated by ESMA. ESMA will also need to consider situations where a significant portion of the market is off exchange, i.e. OTC swap market.

<ESMA_QUESTION_539>

Q540: Do you agree that position reporting requirements should seek to use reporting formats from other market or regulatory initiatives? If not mentioned above, what formats and initiatives should ESMA consider?

<ESMA_QUESTION_540>

AFME Response

Yes, we agree that position reporting should seek to use reporting formats for other regulations and in particular those that are in place or being considered for EMIR trade reporting or for transaction reporting under MiFID.

We further recommend that any reporting requirements and data standards that are adopted be compatible with analogous requirements imposed by other jurisdictions. Differing data standards will require market participants to develop duplicative systems. This would be costly and inefficient. Moreover, inconsistent data standards increase the risk that regulators will receive and make policy decisions based on inconsistent market information. We therefore call, amongst other things, for consideration of the formats used for position reporting in other jurisdictions in order to facilitate both implementation and accuracy of reporting.

<ESMA_QUESTION_540>

Q541: Do you agree that ESMA should require reference data from trading venues and investment firms on commodity derivatives, emission allowances, and derivatives thereof in order to increase the efficiency of trade reporting?

<ESMA_QUESTION_541>

AFME Response

Yes, we agree that to support the position reporting of investment firms, trading venues should be required to provide reference data on on-venue and economically equivalent OTC contracts. We recognise the product identification under EMIR may not be granular enough in the specific context of position reporting of commodity derivatives for the purpose of position limits under MiFID II. We also recognise that product identification under EMIR does not incorporate the concept of linking position in on-venue contracts with 'economically equivalent OTC contracts'.

<ESMA_QUESTION_541>

Q542: What is your view on the use of existing elements of the market infrastructure for position reporting of both on-venue and economically equivalent OTC contracts? If you have any comments on how firms and trading venues may efficiently create a reporting infrastructure, please give details in your explanation.

<ESMA_QUESTION_542>

AFME Response

We believe that CCPs are best placed to report position data on OTC cleared trades, however currently some data fields such as the client identifier will be missing. Trading venues should be able to report positions either to NCAs or Trade Repositories for on-exchange contracts.

<ESMA_QUESTION_542>

Q543: For what reasons may it be appropriate to require the reporting of option positions on a delta-equivalent basis? If an additional requirement to report delta-equivalent positions is established, how should the relevant delta value be determined?

<ESMA_QUESTION_543>

AFME Response

Reporting of delta equivalent positions is established, and then consistent with question 529, the conversion to delta would need to be based on market participants' models and not be restricted by pre-defined numbers published by trading venues.

We do not think that the preferred methodology for calculation of delta-equivalent futures position should require use of the delta value published by trading venues. Instead we think participants should be able to use their own internal models / delta calculations to ensure consistency with internal records and risk systems (subject to being able to justify the calculation).

<ESMA_QUESTION_543>

Q544: Does the proposed set of data fields capture all necessary information to meet the requirements of Article 58(1)(b) MiFID II? If not, do you have any proposals for amendments, deletions or additional data fields to add the list above?

<ESMA_QUESTION_544>

AFME Response

Gap analysis should be conducted against existing reporting formats applicable to market participants. In particular, we recommend consideration of EMIR reporting formats and the CFTC's position reports, and new ownership and control reporting rules. This will ensure consistency and therefore reduction in differences in further formats.

<ESMA_QUESTION_544>

Q545: Are there any other fields that should be included in the Commitment of Traders Report published each week by trading venues other than those shown above?

<ESMA_QUESTION_545>

AFME Response

While recognising the need for the reporting fields to be specifically applicable to, and take account of, the idiosyncrasies of the European market framework and regulatory regime, both market participants and market infrastructures strongly support alignment with CFTC standards (including Commitment of Trader reports) wherever possible so as to promote consistency of reporting for all market participants with operations outside the EU (and, in particular, those active in the US).

<ESMA_QUESTION_545>

8. Market data reporting

8.1. Obligation to report transactions

Q546: Do you agree with ESMA’s proposal for what constitutes a ‘transaction’ and ‘execution of a transaction’ for the purposes of Article 26 of MiFIR? If not, please provide reasons.

<ESMA_QUESTION_546>

AFME Response

We broadly agree with ESMA’s proposals for what constitutes a “transaction” and “execution of a transaction for the purposes of Article 26 of MiFIR”.

AFME members would like to highlight to ESMA that the clarification of this definition and the additional data requirements, discussed in detail in later Q&A, mean that in many cases Firms will have to completely re-engineer their reporting infrastructure. Whilst firms are willing to resource this effort in order to comply with MiFIR – clarity of requirements early in the construction process will mean that Firms will be able to build more robust reporting solutions. Further, there are firms who under MiFID did not have a reporting obligation who will now have to build new systems and controls in order to comply with MiFIR. We should be grateful if ESMA would take the implementation challenge for firms into account when designing the transaction reporting framework, and where possible (a) where ESMA has a choice to make between various different options, consider choosing the option which would be more straightforward to implement, and (b) consider phasing in requirements over a period of time where that is possible under the level 1 text.

We wish to raise a number of points that should assist ESMA with the drafting of the subsequent RTS as required under Article 26(9) of MiFIR.

ESMA will be aware that under MiFID 2004/39/EC “Clearing Brokers/Central Counterparties were excluded from a transaction reporting obligation as they were not “executing a transaction”. Whilst we note that ESMA does not intend that activities related to settlement or clearing should be subject to the reporting obligation there may be some ambiguity. For example where an executing broker executes a bilateral OTC transaction with a counterparty and that position is subsequently novated to a Clearing House, it may not be clear as to whether this new trade would be a reportable transaction under MiFIR. In this context, the treatment of the give-up trades should be clarified. Legally there are two separate transactions however there is a grey area between what is considered a transaction for settlement and clearing purposes and a transaction under MiFIR.

Further we highlight that unless there is harmonisation between the reporting obligations under MiFIR and under EMIR it is unlikely that a Trade Repository will seek approval by the competent authority as an ARM in order to transmit transaction reports to the competent authority. The two reporting regimes will therefore continue to exist in parallel.

Further there are subsequent transactions as defined under MiFIR that would only arise between a clearing broker and its counterparty and not between the executing broker and its original counterparty that would be deemed reportable. These transactions would clearly be reportable under EMIR by the clearing broker.

ESMA should also be aware that depending on the role of the party to the transaction there will be differences in the data attributes to be populated at different stages in the lifecycle of a transaction.

Further, it would be useful for firms if ESMA would clarify what transaction time recorded for post trade events as these may be contractual in nature and therefore the time recorded more likely to be a processing time as opposed to a transaction / execution time.

Whilst it is clear that partial terminations (notional decreases) are reportable it is not clear that notional increases are reportable. It may be beneficial for ESMA to explicitly state that notional increases are reportable.

We appreciate the inclusion of the examples provided in the Discussion paper as to transactions which are deemed reportable. However we are concerned that Para 12 (v,vii) will cause ambiguity for firms.

AFME does not believe that it is appropriate to include repo and reverse repo transactions in the reporting obligations. Additionally we do not support the extension of the transaction reporting scope to buy-back contracts entered into in the context of a buy-back programme. Considering there will be a comprehensive and customized reporting requirement for SFTs under a standalone Regulation we consider it inappropriate to have additional reporting requirements for the same transactions under MiFIR, in particular as SFT transactions are not price forming.

Likewise, AFME considers that "passive" position changes - e.g. through amortisation or other contractual scheduled changes to the original reference terms of a transaction or security, should not be considered a transaction. Also, the measurement of position should explicitly exclude changes in RISK positions resulting from changes in valuations. As a strong indication, such actions would usually not get assigned a "Trade ID".

AFME does not believe that reporting of compression trades should be reportable, on the basis that they do not change relevant parties' net economic exposures and we do not consider that compression trades are susceptible to being transactions which risk being abusive. We should also be grateful for confirmation that the compression of listed derivative transactions into a position end of day are not reportable.

Under Paragraph 11 iii, exercises are deemed reportable – AFME assumes that this relates to the underlying cash security transaction that occurs as a result of an exercise event occurring resulting in the delivery of securities to the option holder and not a transaction to reflect the close out of the option position itself.

In addition some ambiguity is introduced by Paragraph 15 v, where it refers to pre established and published transactions in convertible / exchangeable bonds that are not reportable. Whilst AFME welcomes this as a principle, we would appreciate further explanation from ESMA as to the types of transactions under this heading which ESMA would not expect to be transaction reported.

In any case, it is very likely that in the absence of a golden source of reportable products firms would continue to err on the side of caution and wish to rather over report products as opposed to risk under reporting. In addition unless the technical standards clearly outline what events are and are not reportable as highlighted above – again firms are likely to err on the side of caution and potentially risk over reporting events.

Finally there is an apparent contradiction whereby ESMA clarifies that a transaction means where there is a change in position yet also extends that definition to include where a firm hits its own order on a venue. The treatment of such orders varies from venue to venue in that on some venues the orders will be cancelled, on some venues the orders will cross yet the transactions are

suppressed for the purposes of clearing and settlement whilst on others there will be two resulting transactions. Hence in some cases there is no transaction at all to report. Therefore AFME does not support ESMA's proposal of having these transactions fall within the meaning of 'execution' for transaction reporting purposes.

FOREIGN EXCHANGE

For the Market Data Reporting section of the Discussion Paper, unless the GFXD has submitted a specific response for FX, the GFXD supports the submissions made by the Association for Financial Markets in Europe (AFME) and the International Swaps and Derivatives Association, Inc (ISDA).

<ESMA_QUESTION_546>

Q547: Do you anticipate any difficulties in identifying when your investment firm has executed a transaction in accordance with the above principles?

<ESMA_QUESTION_547>

AFME Response

Where there is unambiguous guidance as outlined in our answer to Question 546 then we don't believe there will be any difficulties in identifying where an investment firm has executed a transaction. As stated a clear understanding of the roles and responsibilities of the various parties to a transaction and the subsequent lifecycle events will make identifying and reporting transactions more straightforward and reduce the risk of redundant and duplicative reports.

However, AFME is concerned about the absence of a golden source for reportable products and ESMA statement on paragraph 16 with regards to over reporting. Industry would continue to err on the side of caution and would prefer to over-report products as opposed to risk under-reporting which could lead to serious consequences such as enforcement action being taken against the firms. Firms should make best efforts not to over-report and this will be most avoided in areas where the RTSs are clear on what is in or out of scope. We do not however support the idea of having the RTS specifically precluding firms from over-reporting. We would suggest that the best way for firms to avoid over-reporting is to work closely with ESMA to ensure technical standards clearly outline what events are deemed in and out of scope for reporting purposes.

<ESMA_QUESTION_547>

Q548: Is there any other activity that should not be reportable under Article 26 of MiFIR?

<ESMA_QUESTION_548>

AFME Response

AFME wishes to point out the imperfect overlap of reporting regimes. I.e. EMIR, REMIT, obligations under Short Selling Regulation, MiFIR. MiFIR provides an opportunity to enhance the current transaction reporting regime, harmonise data attributes shared with other reporting regimes and allow regulators to take a holistic overview of reporting requirements so as not to duplicate obligations.

We reiterate that all securities financing transaction should be out of scope for transaction reporting purposes, and thus repo and buybacks contracts should remain out of scope for transaction reporting purposes.



Further, AFME considers that in line with 15 (vi) waiving condition for transactions within the same legal entity intra-group transactions undertaken for the purposes of transferring risk within corporate groups should not be subject to a transaction reporting requirement.

<ESMA_QUESTION_548>

Q549: Do you foresee any difficulties with the suggested approach? Please elaborate.

<ESMA_QUESTION_549>

AFME Response

Under current reporting arrangements investment firms already make the necessary transaction reports as described on the occasions when they transmit an order to another investment firm and don't pass on all the necessary details for that firm to make a complete transaction report. This scenario occurs largely in the Exchange Traded Derivative arena where an executing broker passes a client order for execution to a second executing broker. The details of the underlying client are not passed to the second broker hence the first executing broker makes a transaction report in order to ensure that the regulators have a complete view of the parties to the transactions.

We acknowledge that ESMA has made it clear that only orders that result in transactions are reportable under MiFIR.

However, there are several concerns we wish to raise with this as to the practical application of this requirement to bilaterally agree arrangements between firms to allow the firm transmitting an order to not make its own transaction report.

The order received doesn't contain all the details of the transaction with regards to the economics of the resulting transaction. E.g. the final transaction price / quantity – although it can contain details as to the order type.

A large number of bilateral agreements will have to be in place between investment firms and their clients, that are not currently in place, in order to allow both sides to be clear that a transmission of an order has taken place for the purposes of Article 26 (4).

In addition it is clear from the obligations that data not normally present on an order would have to be provided although we would assume that the information required on the transaction report is determined as it is today from the order, the allocation and the firm's own reference data.

The current arrangements under MiFID have worked satisfactorily for both buy and sell side firms. At present, firms currently report at the block or allocation level depending on the type of trade, however, under MiFIR, the beneficiary information will be required on the report. Firms would like to highlight to ESMA that the beneficiary information may not always be available in the required time scales of T+1, and will only be available if provided by the investment manager.

<ESMA_QUESTION_549>

Q550: We invite your comments on the proposed fields and population of the fields. Please provide specific references to the fields which you are discussing in your response.

<ESMA_QUESTION_550>

AFME Response

AFME would like in addition to make more general comments as to the use of the fields:

- There are insufficient fields to adequately identify complex derivatives. This has been the case for MiFID 1 and firms request more clarity on how these fields should be populated to represent complex products.
- As under EMIR – with the introduction of more transaction types and products firms request that the level of detail required by the Technical standards is sufficient to allow them to accurately transaction report the necessary details of the transactions to NCAs.
- Further consideration should be made into the issues surrounding the accurate representation of new products types including Commodity / FX and Interest Rate products. Where appropriate when standards are agreed under EMIR then firms recommend that these should be used.
- There is no field to indicate where the transaction is not a buy or sell e.g .a notional increase. Firms anticipate that a further field akin to that used for EMIR – Action Type is also required.
- Not all transactions will require all the fields to be populated hence the definitions of mandatory and optional should be considered carefully by ESMA in the RTS.
- There is no detailed field to indicate short selling when appropriate.
- The reporting regime today has evolved such that many of the ambiguities have been ironed out either as a result of guidance or as a result of best market practice.
- AFME is concerned that the introduction of many additional fields / events and products will lead to an increase in the ambiguity and hence risk to the current stable reporting regime.
- AFME would be willing to participate in open dialogue with ESMA over the course of the MiFIR implementation but are concerned that the QA process and the high level requirements will be problematic for firms who will in many cases, have a reporting obligation for the first time and in many cases be re-engineering their solutions to take into account the additional reporting required.
- For several aspects of the reporting a golden source of instrument reference data to identify reportable instruments would be essential.
- For many derivative transactions both OTC and ETD there is no "consideration" as calculated in terms of a monetary value. i.e. The consideration is a "theoretical" value rather than an "actual" value. The values expected in this field would be further complicated in the case of complex / exotic derivatives. Firms request further guidance as to how this field should be populated. In some cases a change in position is effected for zero consideration
- It would be beneficial for ESMA to clarify its position on the use of Operating MICs and Segment MICs. The segment MIC is often not received on the venue's execution file and the segment MIC cannot be determined from usual reference data channels.
- How does ESMA envisage we report products for which a request for admission to trading has been made but don't yet have an ISIN?
- In general terms for product classification purposes Firms encourage ESMA to utilise standards agreed under EMIR yet firms are aware that standards have not yet been agreed nor endorsed by ESMA under EMIR.
- The Report Matching number is a new concept and requires careful consideration as to its usefulness and implementation. As ESMA clearly intends for a one sided reporting obligation and that it is impossible to match multiple market executions to often multiple client transactions using a single reference number then Firms suggest that it only makes practical and useful sense for this field to be populated on market side executions and that can only be populated by Firms where the venue makes the value available on the execution file and that the venue makes



this available to both sides to the transaction. Furthermore there may be issues with the population of this field where a transaction is made on a reportable security yet on a venue outside of the EEA.

- Additionally, we foresee problematic concerns with data protection and privacy, in particular where clients are situated outside the European Union and outside local legal obligations, where using the information for commercial purposes. Members have already observed such situations already under EMIR reporting.

<ESMA_QUESTION_550>

Q551: Do you have any comments on the designation to identify the client and the client information and details that are to be included in transaction reports?

<ESMA_QUESTION_551>

AFME Response

Since MiFID go live in 2007 our members have worked to increase the quality of the static data used in the reporting of transactions. For full service firms facing largely institutional “legal persons” use of the BIC code has become the de-facto standard for MiFID transaction reporting.

As a result of EMIR coming into force there has been a strong take up of the LEI and firms have sought to populate their reference data systems with counterparty LEIs, investing in ensuring that counterparties have LEI for use in EMIR Trade Repository reporting.

AFME is therefore fully supportive of the move to use LEI for the identification of Legal Persons. The number of LEI is approaching 300,000 and there is sufficient choice of LOUs where a Legal Person can register and maintain its LEI.

However we wish to raise the following points:

The proposals in the Discussion paper put the burden on Investment firms to determine whether a Legal Person is eligible for an LEI or not and hence should be reported with or without an LEI. We do not believe that firms are in the position to make this determination. The Local Operating units, in conjunction with the Legal Person, are better placed to determine this status at the time of registration. In addition the Level 1 Regulation does not oblige Investment firms to ensure their clients apply for LEIs.

We welcome the clarification by ESMA in paragraph 49 that an LEI eligible client must apply for one before it can commence or continue trading. However it is not clear as to whether this is a legal obligation under the Level 1 Regulation for clients of EEA regulated firms to obtain an LEI where they are eligible to get one. This therefore introduces ambiguity into a process where different firms and different NCA’s could choose to interpret regulation differently in making LEI a feature of tradability determination. We strongly suggest that the guidance be clarified to state that the legal person is required to obtain an LEI. If such guidance were provided, firms could more easily incorporate a process into their onboarding standards for asking clients to obtain an LEI .

AFME is comfortable with encouraging their clients to apply for LEIs and usage under MiFIR will be high amongst Investment firms who also have an EMIR reporting obligation. However, the regulation does not state that Investment Firms are obliged to ensure that clients obtain and maintain their LEI. Obtaining and maintaining the LEI should be the liability of the Legal Person. AFME’s view is that there should be no requirement on investment firms to restrict trading in any way due to their client's lack of an LEI. A clear statement from ESMA that this is the case would be welcomed.



We recognise that there will be rare instances where clients are unable to obtain either an LEI or a BIC code. In these cases, it is suggested that a unique identifier internal to the firm is used to identify the client within the investment firm.

Furthermore, it is not clear what is meant in Paragraph 50 for identifying non EU legal persons that have neither a BIC nor LEI. We don't believe that there are at present national codes within the EEA that are sufficiently standardised to identify non EU legal persons and that are maintained on a national basis. As a result, we strongly recommend that guidance request all legal persons requiring identification under MifID to use an LEI code. By requiring the use of the LEI for all counterparties identified in the regulatory reporting, legal entities transacting in the EU who have not already done so will need to obtain an LEI. Although we acknowledge that the rule cannot require a counterparty, issuer or other reported entity beyond its oversight to obtain an LEI, the broad requirement to use an available LEI to identify all entities in regulatory reporting will reinforce the adoption of LEI as the standard for entity identification. Requirements like this will greatly expand the collective benefit from widespread adoption of the LEI for all legal entities.

Additionally, firms would appreciate further clarity as to the identification of the counterparty to the transaction. Under EMIR, the fund – where it is eligible for an LEI should be identified. Our understanding of the MiFID text is that the Investment Manager should be identified.

Further, AFME wishes to highlight the operational complexity for investment firms to provide cumbersome client information fields as the considered by ESMA in paragraph 58 (address and date of birth) which do not provide further valuable information for transaction reporting and transparency purposes. We consider such fields should be removed as requirements. Requiring the inclusion of an individual's name, address and date of birth on a systematic basis increases the risk of identity theft in cases where such information is not transferred or retained in a secure manner. AFME considers that the data protection risk of including full personal details in transaction reports outweighs the potential benefit of including such information.

With the introduction of additional fields around client identification and decision makers such as "Counterparty Identification", "Decision Maker for Counterparty", "Client Identification", "Decision Maker for Client Identification", firms are concerned that there will be ambiguity as to what data needs to be populated in different circumstances, the quality of the data and how to source this information. Again we welcome the opportunity to work further with ESMA as to the detail that will be required.

<ESMA_QUESTION_551>

Q552: What are your views on the general approach to determining the relevant trader to be identified?

<ESMA_QUESTION_552>

AFME Response

AFME members consider that in many cases it is impossible to isolate the responsibility of a single trade in a committee or a person. ESMA should contemplate certain circumstances where multiple persons (and not necessarily committees) are involved in a trade, when a remote individual such as a sale person is involved in a trade, or the common market practice of compression trades.

Furthermore, ESMA should account that trades commonly follow internal committee guidelines which are afterwards executed by a person or a group of people.

AFME again wishes to raise comments as to the use of Agency and Principal definitions in this context as firms overwhelmingly transaction report to reflect the contractual arrangements with their clients and not to reflect the capacity in which they placed the order on a venue.

Members have, since MiFID go live, used the capacity field to reflect the fact that although orders may be routed to venues using an indication that the firm is acting on behalf of a client (Agency), riskless principal or principal the majority of brokers have adopted the principal model of settlement irrespective of order capacity. Hence transaction reports show the capacity as being the same capacity as the trade is confirmed to the client. This reflects either the contractual arrangements between clients and firms or in some cases to describe whether an execution price has been passed directly to a client without change.

In almost all cases settlement remains on a principal to principal basis yet a firm may choose to apply the agency capacity to reflect how a price has been passed to a client rather than use the stricter legal relationship between a client and a firm.

In this context therefore depending on the definition of capacity used, firms will either populate the trader ID infrequently as they'd consider this question in their order placing capacity or they populate this field frequently as they consider their capacity in terms of their contractual relationship with their clients.

Therefore firms would appreciate a better understanding of the capacity designation and how ESMA intends firms to use it before the use of Trader ID can be fully considered. We would welcome further discussion with ESMA on this point.

Further there are concerns with using a Traders National Identity number on transaction reports, firms suggest that there are other more suitable items of identification that could be used and are already used within firms to identify individuals for example the National Competent Authorities registration number. Firms already have in place Personal Account Dealing controls to monitor the activities of all staff where trading for their own account. In respect of the information to be provided in respect of Trader IDs, AFME requests that only a numeric ID to represent such individual (per ESMA's description in paragraph 38 of the DP) should be required as part of transaction reports. Requiring the inclusion of the individual's name, address and date of birth on a systematic basis increases the risk of identity theft in cases where such information is not transferred or retained in a secure manner. AFME suggests therefore that national authorities continue to request such information from investment firms on an ad-hoc basis.

<ESMA_QUESTION_552>

Q553: In particular, do you agree with ESMA's proposed approach to assigning a trader ID designation for committee decisions? If not, what do you think is the best way for NCAs to obtain accurate information about committee decisions?

<ESMA_QUESTION_553>

AFME Response

No. AFME is unsure as to why it would be necessary to involve a separate committee in this instance.

This requirement will create ambiguity as to how firms interpret the role of committees who likely ratify investment decisions and make risk assessments as opposed to making the original investment decision. What is also clear is that not all investment decisions will be made by Standing Committees and that some decisions are likely made by informal groups yet all will ultimately be executed by a single trader. It is hard to envisage how to accurately and reliably capture investment decisions made by Standing Committees / Ad Hoc committees without such data being keyed at the time an order is placed by the trader who will ultimately manage the risk.



We therefore suggest that the use of this ability to reflect investment decisions be a choice made by individual firms as appropriate to their business.<ESMA_QUESTION_553>

Q554: Do you have any views on how to identify the relevant trader in the cases of Direct Market Access and Sponsored Access?

<ESMA_QUESTION_554>

AFME Response

The person and the “user” of a firm’s Direct Market Access service is the person who makes the investment decision, whilst the trader is whichever algo or trader executes the order within the firm providing the DMA.

AFME notes the following comments in relation to DMA:

The onus is on the DMA user to provide this information.

The DMA provider is not responsible.

Smart router is the exception (then algo flag is applicable).

<ESMA_QUESTION_554>

Q555: Do you believe that the approach outlined above is appropriate for identifying the ‘computer algorithm within the investment firm responsible for the investment decision and the execution of the transaction’? If not, what difficulties do you see with the approach and what do you believe should be an alternative approach?

<ESMA_QUESTION_555>

AFME Response

No. AFME is supportive of the approach although suggest that the same scenarios are used to describe the use of Trader ID We point out again that improved clarity as to the use of the capacity designation will impact the use of this field. Where a chain of Algos is involved in the execution of a transaction the last one in the chain should be reported.

AFME wishes to make very clear that different sequences be assigned different algo codes. There are several algo codes which should be considered here for example the first algo code is the one which would have 'made the decision' to trade whereas the last algo code is the one which carried out the execution for the algo. Therefore it is important to distinguish between such difference in algos and what they do. In addition firms would appreciate clarity as to exactly when ESMA deems when a new Algo has been created. Firms would suggest that is when the core logic of an Algo has been changed and not when an Algo is passed a different input parameter.

<ESMA_QUESTION_555>

Q556: Do you foresee any problem with identifying the specific waiver(s) under which the trade took place in a transaction report? If so, please provide details.

<ESMA_QUESTION_556>

AFME Response

It is not yet clear at industry level as to how the various waivers proposed under MiFID/MiFIR will be calculated and determined. We are therefore unable to comment as to the challenges firms may yet encounter with the population of this field. ESMA should provide for a standardised method for the reporting of waivers.

<ESMA_QUESTION_556>

Q557: Do you agree with ESMA’s proposed approach to adopt a simple short sale flagging approach for transaction reports? If not, what other approaches do you believe ESMA should consider and why?

<ESMA_QUESTION_557>

AFME Response

No. Identifying short selling at a legal entity level at an Investment Firm using transaction reports is not possible.

- Although overall positions are of course monitored for risk management and settlement purposes these monitoring systems are entirely separate from trade capture systems. Individual traders will be able to determine that they themselves are going short on their individual trading accounts but they will not on a transaction per transaction basis be able to determine / nor flag if their transaction will cause the Firm to go short. Chinese walls and data segregation means that this data is not – deliberately – available to individual traders.

- AFME members note they have implemented systems and controls in order to comply with their obligations under the existing short selling regulation which includes disclosures monitoring and checks to the firms list of securities for which they have the market making exemption.

- Hence we do not think transaction reports are a suitable medium for monitoring short selling activity at a legal entity level.

- AFME suggests therefore that this field might be used to consider short positions at a firm trading account level but should bear in mind that many transactions flagged in this way may not ultimately at end of day result in a short position.

- Further, AFME considers that where a firm is under the market making exemption, the firm should not have to flag a short selling at all as most are out of the scope of the obligation.

- AFME suggests that an alternative approach to reporting would be to include an additional field designating on which aggregation (desk, firm, group, etc) the short selling status has been determined.

AFME would agree that a simple short sale flagging approach is best to identify that a transaction represents a short sale of shares or sovereign debt. For that reason the designation in paragraph 94 would be best and our members would not be in favour of any complication which might be introduced by use of a something such as the partial flag suggested in paragraph 95. The proposed short sale flag designation should be used to designate as a short sale only the transaction which is being reported.

As discussed in questions 558-561, a trader may not always know whether a transaction is a short sale. Therefore, the short selling flag should be set up so that firms are only required indicate whether a transaction is a short sale where this information is available. For example, this could be achieved by an optional tick box, which would be ticked where the firm is aware that the transaction is a short sale.

<ESMA_QUESTION_557>

Q558: Which option do you believe is most appropriate for flagging short sales? Alternatively, what other approaches do you think ESMA should consider and why?

<ESMA_QUESTION_558>

AFME Response

Option 1 is the most appropriate; whereby the firm will rely upon the voluntary disclosure of a client as to whether a transaction is a short sale (upon request by the firm to the client to disclose such information).

The infrastructural and commercial problems which would be introduced in option 2 where investment firms would have to calculate the holdings of their clients to determine if the transaction which is being reported represents a short sale would outweigh any suggested benefits. Indeed, investment firms may not even be able to calculate a full holding if the client has their stock held at different custodians. As acknowledged in paragraph 101 of ESMA's paper, an investment firm will rarely (if ever) know or have visibility over whether any given client holds relevant shares/sovereign debt in a custody account with a third party, and so an investment firm will never be in a position to accurately flag whether any given sale by such a client is a short sale or not.

<ESMA_QUESTION_558>

Q559: What are your views regarding the two options above?

<ESMA_QUESTION_559>

AFME Response

Option 1 is the most appropriate. As ESMA indicates in paragraph 105, it would be consistent with the principle that investment firms should report transactions executed on a principal basis from its own perspective, and will prevent confusing double-reporting in case an investment firm's counterparty is another investment firm.

Further, the designation of the short sale should only be from the point of view of the trader or decision maker executing the transaction which is being reported, and not at a legal entity level, given that to monitor holdings at any higher level would be complex and costly to implement. The trader executing the transaction cannot be expected to have a view outside their own desk etc.

AFME's suggested approach could be achievable using the existing infrastructure implementing the Short Selling Regulation (SSR). The infrastructure required to be compliant with the SSR (to both identify short sales and designate them as taking place under a market making waiver) should allow a firm to identify when a transaction it is executing in a principal capacity is a short sale. The book segregation at an investment firm should also allow it to know when it needs to be concerned with the designation and when it can expect to receive the designation from its client.

<ESMA_QUESTION_559>

Q560: Do you agree with ESMA's proposed approach in relation to reporting aggregated transactions? If not, what other alternative approaches do you think ESMA should consider and why?

<ESMA_QUESTION_560>

AFME Response

AFME agrees with ESMA's proposed approach in relation to reporting aggregated transactions. The designation of the short sale flag should for the market side leg be as if the investment firm is trading as principal while the designation of the transaction as a short sale for the client side legs should be as indicated by the client at execution.

<ESMA_QUESTION_560>



Q561: Are there any other particular issues or trading scenarios that ESMA should consider in light of the short selling flag?

<ESMA_QUESTION_561>

AFME Response

It is AFME's opinion that the flagging of short sales applies to transactions in shares and sovereign debt only.

We do not support ESMA's proposal on the short selling flag with regards to market making activities and primary market operations. We do not think that the short selling flag should apply to these activities nor should they be required to flag whether a short sale took place under the market maker exemption or the primary market operation exemption under the SSR. We believe this information is already available to regulators and would not add any value.

Under Level 1, it is AFME's understanding, that those short sales which benefit from the market making exemption do not need to be flagged at all. This is because Article 17 of the SSR disappplies Articles 12 and 13 of the SSR for transactions performed due to market making activities. Therefore, AFME does not consider it reasonable to require market makers to flag whether they are short selling and would suggest for market making activities and primary market operations to be completely exempted from the short selling flag under transaction reporting. This is also in line with the overarching ESMA's concept of keeping the short selling flag process simple.

<ESMA_QUESTION_561>

Q562: Do you agree with ESMA's proposed approach for reporting financial instruments over baskets? If not, what other approaches do you believe ESMA should consider and why?

<ESMA_QUESTION_562>

AFME Response

Our members have considered the problem of reporting baskets and indices many times since MiFID implementation in 2007 and dialogue has failed to produce a solution that is practical to implement and that would provide meaningful information for regulators.

We suggest therefore that firms report all baskets and indices irrespective of analysis of their composition to determine if the basket contains a reportable security or not. Where the underlying index or basket is "standardised" then firms should use an ISIN code where available to identify the underlying index or basket. An additional field on the reporting message should be made available for firms to identify the underlying as an Index or Basket. A numbering agency might be requested to create ISINs for all the standard indices across the EU and also non-EU indices issued on EU exchanges, for example KOSPI (Korean) futures issued on Eurex.

Further in order to identify the most relevant underliers to regulators ESMA might consider this approach for non standardised baskets / indices. Some regulators have taken the 20% rule – whereby if a single constituent is a financial instrument reportable under MiFIR and makes up > 20% of the basket then the reporting firm should identify it and it alone. The product description could where feasible be used to indicate to regulators the "broad" composition of the Basket/Index. Changes in the composition of the basket are clearly not reportable transactions. Again firms suggest that a single source of reportable products would clarify matters here.

<ESMA_QUESTION_562>

Q563: Which option is preferable for reporting financial instruments over indices? Would you have any difficulty in applying any of the three approaches, such as determining the weighting of the index or determining whether the index is the underlying in another financial instrument? Alternatively, are there any other approaches which you believe ESMA should consider?

<ESMA_QUESTION_563>

AFME Response

Please see our answer to Question 562.

<ESMA_QUESTION_563>

Q564: Do you think the current MiFID approach to branch reporting should be maintained?

<ESMA_QUESTION_564>

AFME Response

Yes. We are supportive of the current regime.

<ESMA_QUESTION_564>

Q565: Do you anticipate any difficulties in implementing the branch reporting requirement proposed above?

<ESMA_QUESTION_565>

AFME Response

No. We are supportive of ESMA's proposals.

However firms anticipate that ESMA will define criteria as to what activities should be flagged.

Also, this rule only works for branches of EEA firms and ESMA's proposal is silent on the obligation of branches of non-EEA firms, where the head office of the branch is located in a non-EEA country. We would appreciate further clarity as to who these branches will be required to report to and would suggest that a primary home EEA NCA be designated based on materiality.

<ESMA_QUESTION_565>

Q566: Is the proposed list of criteria sufficient, or should ESMA consider other/extra criteria?

<ESMA_QUESTION_566>

AFME Response

Yes. The list is sufficient.

<ESMA_QUESTION_566>

Q567: Which format, not limited to the ones above, do you think is most suitable for the purposes of transaction reporting under Article 26 of MiFIR? Please provide a detailed explanation including cost-benefit considerations.

<ESMA_QUESTION_567>

AFME Response

Since MiFID go live in 2007 the services provided by Approved Reporting Mechanisms have altered to take into account the demands made of firms by National Competent Authorities. The market has worked well and technological advances alongside services provided by the ARMs has meant that firms are able to send reports in either proprietary or non proprietary formats.

We would be supportive of non proprietary formats including XML.

<ESMA_QUESTION_567>

8.2. Obligation to supply financial instrument reference data

Q568: Do you anticipate any difficulties in providing, at least daily, a delta file which only includes updates?

<ESMA_QUESTION_568>

AFME Response

Yes. AFME believes that there will be difficulties

(i) *There needs to be a golden source of securities in scope together with reference data available to the market*

Before identifying the data and means by which the data is collected/submitted, it is essential to set out what the data is for and how it will be used and who will undertake this role. By setting out the clear objectives and roles, it becomes simpler to determine the protocols for the in-flow/outflow of information.

We strongly recommend that there needs to be a central list identifying instruments in scope of the transaction reporting requirements and transparency requirements that the industry can access (“the golden list”). Without a centralised approach, it will be operationally unfeasible for industry to comply with the requirements. Especially in the bond markets, where instruments dynamically fall in (e.g. instruments are issued or become listed) and out of scope (e.g. instruments mature or may become delisted). Further, there are hundreds and thousands of bonds globally that could be in scope of MIFID. Firms cannot look up different lists across the whole of Europe and be expected to comply with the publication requirements in real time – this is not only operationally challenging but also promotes a high degree of inconsistency and error. We note that in the US, under the TRACE regime, which is a working system, FINRA maintains and updates a single list of securities in scope. We are concerned that if a centralised infrastructure is not introduced, bottlenecks will be created and issuance and trading will be impacted. Further, lack of infrastructure will result in poor compliance and poor quality data.

The golden list needs be available to the public at all times. It also needs to be machine readable and available to download in an industry wide accepted format in a timely manner - so that investment firms/APAs/venues can download the information and meet their transaction reporting/transparency requirements (it is also essential that small firms can access the information). Simple publication of lists on ESMA’s website is not sufficient (given the volume of information). However, web browser-based access is important for small firms. There are many industry standards for formats of files that ESMA could adopt (i.e. how to download the information) – for example, XML, JSN URL. We don’t recommend CSV to be used (due to commas).



With regards to accessing the reference data, ESMA needs to provide query tools to the database so that firms can search the data (by field and by date). TRACE provides this capability¹⁹ (see page 73 of the TRACE “Reporting and Quotation Service: OTC Corporate Bond and Agency Debt User Guide”, Version 4.2m 25 April 2014).

Fixed Income / TRACE / Corporate & Agency Debt / Daily List

Daily List Type: Security Search By: Symbol Search Criteria:

From Date: 1/1/2013 To Date: 2/1/2013 Category: SA-Security Addition Sub-Product: Filter

| DL Date | DL Time | DL Reason Description | Sub-Product | Trade Report Effective Date | Symbol | CUSIP | Bloomberg Symbol | Issuer Name |
|------------|----------|----------------------------|-------------|-----------------------------|-------------|-----------|------------------|-----------------------------|
| 01/02/2013 | 15:57:05 | BK-New Addition | AGCY | 01/03/2013 | TEST3947091 | TEST12340 | | TEST 1234 0 |
| 01/04/2013 | 15:26:32 | | ELN | 01/09/2013 | | 284904109 | | ELECTROFUEL INC |
| 01/09/2013 | 08:18:33 | | ELN | 01/08/2013 | TVCR3949113 | 894174200 | | TRAVELCENTERS AMER LLC |
| 01/16/2013 | 11:52:21 | DEX-Delisted from Exchange | CORP | 01/16/2013 | JPM3950868 | 46625H647 | BBG00008N140 | JPMORGAN CHASE & CO |
| 01/16/2013 | 11:52:35 | DAR-Delisted from ARCA | AGCY | 01/16/2013 | OPIZ3950869 | 690353WC7 | BBG003M5P8Z4 | OVERSEAS PRIVATE INVESTM |
| 01/16/2013 | 11:53:05 | DEX-Delisted from Exchange | CORP | 12/16/2010 | 8AC3950870 | 06052R476 | | Bank of America Corporation |
| 01/16/2013 | 11:56:51 | DEX-Delisted from Exchange | CORP | 01/16/2013 | UBS3950871 | 90205K205 | BBG0015WRQZ6 | UBS AG |
| 01/16/2013 | 12:25:52 | DEX-Delisted from Exchange | CORP | 01/16/2013 | 8CS3950872 | 06740C238 | BBG001910D34 | BARCLAYS BK PLC |

Figure 22
Daily List Security

For using the data, firms need to be able to download the changes to the golden source (i.e. a delta file – e.g. which instruments have been newly added to the list of instruments in scope, or which instruments have been removed) as well as having access to the full file – otherwise, firms/venues/APAs would need to refresh their entire systems on a daily basis for hundreds of thousands of ISINs (rather than amending according to the delta file).

Therefore, firms should be able to download delta files and full files. TRACE solves for this by having a search filter by category (additions, deletions and changes) – once you apply the search through the query tool, the list can be downloaded. Alternatively, the delta list could be provided by ESMA separately and be made available on a daily basis. The delta could be a number of files (with a maximum number of lines of 10,000) that firms can keep downloading until the last file – this is what we think would be the most simple approach for a separate delta file that small firms could implement.

TRACE search filters are:

- Daily list type
- Date range
- Search criteria
- Category (additions, deletions, changes)
- Subproduct

Key fields that the full and delta lists will need to have:

- Date
- ISIN

¹⁹ <http://www.finra.org/web/groups/industry/@ip/@comp/@mt/documents/appsupportdocs/p493610.pdf>

| |
|---|
| Instrument type (bond/SFP/derivative etc..) |
| Reference Data |
| Effective date |
| Application for admission/admission for trading/traded on venue |
| Delisting date |
| <i>Key additional fields the delta file will need (it will not contain instruments for which there has not been a change)</i> |
| Change date |
| Change (field of reference data/effective/delisting) |
| The full list will also require a field for instruments that are no longer in scope – we propose a field where the termination date is populated if relevant for that instrument. |

(ii) *One list for reference data with regards to instruments in scope for transaction reporting and trade publication*

We believe that it is critical for there to be as few lists as possible for industry and regulators to process (to ensure that the infrastructure is not unnecessarily bulky). We note that transaction reporting (under MiFIR Article 26 applies to instruments admitted to trading, where an application has been made for admission and instruments that are traded on a trading venue). For trade publication, the requirements apply for instruments traded on the trading venue. As such, we believe that it is important for the venue in its notification to the NCA which of the three criteria the instrument has met – this should then be published to the industry so that they can differentiate whether a trade is in scope for both transaction reporting and trade publication.

As we provided in our response to **DP Question 132**, we recommend that the grey market should not be included within the post trade transparency regime (it is an instrument for which there is an application for admission). Grey market activity takes place prior to admission to trading on trading venues. If grey market is included, the instruments will most often not have an ISIN code, meaning it is highly likely that the instrument may get published under a number of different reference identifiers. We believe that this would undermine the value of the information.

It is important to note that a significant number of venues do not have a list of instruments available to trade (any instrument outstanding can be traded on the venue). For example, IDBs do not have a formal admission procedure; any instrument can potentially trade at any point. It is operationally unfeasible for venues to provide a list of all securities outstanding in the global market on a daily basis (i.e. track all bonds outstanding/issued/matured globally). Further, not all bonds are active on venues. For example, as of July 2014, there are approximately 1.7 million bonds listed on Bloomberg – of those, only approximately 300,000 are active (i.e. have not matured) and approximately 20,000 have a composite price (at least three dealers are providing

an indicative price). Therefore, it is important that the list relates to instruments that are in fact traded on the venue rather than potentially available to trade or just available or listed.

- (iii) **First venues should only be required to provide the full set of reference data for an instrument and second venues should provide notifications of application/admission/traded on venue**

Having many venues across Europe providing the same information on the same instruments is excessively duplicative, is unnecessarily cumbersome and could result in inconsistent data. For example, venues could populate the reference data fields differently, which would require a complex reconciliation process.

If an instrument is already on the golden list then a venue that newly admits the instrument should not be required to also send the same data on that instrument. Therefore, we propose the following protocol:

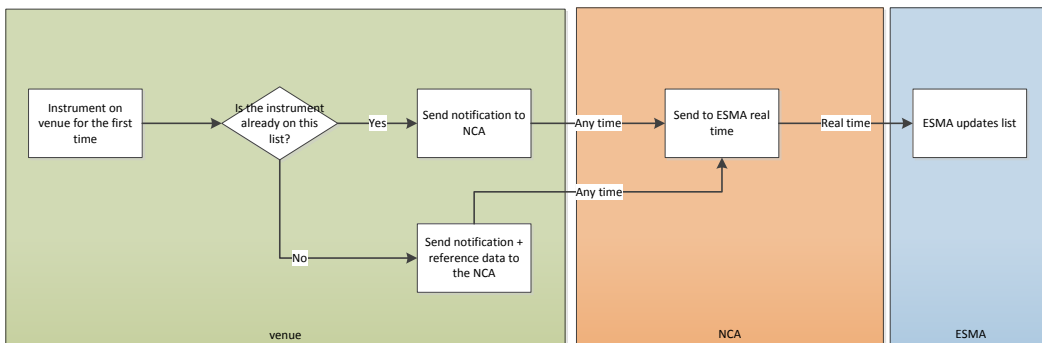

The protocol works as follows: the venue checks whether an instrument is on the list. If it is, it will not send the reference data to the NCA. If it is not, then it will send the reference data to the NCA. If the instrument is admitted for the first time on two different venues on the same day, then duplication cannot be avoided. In these circumstances ESMA needs a reconciliation process.

Given that the first venue will be responsible for the reference data, it will mean that ESMA will need to implement a correction process. For example, the first venue may populate the information incorrectly. We suggest that anyone can submit a correction to NCAs but they need to provide evidence. We note that venues should be able to provide updates as a “change”. In the event of a correction, we stress that it would be excessively onerous if investment firms and venues were required to make historical amendments to their transparency/transaction reports. Amendments should only apply to future reports.

In the event that a venue does not provide the reference data (because it is a second venue), it still needs to provide a notification in the daily file that the instrument is: (i) admitted to trading on its venue and/or (ii) whether there has been an update and/or (iii) there is a delisting. For example, the instrument could be delisted on the first venue but would still be in scope because it continues to trade on other venues. Therefore, the file would need to contain the following fields (for both the second and first venue):

| Date | ISIN | Create/update/delete | Admitted to trading | Traded on venue | Application to trade | Reference data fields | Delisting |
|------|------|----------------------|---------------------|-----------------|----------------------|-----------------------|-----------|
|------|------|----------------------|---------------------|-----------------|----------------------|-----------------------|-----------|

| | | | | | | | |
|--|--|----|------|------|------|------|------|
| | | “” | DATE | DATE | DATE | DATE | DATE |
| | | | | | | | |

For create – the admitted to trading/traded on venue/application to trade field is populated. For the first venue the reference data fields are also populated

For update – there relevant field is update (e.g. whether it has gone from application to admission or the reference field is updated)

For delete – the delisting field is updated

The reference data fields are only populated by a second venue in the event of an update)

We note that it would helpful for ESMA to provide market participants with a list of all venues for each instrument – this would be valuable information for the market.

(iv) **Venues should be required to provide delta files on a daily basis**

We agree that venues should be required to provide delta files on a daily basis. However, venues should be able to send information to the NCAs (i.e. a new instrument or an update as a first or second venue) at any time during the day.

We strongly recommend against a full list being provided on daily basis. A requirement to provide full lists on a daily basis would be operationally unfeasible - relating to central consolidation and implementation at investment firm/venue/APA level (i.e. the whole system to refresh the data for hundreds and thousands of bonds).

We do not believe two daily lists being produced by ESMA is necessary given the additional complexity. We do not believe highly frequent updates to the central list of instruments in scope should be introduced, not only because of operational issues, but because there could be economic impacts. We believe a single daily list will ensure greater consistency, a more operationally sound system and better informational quality.

We propose the following timings,

- Venues can provide NCAs with the notifications at any point during the day (24 hours a day).
- NCAs provide the notifications to ESMA in real time.
- There is a closing time for the notification being included in the daily list for the next day (8pm UTC) – i.e. any trade received from 8pm UTC (previous day) to 8pm UTC (current day) is included in the daily list for the next day.
- ESMA makes the new consolidated daily list available by 10pm UTC.
- Investment firms/venues/APAs should adopt the new consolidated daily list by 12am UTC.

We propose ESMA to consider using the FIX trading protocol to receive notifications.

<ESMA_QUESTION_568>

Q569: Do you anticipate any difficulties in providing, at least daily, a full file containing all the financial instruments?



<ESMA_QUESTION_569>

AFME Response

AFME does not agree with a full file being provided on a daily basis.

A requirement to provide full lists on a daily basis would be operationally unfeasible - relating to central consolidation and implementation at investment firm/venue/APA level (i.e. the whole system to refresh the data for hundreds and thousands of bonds). The data handling required by the industry and regulators would be highly intensive. It is also unnecessary; it is much simpler to use a delta approach and more effective. For example, if a bond has a term of 15 years and nothing changes in those 15 days, the same data regarding that bond should not be submitted, consolidated and implemented on a daily basis for the 5475 days it is outstanding – the scale of the problem with full lists is then further inflated when it is multiplied by hundreds of thousands of bonds.

We propose for a full list to be provided annually – this would mean a full refresh once a year.

<ESMA_QUESTION_569>

Q570: Do you anticipate any difficulties in providing a combination of delta files and full files?

<ESMA_QUESTION_570>

AFME Response

AFME agrees with a combination approach but the full list should only be provided annually for a full system refresh (i.e. an override).

<ESMA_QUESTION_570>

Q571: Do you anticipate any difficulties in providing details of financial instruments twice per day?

<ESMA_QUESTION_571>

AFME Response

Venues should have the option to provide their notifications to the NCAs 24 hours a day on an ongoing basis (i.e. notification by notification)

<ESMA_QUESTION_571>

Q572: What other aspects should ESMA consider when determining a suitable solution for the timeframes of the notifications? Please include in your response any foreseen technical limitations.

<ESMA_QUESTION_572>

AFME Response

Please see AFME's response to Question 568.

<ESMA_QUESTION_572>

Q573: Do you agree with the proposed fields? Do trading venues and investment firms have access to the specified reference data elements in order to populate the proposed fields?

<ESMA_QUESTION_573>

AFME Response

AFME’s comments on the fields for debt instruments are provided below.

We also refer to our response to **DP Question 568**

| Field name | AFME comment |
|------------------------------|--|
| Instrument classification | <p>We refer to our response to DP Question 101 – venues should not be responsible for categorising instruments – categorisation should be centralised. We suggest ESMA to propose a clear taxonomy of classification so that venues can populate the fields necessary for the taxonomy so that instruments can be automatically and reliably centrally categorised through logic. ESMA could then have the discretion to recategorise an instrument. We highlight that prospectuses are not machine readable – meaning that the population of the element of the taxonomy will be critical.</p> <p>This should also be provided by second venues</p> |
| Identifier of the instrument | <p>We generally agree with ISIN since an instrument will have an ISIN code if it is admitted to a European venue.</p> <p>We note that there will not be an ISIN for the grey market (i.e. instruments for which there is an application for admission to trading but an ISIN has not been issued). It is critical that ESMA has a mechanism in place to ensure that an instrument does not get reported under multiple identifiers (i.e. many grey market identifiers plus the ISIN later on).</p> <p>As we provided in our response to DP Question 132, recommend that the grey market should not be and is not included within the post trade transparency regime (it is an instrument for which there is an application for admission). Grey market activity takes place prior to admission to trading on trading venues. If grey market is included, the instruments will most often not have an ISIN code, meaning it is highly likely that the instrument may get published under a number of different reference identifiers. We believe that this would undermine the value of the information.</p> |

| | |
|--|---|
| Instrument full name | This fields does not add any extra information and could be populated inconsistently |
| Issuer identifier | We agree with LEI |
| Issuer name | We do not agree – the LEI would provide the information needed |
| Issuer country | We do not agree – the LEI would provide the information needed |
| Issuer type | We do not agree – the LEI would provide the information needed |
| Ultimate issuer name | This should be the “ultimate issuer identifier” and should be the LEI The name is unnecessary |
| Ultimate issuer country code | We do not agree with this field – the LEI contains this information and is sufficient |
| Total number of issued financial instruments | We believe that this is unnecessary since the issued nominal amount and the nominal value per unit is provided |
| Total issued nominal amount | This should be the original issuance We highlight that there is a problem with taps – if ESMA would like to track this, it can only be done so through the issuers This is important information for calibration. |
| Trading venue/systematic internaliser | We do not agree that investment firms should provide reference data – we believe that the appropriate data can be obtained from venues (which will be providing the information for the daily lists for reference data and scope of instruments). The exercise for investment firms is duplicative and unnecessary. Therefore, this should just be the MIC code for venues |
| Date of admittance to trading | We agree with this field This should also be provided by second venues |
| Nominal venue per unit/minimum traded value | We agree with this field |

| | |
|---------------------------------------|---|
| Currency of nominal value | We agree with this field This is important information for calibration |
| Termination (delisting date) | We agree with this field Second venues should also provide this information |
| Maturity date | We agree with this field |
| Issuer's group | We do not believe this is necessary given the LEI is provided |
| LEI of the guarantor of the issuer | We agree with this field |
| Guarantor's group | We do not believe this is necessary given the LEI is provided |
| Fixed rate bonds: level of fixed rate | We recommend that there should first be a field indicating whether the bond is fixed or floating For the field for fixed rate bonds – the coupon should be provided as a % For field for floating rate bonds – the margin in bps should be provided There should be three fields – if there are not – it could introduce confusion. There can be a zero coupon and margin. |
| Identifier of the index | We agree |
| Seniority of the bond | We do not agree – this is not information that can be readily and easily provided. This requires legal interpretation of the prospectus and the results could be highly inconsistent. |
| Issuance price | We agree with this field |
| Issuance price notation | This should be par or percentage or yield |
| Reimbursement price | We agree with this field |
| Currency of reimbursement | We agree with this field |

As set out in our response to **DP Question 568**, the following fields should be provided by both first and second venues:



| Date | ISIN | Create/update/delete | Admitted to trading | Traded on venue | Application to trade | Reference data fields | Delisting |
|------|------|----------------------|---------------------|-----------------|----------------------|-----------------------|-----------|
| | | “” | DATE | DATE | DATE | DATE | DATE |

We also encourage ESMA to identify data fields overlapping with those for transaction reporting and ensure appropriate consistency.

Whilst it is essential that ISINs are used to achieve standardization, we highlight that a significant portion of ISINs are not freely available. Specifically, there are costs and licensing constraints associated with ISINs listed in the US and Canada, which are structured to contain an embedded CUSIP within the ISIN structure that causes CUSIP issuers to demand licenses from companies that redistribute the ISINs within their reporting templates.

<ESMA_QUESTION_573>

Q574: Are you aware of any available industry classification standards you would consider appropriate?

<ESMA_QUESTION_574>

AFME Response

No. However, AFME would welcome further dialogue with ESMA to discuss this.

<ESMA_QUESTION_574>

Q575: For both MiFID and MAR (OTC) derivatives based on indexes are in scope. Therefore it could be helpful to publish a list of relevant indexes. Do you foresee any difficulties in providing reference data for indexes listed on your trading venue? Furthermore, what reference data could you provide on indexes?

<ESMA_QUESTION_575>

TYPE YOUR TEXT HERE

<ESMA_QUESTION_575>

Q576: Do you agree with ESMA’s intention to maintain the current RCA determination rules?

<ESMA_QUESTION_576>

AFME Response

AFME would welcome further dialogue with ESMA to discuss this issue further

<ESMA_QUESTION_576>

Q577: What criteria would you consider appropriate to establish the RCA for instruments that are currently not covered by the RCA rule?

<ESMA_QUESTION_577>

AFME Response



AFME would welcome further dialogue with ESMA to discuss this issue further

<ESMA_QUESTION_577>

<ESMA_QUESTION_1>
TYPE YOUR TEXT HERE
<ESMA_QUESTION_1>

8.3. Obligation to maintain records of orders

Q578: In your view, which option (and, where relevant, methodology) is more appropriate for implementation? Please elaborate.

<ESMA_QUESTION_578>

AFME Response

AFME feels that option 3 would be most preferable. It would enable a standardisation as well as aiding in enhancing harmonisation across the market.

<ESMA_QUESTION_578>

Q579: In your view, what are the data elements that cannot be harmonised? Please elaborate.

<ESMA_QUESTION_579>

AFME Response

No additional comments

<ESMA_QUESTION_579>

Q580: For those elements that would have to be harmonised under Option 2 or under Option 3, do you think industry standards/protocols could be utilised? Please elaborate.

<ESMA_QUESTION_580>

AFME Response

AFME would like to note that these standards are already in place, however a specific format and list would aid in harmonising the market and enhancing efficiency.

<ESMA_QUESTION_580>

Q581: Do you foresee any difficulties with the proposed approach for the use of LEI?

<ESMA_QUESTION_581>

AFME Response

AFME would seek further information whether LEIs which have been inactive for a set period of time could be re-used/re-assigned at a later period in time.

<ESMA_QUESTION_581>

Q582: Do you foresee any difficulties maintaining records of the Client IDs related with the orders submitted by their members/participants? If so, please elaborate.



<ESMA_QUESTION_582>

AFME Response

AFME would like to seek further clarification as to what ESMA envisage by ‘maintaining’ as well as what timeframe is envisaged by use of the word ‘maintaining records’.

<ESMA_QUESTION_582>

Q583: Are there any other solutions you would consider as appropriate to track clients’ order flows through member firms/participants of trading venues and to link orders and transactions coming from the same member firm/participant?

<ESMA_QUESTION_583>

TYPE YOUR TEXT HERE

<ESMA_QUESTION_583>

Q584: Do you believe that this approach allows the order to be uniquely identified If not, please elaborate

<ESMA_QUESTION_584>

AFME Response

AFME would like to seek further clarification as to the envisaged timeframe within which an order is expected to be uniquely identified.

<ESMA_QUESTION_584>

Q585: Do you foresee any difficulties with the implementation of this approach? Please elaborate

<ESMA_QUESTION_585>

AFME Response

No

<ESMA_QUESTION_585>

Q586: Do you foresee any difficulties with the proposed approach? Please elaborate

<ESMA_QUESTION_586>

AFME Response

AFME believe that the envisaged timeframe is very granular and therefore complicated and would make the proposed approach unnecessarily difficult in that respect.

<ESMA_QUESTION_586>

Q587: Do you foresee any difficulties with the proposed approach? Please elaborate.

<ESMA_QUESTION_587>

TYPE YOUR TEXT HERE

<ESMA_QUESTION_587>

Q588: Would the breakdown in the two categories of order types create major issues in terms of mapping of the orders by the Trading Venues and IT developments? Please elaborate

<ESMA_QUESTION_588>



TYPE YOUR TEXT HERE
<ESMA_QUESTION_588>

Q589: Do you foresee any problems with the proposed approach?

<ESMA_QUESTION_589>
TYPE YOUR TEXT HERE
<ESMA_QUESTION_589>

Q590: Are the proposed validity periods relevant and complete? Should additional validity period(s) be provided? Please elaborate.

<ESMA_QUESTION_590>
TYPE YOUR TEXT HERE
<ESMA_QUESTION_590>

Q591: Do you agree that standardised default time stamps regarding the date and time at which the order shall automatically and ultimately be removed from the order book relevantly supplements the validity period flags?

<ESMA_QUESTION_591>
TYPE YOUR TEXT HERE
<ESMA_QUESTION_591>

Q592: Do venues use a priority number to determine execution priority or a combination of priority time stamp and sequence number?

<ESMA_QUESTION_592>

AFME Response

Commonly price and time are used. However this is a very granular microstructure of venues and each venue is different by way of what they provide. Each venue caters to different needs and AFME believes that this should be taken into account.

<ESMA_QUESTION_592>

Q593: Do you foresee any difficulties with the three options described above? Please elaborate.

<ESMA_QUESTION_593>
TYPE YOUR TEXT HERE
<ESMA_QUESTION_593>

Q594: Is the list of specific order instructions provided above relevant? Should this list be supplemented? Please elaborate.

<ESMA_QUESTION_594>
TYPE YOUR TEXT HERE
<ESMA_QUESTION_594>

Q595: Are there any other type of events that should be considered?

<ESMA_QUESTION_595>
TYPE YOUR TEXT HERE
<ESMA_QUESTION_595>

Q596: Do you foresee any difficulties with the proposed approach? Please elaborate.

<ESMA_QUESTION_596>
TYPE YOUR TEXT HERE
<ESMA_QUESTION_596>

Q597: Do you foresee any problems with the proposed approach? Do you consider any other alternative in order to inform about orders placed by market makers and other liquidity providers?

<ESMA_QUESTION_597>
TYPE YOUR TEXT HERE
<ESMA_QUESTION_597>

Q598: Do you foresee any difficulties in generating a transaction ID code that links the order with the executed transaction that stems from that order in the information that has to be kept at the disposal of the CAs? Please elaborate.

<ESMA_QUESTION_598>

AFME Response

AFME believes that this answer would be best provided by venues themselves.

<ESMA_QUESTION_598>

Q599: Do you foresee any difficulties with maintaining this information? Please elaborate.

<ESMA_QUESTION_599>

AFME Response

AFME believes that this answer would be best provided by venues themselves.

<ESMA_QUESTION_599>

8.4. Requirement to maintain records of orders for firms engaging in high-frequency algorithmic trading techniques (Art. 17(7) of MIFID II)²⁰

Q600: Do you foresee any difficulties with the elements of data to be stored proposed in the above paragraph? If so, please elaborate.

<ESMA_QUESTION_600>
TYPE YOUR TEXT HERE
<ESMA_QUESTION_600>

Q601: Do you foresee any difficulties in complying with the proposed timeframe?

<ESMA_QUESTION_601>
TYPE YOUR TEXT HERE
<ESMA_QUESTION_601>

²⁰ Please note that this section has to be read in conjunction with the section on the “Record keeping and co-operation with national competent authorities” in this DP.

8.5. Synchronisation of business clocks

Q602: Would you prefer a synchronisation at a national or at a pan-European level? Please elaborate. If you would prefer synchronisation to a single source, please indicate which would be the reference clock for those purposes.

<ESMA_QUESTION_602>

AFME Response

AFME strongly prefers synchronisation at a pan-European level. AFME believes that any regulation in this area should relate to the maximum divergence to UTC allowed rather than to prescribe the technology that market participants must use to achieve it. Basing synchronisation on a specific protocol or a single source will be significantly challenging or costly for many market participants. PTP is costly to implement and could represent a high technical barrier to entry for many market participants. GPS and a single source also presents some very real practical obstacles. For example, all market participants would have to be granted fair access to collocation roofs. Specifying an implementation to set parameters not technology as part of the regulation, sets the technology landscape at that point in time and does not allow for evolution and improvement. By establishing the expected precision and accuracy (deviation) the regulation would allow better technologies to be adopted as they emerge.

AFME recommends that divergence be expressed by reference to the international stratum levels (ANSI/T1.101-1987) definitions of accuracy since this determines the accuracy of clocks.

These stratum/tiers recognise the practical (operational, technical, implementation, cost) barriers of distribution and synchronisation of time as it fans out from the reference clocks. The highest stratum/tier of accuracy would be applied to events occurring in higher volume execution trading venues (where proximity of GPS synchronised reference clock would be most practical) whereas the lower tiers of accuracy would be appropriate for events occurring further within individual market participants infrastructure where the primary reference clock may have been further disseminated through lower stratum. (I.e. define different minimum stratum for roles such as execution or post-trade processing).

It should be recognised that NTP is the only widely available cross-platform protocol for synchronisation.

To avoid barriers to entry, In terms of synchronising the primary internal reference clock of market participants, this should also be tiered with larger market participants (e.g. with access to dedicated data centres) meeting a higher standard of accuracy (e.g. such as provided by GPS) whereas smaller participants may set the primary clock through more readily available but less accurate means (e.g. NTP over the internet).

<ESMA_QUESTION_602>

Q603: Do you agree with the requirement to synchronise clocks to the microsecond level?

<ESMA_QUESTION_603>

AFME Response

AFME disagrees with a requirement to synchronise all clocks to the microsecond level - should be a tiered/stratum approach as outlined above in our response to question 602. Synchronisation to 1 microsecond would require complex local sourcing in each trading venue site. Keeping within a tolerance of 1 microsecond would be extremely difficult, particularly in any network

propagation of a PTP signal. PTP is not a widely used protocol and while capable of greater accuracy also has dependency on ideal network conditions and potentially costly network reconfiguration; whilst it could be used in a targeted manner for crucial sensitive areas (e.g. trading venue execution) it will not be practical (or useful - see below) to employ widely. It will be technologically impractical to upgrade all software environments to support a finer granularity of time. Even extending timestamp data formats to have sufficient decimal places to hold microseconds would be a massive and costly exercise and in practice no advantage will be gained if the underlying software platform does not provide sufficient granularity of the clock to provide any significant figures past the millisecond level (i.e. always having 000 in the 4th to 6th significant figures). The impact of microsecond timestamps on the IT systems could be significant. Many exchanges do not provide timestamp fields across all trade events, that are large enough to accommodate this level of precision. Many internal systems are accordingly not designed with that level of precision in mind. If the Regulation is to continue with this level of precision then AFME would ask that appropriate consideration be given to the required timeframe. It should be noted that the widely adopted FIX protocol does not support timestamps more precise than 1 millisecond and as such every FIX implementation would need to be revised and updated were it required to carry more precise information.

Moreover, where there is language/OS support, the clock itself has to be read by any running program which is itself a process that will have widely varying latency depending upon whether process is running on physical or virtual server, specific operating system, CPU specification, programming language, load on the server, etc. which could itself add inaccuracies measured in 10s of microseconds to the timestamp read.

It is important therefore to target the granularity requirement to those reportable events which are occurring rapidly enough to require the granularity (e.g. high volume electronic automated executions). For reportable events that originate from manual processes (e.g. voice execution) or on a scheduled date (e.g. lifecycle events) or are generated further back in the trade processing flow, detailed microsecond granularity will be of no value as the accuracy will have been eclipsed entirely by the latency associated with the manual/human processes, inherent batch orientation of the process, or queuing as part of asynchronous transaction processing flow. Even where required (e.g. high volume electronic automated executions) the fact that it can take multiples of microseconds to read the clock means that the microsecond timestamp would still be subject to inaccuracy.

<ESMA_QUESTION_603>

Q604: Which would be the maximum divergence that should be permitted with respect to the reference clock? How often should any divergence be corrected?

<ESMA_QUESTION_604>

AFME Response

Taking into account the comments to the responses to questions 602 and 603 above, AFME believes that a maximum divergence of 1 millisecond should be permitted with respect to the reference clock. AFME regards that the setting of a maximum divergence dictates continuous and automatic monitoring and correction of that divergence, however if periodic checks are to be stipulated then AFME concurs that checks should be made outside of market hours. A parameter to re-check divergence up to a maximum of 30 minutes is right although in practice protocols will go into a cycle of more frequent checking when a divergence is recognised. As a result of the fact that unsynchronised clocks can drift by more than a second a day, making out of hours checks at odds with the accuracy proposals, AFME believe that all market participants should



expect to run continuous synchronisation of their clocks and should not be permitted to have unsynchronised clocks.

For smaller participants unable to leverage GPS for setting the reference clock, falling back to NTP, the protocol will check and correct recognised divergences but what cannot practically be measured or controlled is the fundamental divergence introduced by NTP dependence on ideal network conditions for accuracy.

AFME would welcome further discussions on this topic with ESMA.

<ESMA_QUESTION_604>

9. Post-trading issues

9.1. Obligation to clear derivatives traded on regulated markets and timing of acceptance for clearing (STP)

Q605: What are your views generally on (1) the systems, procedures, arrangements supporting the flow of information to the CCP, (2) the operational process that should be in place to perform the transfer of margins, (3) the relevant parties involved these processes and the time required for each of the steps?

<ESMA_QUESTION_605>

TYPE YOUR TEXT HERE

<ESMA_QUESTION_605>

Q606: In particular, who are currently responsible, in the ETD and OTC context, for obtaining the information required for clearing and for submitting the transaction to a CCP for clearing? Do you consider that anything should be changed in this respect? What are the current timeframes, in the ETD and OTC context, between the conclusion of the contract and the exchange of information required for clearing on one hand and on the other hand between the exchange of information and the submission of the transaction to the CCP?

<ESMA_QUESTION_606>

TYPE YOUR TEXT HERE

<ESMA_QUESTION_606>

Q607: What are your views on the balance of these risks against the benefits of STP for the derivatives market and on the manner to mitigate such risks at the different levels of the clearing chain?

<ESMA_QUESTION_607>

TYPE YOUR TEXT HERE

<ESMA_QUESTION_607>

Q608: When does the CM assume the responsibility of the transactions? At the time when the CCP accepts the transaction or at a different moment in time?

<ESMA_QUESTION_608>

TYPE YOUR TEXT HERE

<ESMA_QUESTION_608>

Q609: What are your views on how practicable it would be for CM to validate the transaction before their submission to the CCP? What would the CM require for this purpose and the timeframe required? How would this validation process fit with STP?

<ESMA_QUESTION_609>

TYPE YOUR TEXT HERE

<ESMA_QUESTION_609>

Q610: What are your views on the manner to determine the timeframe for (1) the exchange of information required for clearing, (2) the submission of a transaction to the CCP, and the constraints and requirements to consider for parties involved in both the ETD and OTC contexts?

<ESMA_QUESTION_610>
TYPE YOUR TEXT HERE
<ESMA_QUESTION_610>

Q611: What are your views on the systems, procedures, arrangements and timeframe for (1) the submission of a transaction to the CCP and (2) the acceptance or rejection of a transaction by the CCP in view of the operational process required for a strong product validation in the context of ETD and OTC? How should it compare with the current process and timeframe? Does the current practice envisage a product validation?

<ESMA_QUESTION_611>
TYPE YOUR TEXT HERE
<ESMA_QUESTION_611>

Q612: What should be the degree of flexibility for CM, its timeframe, and the characteristics of the systems, procedures and arrangements required to supporting that flexibility? How should it compare to the current practices and timeframe?

<ESMA_QUESTION_612>
TYPE YOUR TEXT HERE
<ESMA_QUESTION_612>

Q613: What are your views on the treatment of rejected transactions for transactions subject to the clearing requirement and those cleared on a voluntary basis? Do you agree that the framework should be set in advance?

<ESMA_QUESTION_613>
TYPE YOUR TEXT HERE
<ESMA_QUESTION_613>

9.2. Indirect Clearing Arrangements

Q614: Is there any reason for ESMA to adopt a different approach (1) from the one under EMIR, (2) for OTC and ETD? If so, please explain your reasons.

<ESMA_QUESTION_614>
TYPE YOUR TEXT HERE
<ESMA_QUESTION_614>

Q615: In your view, how should it compare with current practice?

<ESMA_QUESTION_615>
TYPE YOUR TEXT HERE
<ESMA_QUESTION_615>